

IN-VEHICLE SERVICING

FLUID PAN, GASKET AND FILTER

Material

Item	Specification
MERCON® SP Automatic Transmission Fluid XT-6-QSP (US); CXT-6-LSP12 (Canada)	MERCON® SP

REMOVAL

CAUTION: The use of any other transmission fluid than specified, can result in the transmission failing to operate in a normal manner or transmission failure.

1. With the vehicle in NEUTRAL, position it on a hoist. For additional information, refer to **JACKING AND LIFTING**.
2. Remove the fill plug fluid level indicator assembly located on the passenger side front portion of the transmission case. Removal of the plug will relieve any vacuum that might have built up in the transmission. This will allow the fluid pan to be easily removed when the bolts are removed.

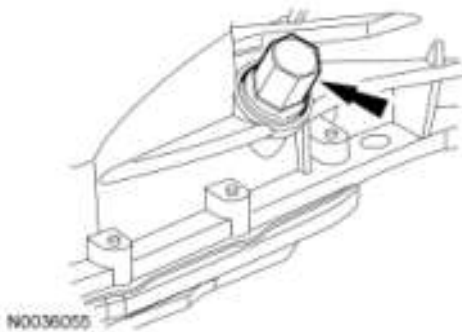

Fig. 37: Locating Fluid Fill Plug
Courtesy of FORD MOTOR CO.

3. Remove the transmission fluid pan and allow the fluid to drain.

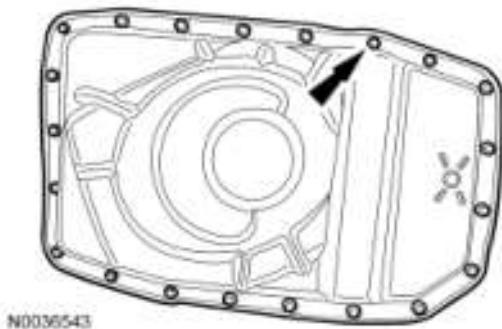
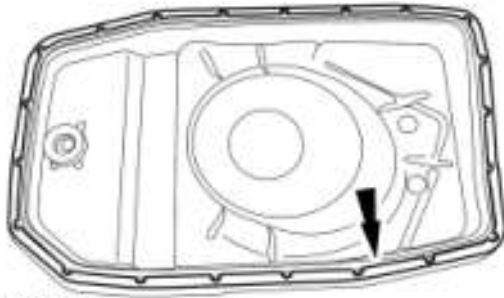

Fig. 38: Locating Transmission Fluid Pan Bolts
Courtesy of FORD MOTOR CO.

4. Remove the fluid pan gasket.



N0036570

Fig. 39: Locating Transmission Fluid Pan Gasket
Courtesy of FORD MOTOR CO.

5. Remove and discard the transmission fluid filter.

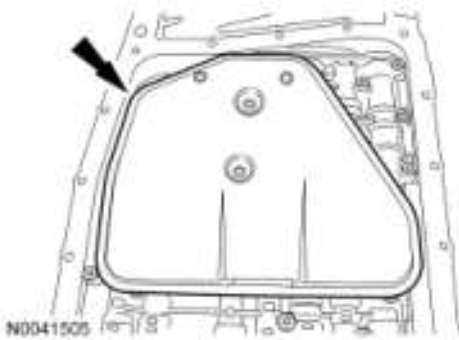

N0041505

Fig. 40: Locating Transmission Fluid Filter
Courtesy of FORD MOTOR CO.

6. Clean and inspect the transmission fluid pan and magnet.

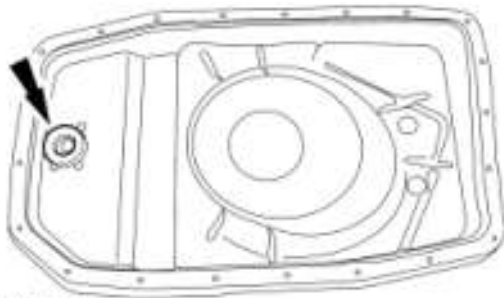

N0041504

Fig. 41: Locating Transmission Fluid Pan And Magnet
Courtesy of FORD MOTOR CO.

INSTALLATION

NOTE: If the transmission is being repaired for a contamination-related failure, install a new transmission fluid filter and seal assembly. The fluid filter may be reused if no excessive contamination is indicated.

1. Inspect the transmission case for the transmission fluid filter seal. If the seal is in the case, carefully remove the seal without scratching the case.

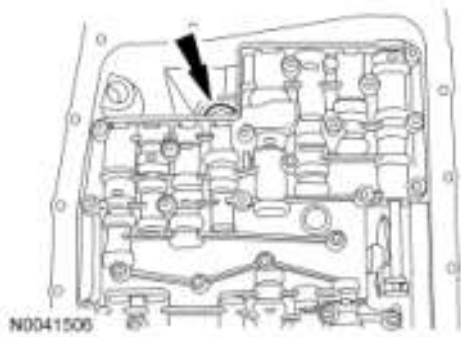

Fig. 42: Locating Transmission Fluid Filter Seal
 Courtesy of FORD MOTOR CO.

2. Make sure that the seal is on the transmission fluid filter and lubricate the seal with clean automatic transmission fluid.

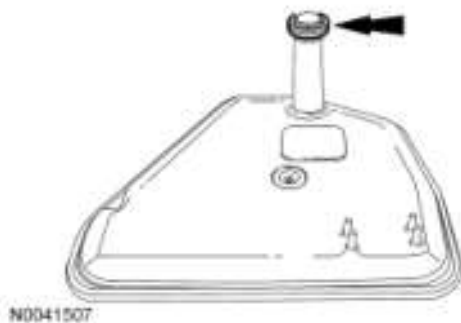

Fig. 43: Locating Seal On Transmission Fluid Filter
 Courtesy of FORD MOTOR CO.

NOTE: The fluid filter may be reused if no excessive contamination is indicated.

3. Install a new transmission fluid filter.

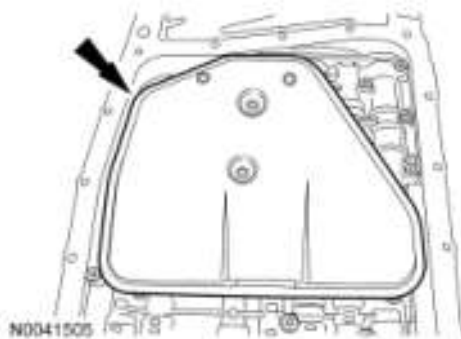
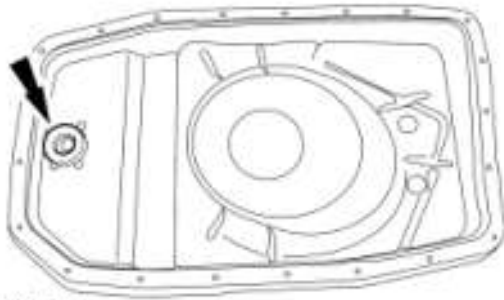

Fig. 44: Locating Transmission Fluid Filter
 Courtesy of FORD MOTOR CO.

4. Position the magnet in the transmission fluid pan.



N0041504

Fig. 45: Locating Transmission Fluid Pan And Magnet
Courtesy of FORD MOTOR CO.

NOTE: The fluid pan gasket can be reused if not damaged.

5. Install a new transmission fluid pan gasket if required.

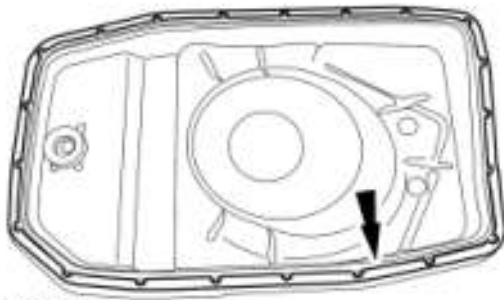

N0036570

Fig. 46: Locating Transmission Fluid Pan Gasket
Courtesy of FORD MOTOR CO.

6. Install the fluid pan and tighten the bolts in a crisscross pattern.
 - Tighten to 14 Nm (10 lb-ft).

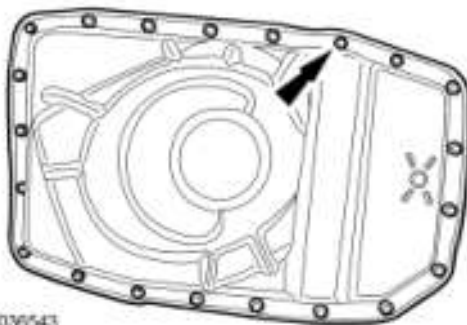

N0036543

Fig. 47: Locating Transmission Fluid Pan Bolts
Courtesy of FORD MOTOR CO.

7. Using the refill procedure, fill the transmission with clean automatic transmission fluid. For additional information, refer to **Transmission Fluid Drain and Refill**.

REMOVAL

NOTE: If a new or the existing mechatronic assembly is installed, the transmission control module (TCM) will need to be reflashed to the latest level calibration available.

1. With the vehicle in NEUTRAL, position it on a hoist. For additional information, refer to **JACKING AND LIFTING**.

CAUTION: Do not pull on the wire harness to disconnect the connector or damage to the connector will occur.

2. Disconnect the main transmission electrical harness by twisting the outer shell and pulling back on the connector.

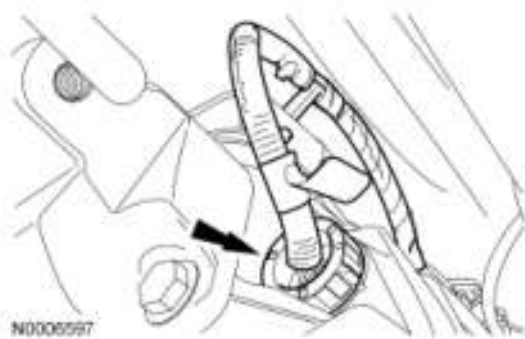

Fig. 48: Locating Main Transmission Electrical Harness Connector
Courtesy of FORD MOTOR CO.

3. Remove the fill plug fluid level indicator assembly located on the passenger side front portion of the transmission case. Removal of the plug will relieve any vacuum that might have built up in the transmission. This will allow the fluid pan to be easily removed when the bolts are removed.

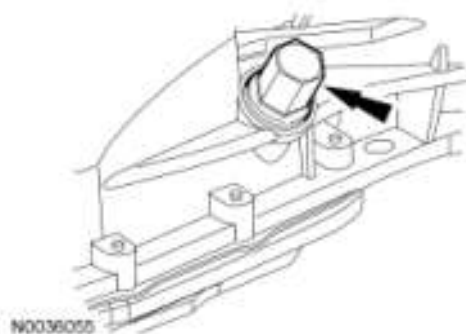

Fig. 49: Locating Fluid Fill Plug
Courtesy of FORD MOTOR CO.

4. Remove the transmission fluid pan and allow the fluid to drain.

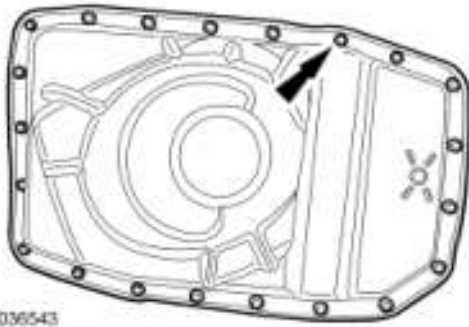

Fig. 50: Locating Transmission Fluid Pan Bolts
Courtesy of FORD MOTOR CO.

5. Remove the fluid pan gasket.

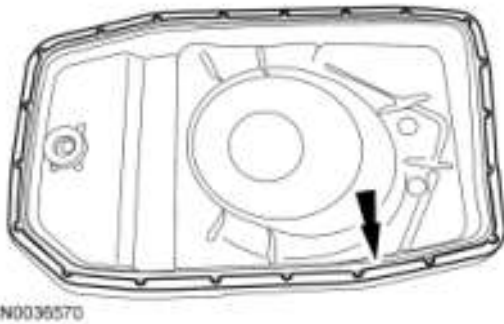

Fig. 51: Locating Transmission Fluid Pan Gasket
Courtesy of FORD MOTOR CO.

6. Remove and discard the transmission fluid filter.

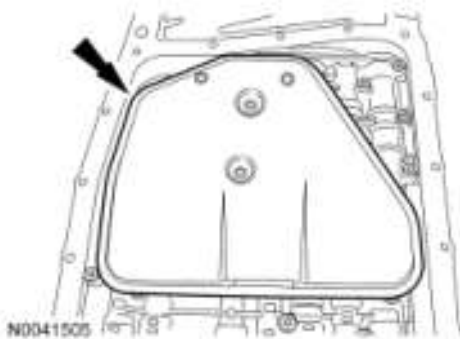

Fig. 52: Locating Transmission Fluid Filter
Courtesy of FORD MOTOR CO.

7. Pull the release tab and pull down on the bulkhead connector retainer.

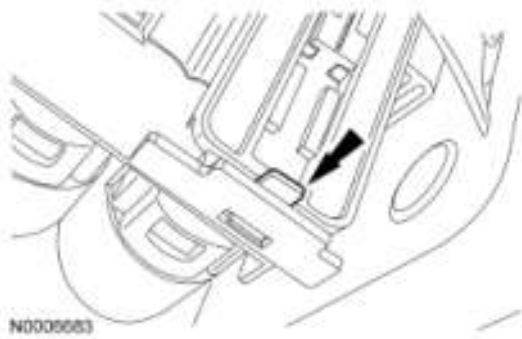

Fig. 53: Locating Bulkhead Connector Retainer Tab
Courtesy of FORD MOTOR CO.

CAUTION: Do not touch the electrical connector pins or the exposed solenoid tabs on the TCM. Electrostatic discharge may occur and may cause damage to the mechatronic unit.

8. With the release tab down, pull the outer shell of the bulkhead electrical connector out of the TCM.



Fig. 54: Locating Outer Shell Of Bulkhead Electrical Connector
Courtesy of FORD MOTOR CO.

CAUTION: Do not touch the electrical connector pins or the exposed solenoid tabs on the TCM. Electrostatic discharge may occur and may cause damage to the mechatronic unit.

9. Pull the bulkhead electrical connector out of the transmission.



Fig. 55: Locating Outer Shell Of Bulkhead Electrical Connector
Courtesy of FORD MOTOR CO.

NOTE: During removal of the mechatronic, the thermal bypass valve, pump adapter seal and one or more center support seals may become dislodged. Save these components for reuse during assembly.

10. Remove the 11 bolts from the mechatronic assembly and remove the mechatronic assembly.

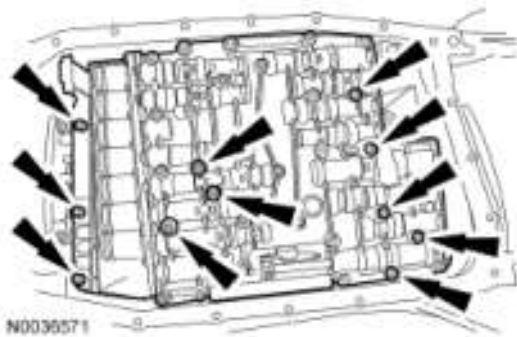

Fig. 56: Locating Mechatronic Assembly Bolts
Courtesy of FORD MOTOR CO.

INSTALLATION

NOTE: Before reinstalling the mechatronic assembly into the transmission case, verify presence and correct orientation of the thermal bypass valve, pump adapter seal and center support seals. Also note that one or more of the center support seals may have remained in the mechatronic assembly during removal and should be installed into the transmission case at this time.

1. Verify the 4 rubber feed tubes for the center support are in place.
 1. Black feed tube.
 2. Green feed tube.
 3. Blue feed tube.

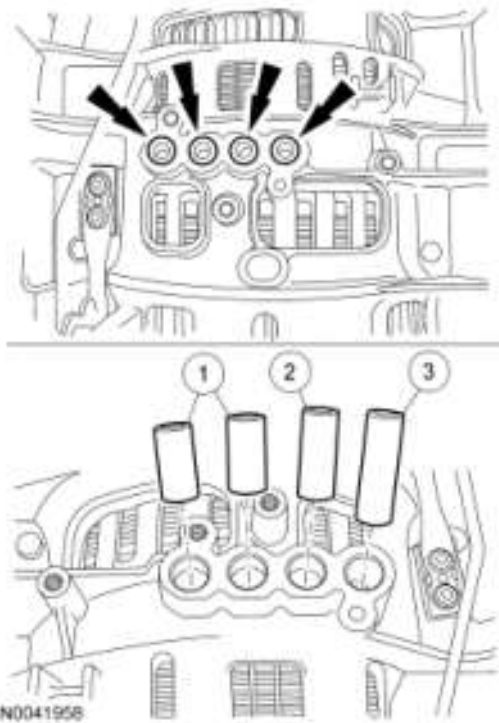

Fig. 57: Locating Rubber Feed Tubes
 Courtesy of FORD MOTOR CO.

2. Verify the rubber adapter is in place.



Fig. 58: Locating Rubber Adapter
 Courtesy of FORD MOTOR CO.

3. Verify the thermal bypass valve is in the case.

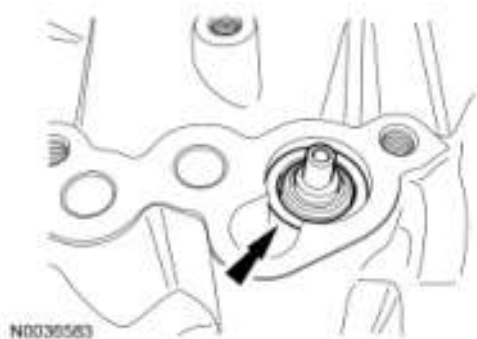

Fig. 59: Locating Thermal Bypass Valve

Courtesy of FORD MOTOR CO.

4. Position the mechatronic assembly in place and loosely install the 11 bolts.
 1. Align the manual valve and control lever linkage.

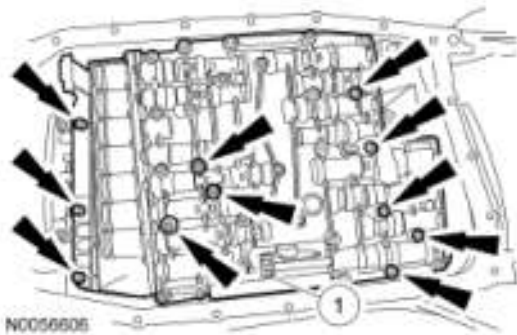

Fig. 60: Locating Mechatronic Assembly Bolts
Courtesy of FORD MOTOR CO.

5. Tighten the mechatronic bolts in the sequence shown.
 - Tighten to 6 Nm (53 lb-in).

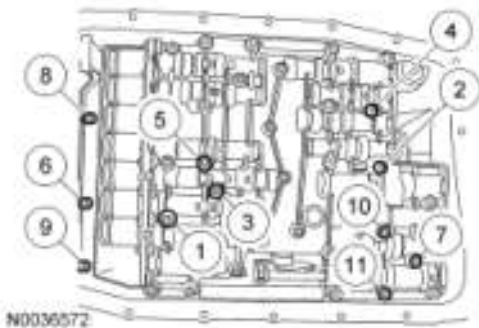

Fig. 61: Tightening Mechatronic Bolts In Sequence
Courtesy of FORD MOTOR CO.

CAUTION: Do not touch the electrical connector pins or the exposed solenoid tabs on the TCM. Electrostatic discharge may occur and may cause damage to the mechatronic unit.

6. With the release tab down and unlocked, push the outer shell of the bulkhead electrical connector into the transmission. Make sure that the bulkhead connector is fully seated into the TCM.



Fig. 62: Locating Outer Shell Of Bulkhead Electrical Connector
Courtesy of FORD MOTOR CO.

7. Press up on the tab and lock the outer shell of the bulkhead electrical connector in place. Make sure that the locking tab is securely locked.

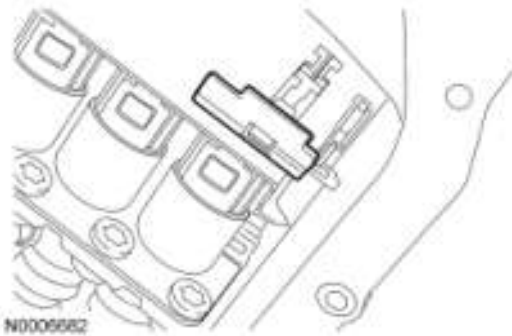

Fig. 63: Pressing Up On Tab & Locking Outer Shell Of Bulkhead Electrical Connector In Place
Courtesy of FORD MOTOR CO.

8. Install a new transmission fluid filter.

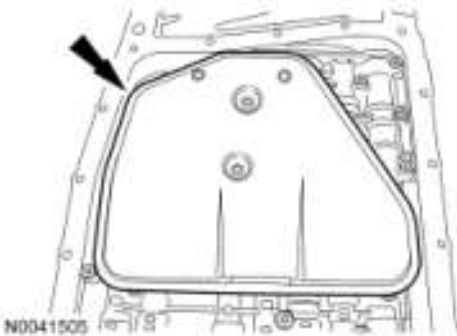

Fig. 64: Locating Transmission Fluid Filter
Courtesy of FORD MOTOR CO.

NOTE: The fluid pan gasket can be reused if not damaged.

9. Install the transmission fluid pan gasket if required.

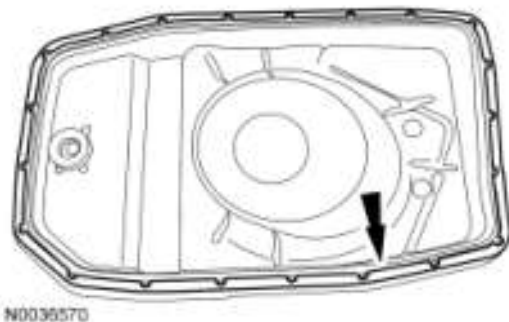

Fig. 65: Locating Transmission Fluid Pan Gasket
Courtesy of FORD MOTOR CO.

10. Install the fluid pan and tighten the bolts in a crisscross pattern.
 - Tighten to 14 Nm (10 lb-ft).

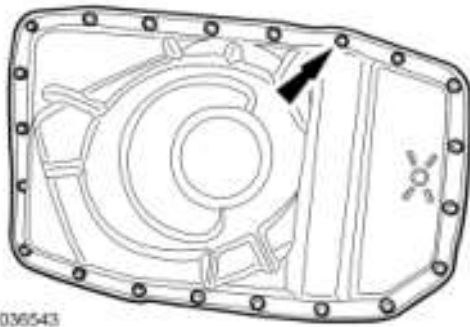

Fig. 66: Locating Transmission Fluid Pan Bolts
 Courtesy of FORD MOTOR CO.

11. Connect the main transmission electrical harness by pushing it in and twisting the outer shell to lock it in place.





Fig. 67: Locating Main Transmission Electrical Harness Connector
 Courtesy of FORD MOTOR CO.

12. Using the refill procedure, fill the transmission with clean automatic transmission fluid. For additional information, refer to **Transmission Fluid Drain and Refill**.
13. If a new or the existing mechatronic assembly is installed, the TCM will need to be reflashed to the latest level calibration available.

OUTPUT SHAFT SEAL

Special Tools

Illustration	Tool Name	Tool Number
 ST2698-A	Installer, Transmission Extension Housing Fluid Seal	307-560
	Installer, Fluid Pump Seal	307-556

 ST2887-A		
 ST2381-A	Remover, Input Shaft Oil Seal	308-375
 ST1187-A	Slide Hammer	100-001 (T50T-100-A)

Material

Item	Specification
MERCON® SP Automatic Transmission Fluid XT-6-QSP (US); CXT-6-LSP12 (Canada)	MERCON® SP

NOTE: Rear wheel drive (RWD) shown, four wheel drive (4WD) similar.

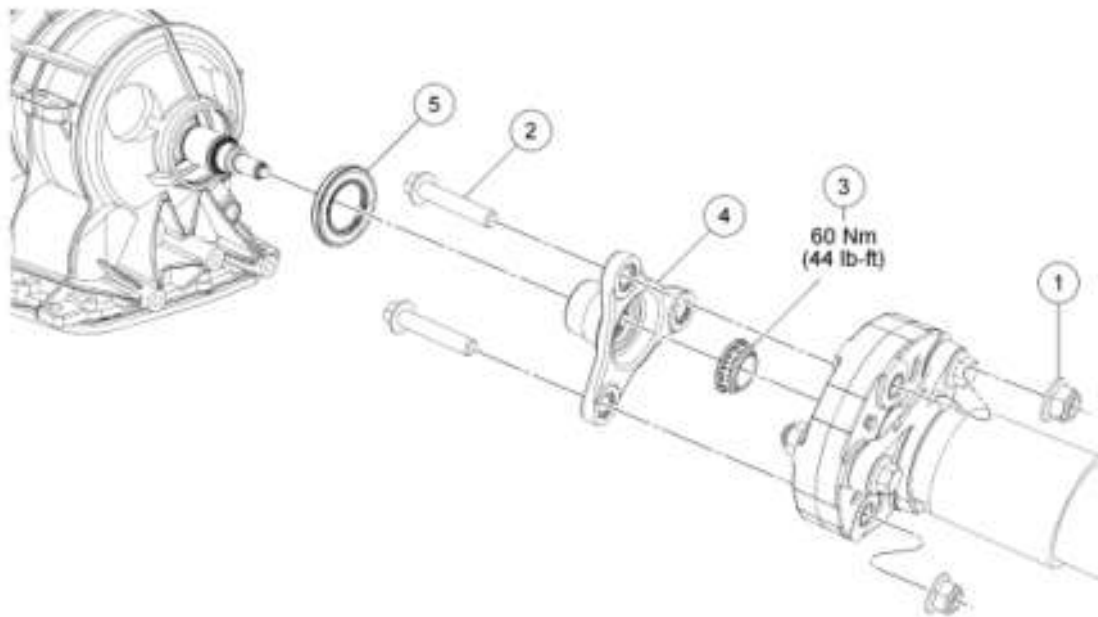

N0065762

Fig. 68: Exploded View Of Output Shaft Seal With Torque Specifications
Courtesy of FORD MOTOR CO.

Item	Part Number	Description
------	-------------	-------------

1	-	Rear driveshaft bolt (4 required)
2	-	Rear driveshaft
3	7K440	Output shaft flange nut
4	7A021	Output shaft flange
5	7052	Output shaft seal

REMOVAL

All vehicles

1. With the vehicle in NEUTRAL, position it on a hoist. For additional information, refer to **JACKING AND LIFTING** .

Rear wheel drive (RWD) vehicles

2. Remove the rear driveshaft. For additional information, refer to **DRIVESHAFT** .

NOTE: The output shaft flange nut has been staked to prevent it from coming loose. Prior to removing the output shaft flange nut, remove the stake to prevent damage to the output shaft.

3. Remove and discard the output shaft flange nut.

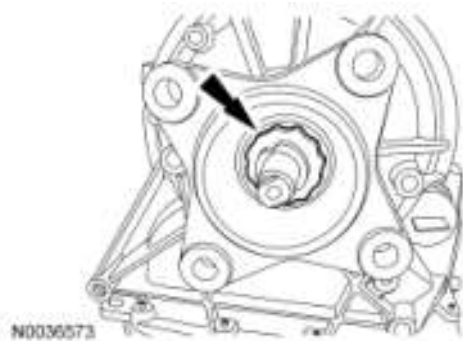

Fig. 69: Locating Output Shaft Flange Nut
Courtesy of FORD MOTOR CO.

4. Remove the output shaft flange.

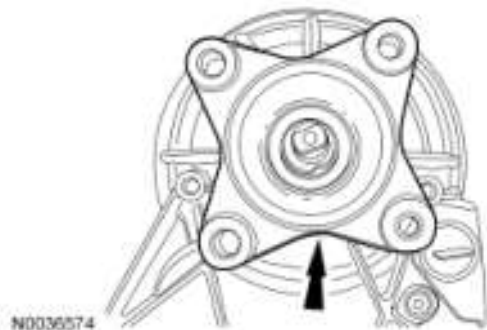

Fig. 70: Locating Output Shaft Flange
Courtesy of FORD MOTOR CO.

- Using the special tools, remove the output shaft seal.

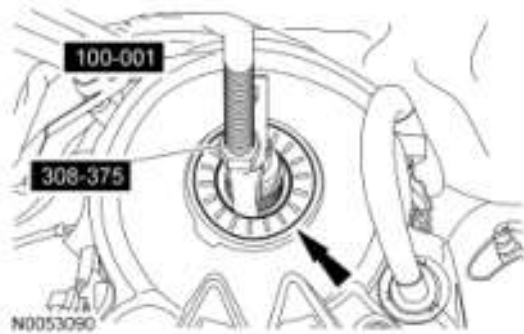

Fig. 71: Removing Output Shaft Seal
Courtesy of FORD MOTOR CO.

Four wheel drive (4WD) vehicles

- Remove the transfer case. For additional information, refer to **TRANSFER CASE** .
- Using the special tools, remove the output shaft seal.

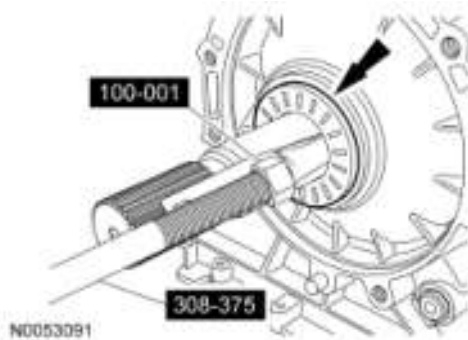

Fig. 72: Removing Output Shaft Seal Using Special Tools (100-001, 308-375)
Courtesy of FORD MOTOR CO.

INSTALLATION

RWD vehicles

- Position a new output shaft seal.

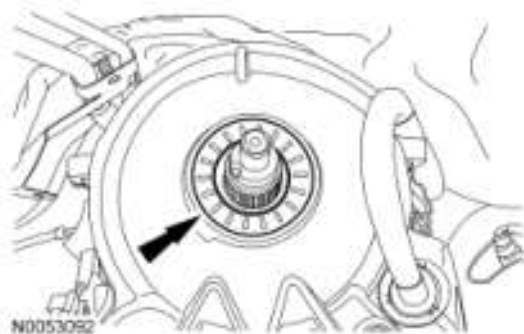

Fig. 73: Positioning Output Shaft Seal
Courtesy of FORD MOTOR CO.

- Using the special tool, install the output shaft seal.

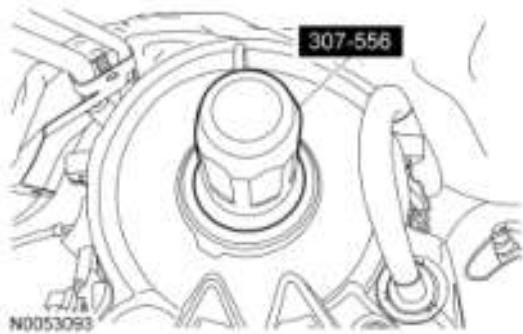

Fig. 74: Installing Output Shaft Seal Using Special Tool (307-556)
Courtesy of FORD MOTOR CO.

- Install the output shaft flange.

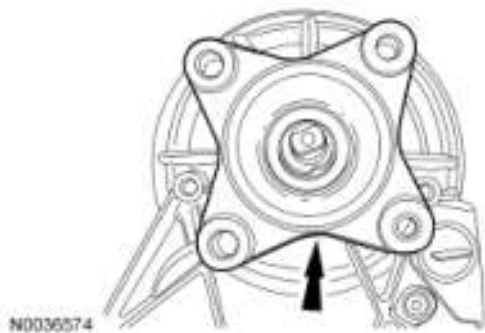

Fig. 75: Locating Output Shaft Flange
Courtesy of FORD MOTOR CO.

- Install a new output shaft flange nut.
 - Tighten to 60 Nm (44 lb-ft).
 - After installing the new nut, it must be staked at the slots to prevent it from coming loose.

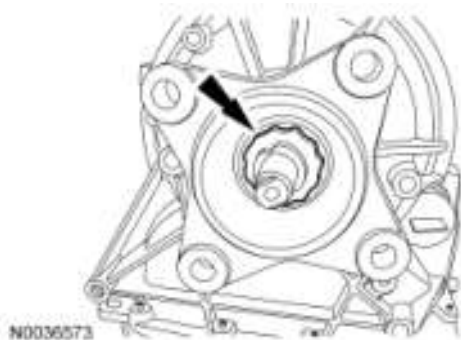

Fig. 76: Locating Output Shaft Flange Nut
Courtesy of FORD MOTOR CO.

- Install the rear driveshaft. For additional information, refer to **DRIVESHAFT** .

4WD vehicles

- Position the output shaft seal.

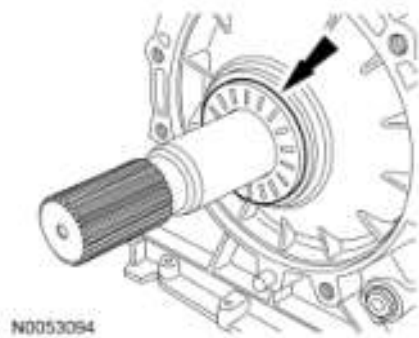

Fig. 77: Locating Output Shaft Seal
Courtesy of FORD MOTOR CO.

- Using the special tool, install a new output shaft seal.

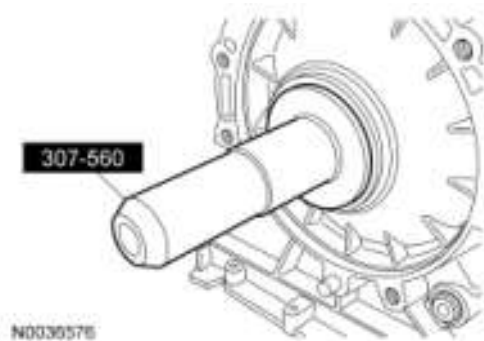

Fig. 78: Installing Output Shaft Seal Using Special Tool (307-560)
Courtesy of FORD MOTOR CO.

- Install the transfer case. For additional information, refer to [TRANSFER CASE](#) .

All vehicles

- Fill and check the transmission fluid. For additional information, refer to [Transmission Fluid Level Check](#).

MANUAL CONTROL LEVER SHAFT AND SEAL

Special Tools

Illustration	Tool Name	Tool Number
	Installer, Shift Shaft Fluid Seal	307-559

Material

Item	Specification

REMOVAL

1. With the vehicle in NEUTRAL, position it on a hoist. For additional information, refer to **JACKING AND LIFTING**.
2. Disconnect the selector lever cable end.

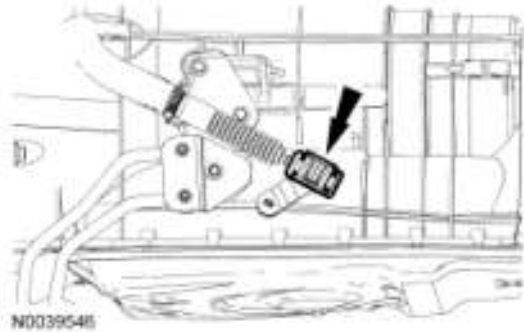

Fig. 79: Locating Selector Lever Cable From Manual Control Lever
Courtesy of FORD MOTOR CO.

3. Remove the fill plug fluid level indicator assembly located on the passenger side front portion of the transmission case. Removal of the plug will relieve any vacuum that might have built up in the transmission. This will allow the fluid pan to be easily removed when the bolts are removed.

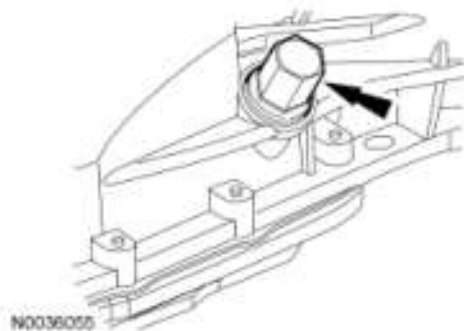

Fig. 80: Locating Fluid Fill Plug
Courtesy of FORD MOTOR CO.

4. Remove the transmission fluid pan and allow the fluid to drain.

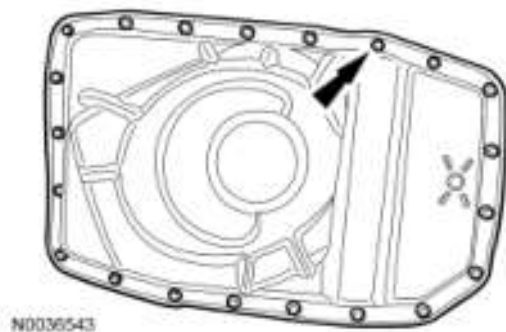

Fig. 81: Locating Transmission Fluid Pan Bolts
Courtesy of FORD MOTOR CO.

5. Remove and discard the transmission fluid filter.

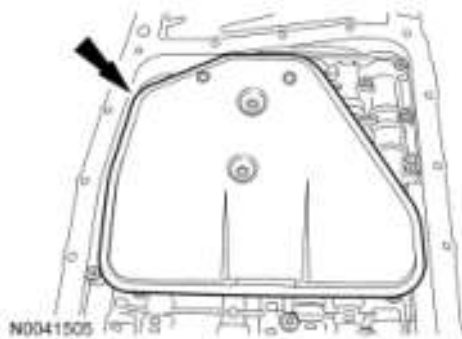

Fig. 82: Locating Transmission Fluid Filter
Courtesy of FORD MOTOR CO.

6. Remove the fluid pan gasket.

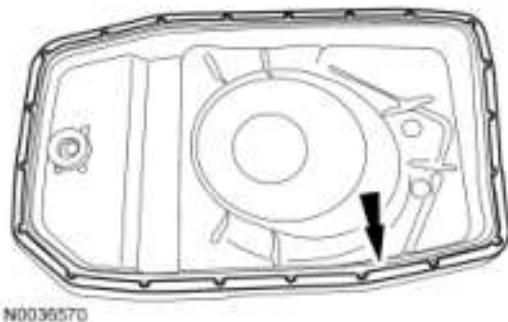

Fig. 83: Locating Transmission Fluid Pan Gasket
Courtesy of FORD MOTOR CO.

CAUTION: Do not pull on the wire harness to disconnect the connector or damage to the connector will occur.

7. Disconnect the main transmission electrical harness by twisting the outer shell and pulling back on the connector.

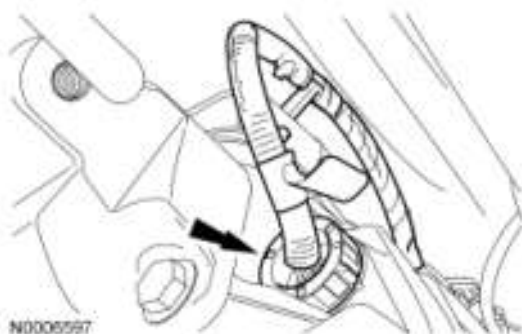

Fig. 84: Locating Main Transmission Electrical Harness Connector
Courtesy of FORD MOTOR CO.

8. Pull the release tab and pull down on the bulkhead connector retainer.

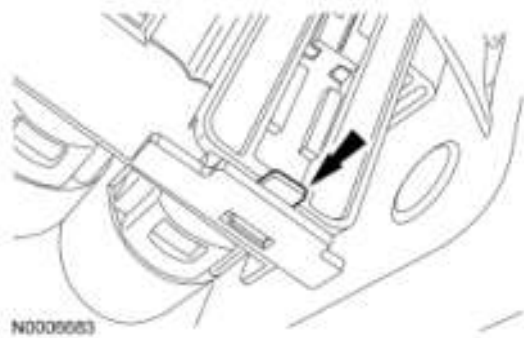

Fig. 85: Locating Bulkhead Connector Retainer Tab
Courtesy of FORD MOTOR CO.

CAUTION: Do not touch the electrical connector pins or the exposed solenoid tabs on the transmission control module (TCM). Electrostatic discharge may occur and may cause damage to the mechatronic unit.

9. With the release tab down, pull the outer shell of the bulkhead electrical connector out of the transmission control module (TCM).



Fig. 86: Locating Outer Shell Of Bulkhead Electrical Connector
Courtesy of FORD MOTOR CO.

CAUTION: Do not touch the electrical connector pins or the exposed solenoid tabs on the TCM. Electrostatic discharge may occur and may cause damage to the mechatronic unit.

10. Pull the bulkhead electrical connector out of the transmission.



Fig. 87: Locating Outer Shell Of Bulkhead Electrical Connector
 Courtesy of FORD MOTOR CO.

NOTE: During removal of the mechatronic, the thermal bypass valve, pump adapter seal and one or more center support seals may become dislodged. Save these components for reuse during assembly.

11. Remove the 11 bolts from the mechatronic assembly and remove the mechatronic assembly.

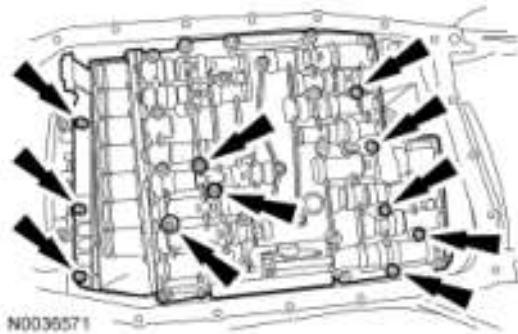

Fig. 88: Locating Mechatronic Assembly Bolts
 Courtesy of FORD MOTOR CO.

12. Remove the park pawl abutment.

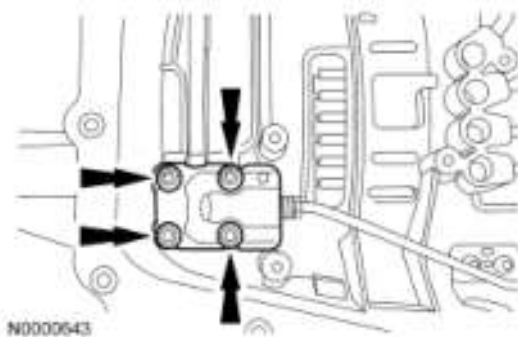

Fig. 89: Locating Park Pawl Abutment
 Courtesy of FORD MOTOR CO.

13. Remove the manual control lever.
 1. Remove the roll pin.
 2. Slide the manual control lever shaft out of the case.

3. Hold the spacer to keep it from falling out of the case.
4. Remove the manual valve inner lever and the park rod as an assembly.

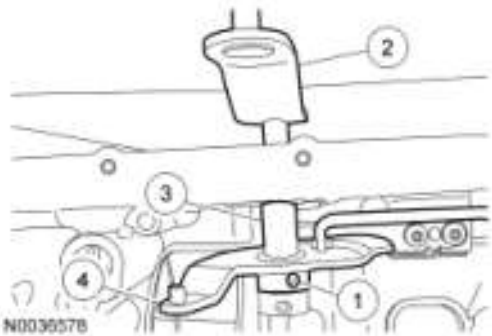

Fig. 90: Identifying Roll Pin, Manual Control Lever, Spacer, Manual Valve Inner Lever And Park Rod
 Courtesy of FORD MOTOR CO.

14. Remove and discard the manual control lever seal.

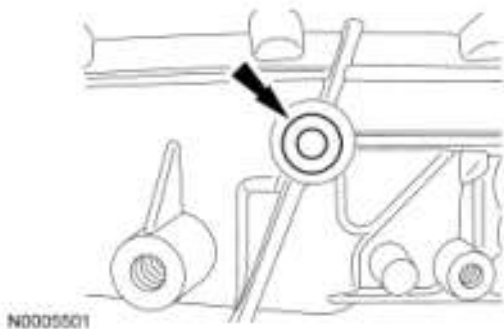

Fig. 91: Locating Manual Control Lever Seal
 Courtesy of FORD MOTOR CO.

INSTALLATION

1. Position a new manual control lever seal in place.

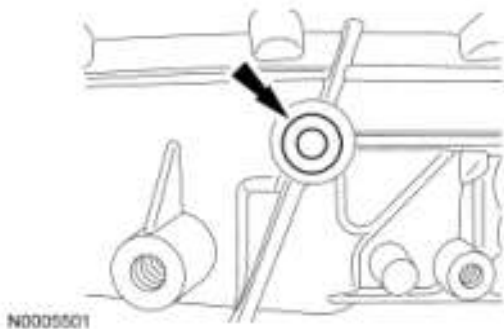

Fig. 92: Locating Manual Control Lever Seal
 Courtesy of FORD MOTOR CO.

2. Using the special tool, install a new manual control lever shaft seal.

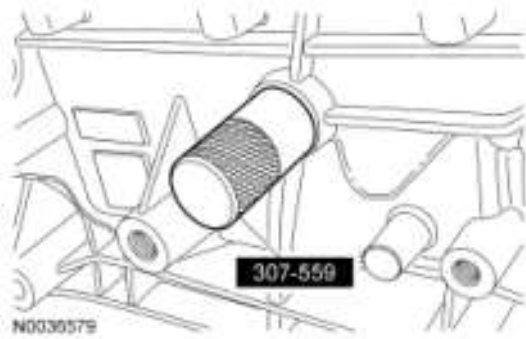

Fig. 93: Installing Manual Control Lever Shaft Seal Using Special Tool (307-559)
Courtesy of FORD MOTOR CO.

3. Install the manual lever in the case.
 1. Slide the manual lever in the case.
 2. Position the spacer in place while sliding the manual lever into the spacer.
 3. Position the manual valve inner lever while sliding the manual lever and lining up the roll pin hole.
 4. Install the roll pin.

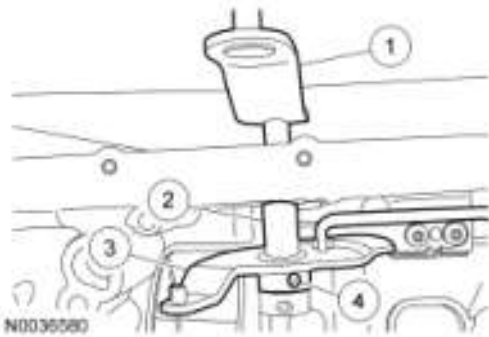

Fig. 94: Identifying Manual Valve Lever
Courtesy of FORD MOTOR CO.

4. Position the park rod in place. Push down on the park pawl and position the park rod in place.
5. While holding the park rod down, install the park pawl abutment.
 - Tighten to 10 Nm (89 lb-in).

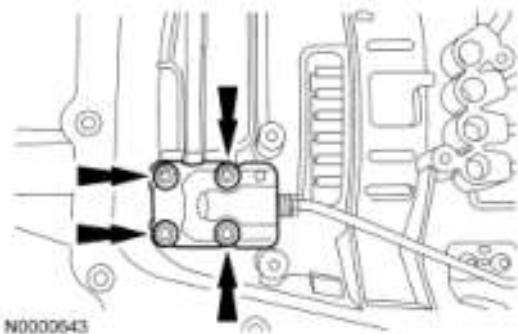

Fig. 95: Locating Park Pawl Abutment
Courtesy of FORD MOTOR CO.

NOTE: Before installing the mechatronic assembly into the transmission case, verify presence and correct orientation of the thermal bypass valve, pump adapter seal and center support seals. Also note that one or more of the center support seals may have remained in the mechatronic assembly during removal and should be installed into the transmission case at this time.

6. Verify the 4 rubber feed tubes for the center support are in place.
 1. Black feed tube.
 2. Green feed tube.
 3. Blue feed tube.

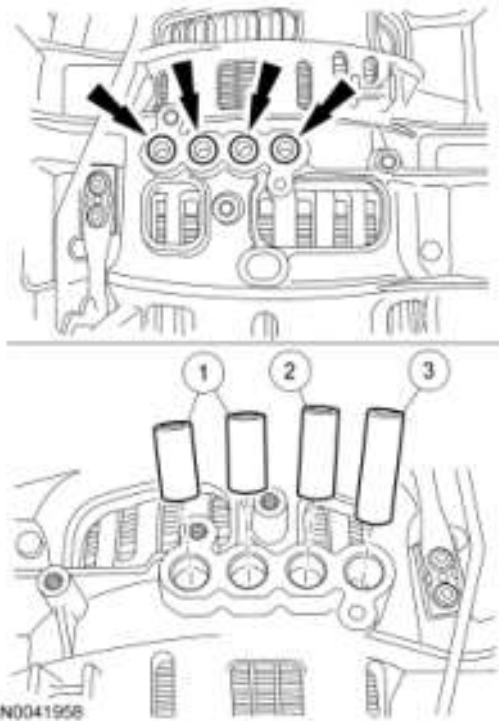

Fig. 96: Locating Rubber Feed Tubes
Courtesy of FORD MOTOR CO.

7. Verify the rubber adapter is in place.



Fig. 97: Locating Rubber Adapter
Courtesy of FORD MOTOR CO.

8. Verify the thermal bypass valve is in the case.

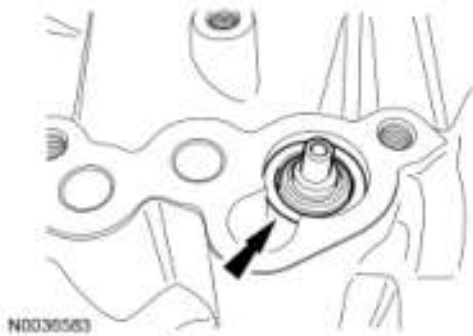

Fig. 98: Locating Thermal Bypass Valve
Courtesy of FORD MOTOR CO.

CAUTION: Do not touch the electrical connector pins or the exposed solenoid tabs on the TCM. Electrostatic discharge may occur and may cause damage to the mechatronic unit.

9. Position the mechatronic assembly in place and loosely install the 11 bolts.
1. Align the manual valve and control lever linkage.

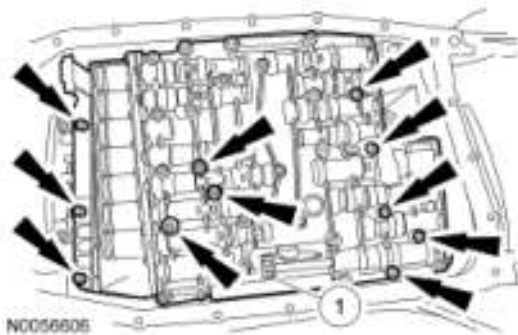

Fig. 99: Locating Mechatronic Assembly Bolts
Courtesy of FORD MOTOR CO.

10. Tighten the mechatronic bolts in the sequence shown.
- Tighten to 6 Nm (53 lb-in).

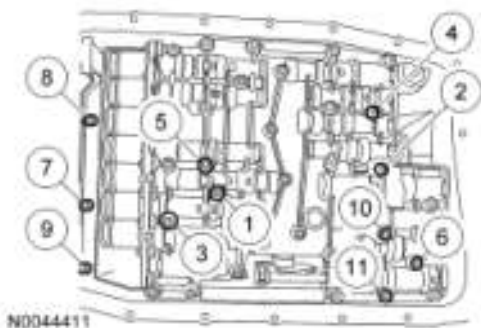

Fig. 100: Tightening Mechatronic Bolts In Sequence
Courtesy of FORD MOTOR CO.

CAUTION: Do not touch the electrical connector pins. Electrostatic discharge may occur and will cause damage to the mechatronic unit.

11. With the release tab down and unlocked, push the outer shell of the bulkhead electrical connector into the transmission. Make sure that the bulkhead connector is fully seated into the TCM.



Fig. 101: Locating Outer Shell Of Bulkhead Electrical Connector
Courtesy of FORD MOTOR CO.

12. Press up on the tab and lock the outer shell of the bulkhead electrical connector in place.

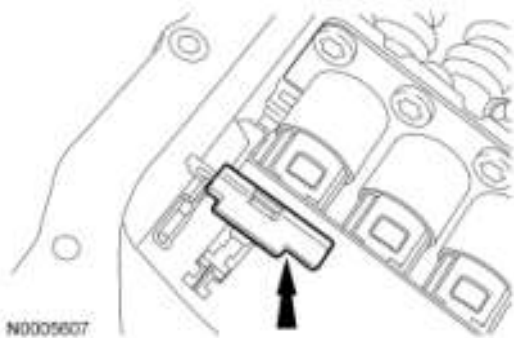

Fig. 102: Locating Outer Shell Of Bulkhead Electrical Connector And Tab
Courtesy of FORD MOTOR CO.

13. Install a new transmission fluid filter.

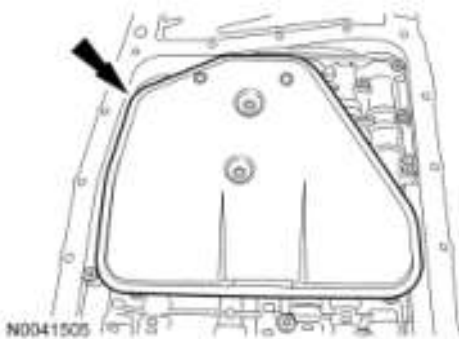

Fig. 103: Locating Transmission Fluid Filter
Courtesy of FORD MOTOR CO.

NOTE: The fluid pan gasket can be reused if not damaged.

14. Install the transmission fluid pan gasket if necessary.

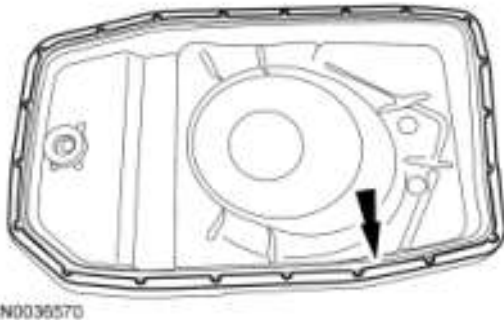

Fig. 104: Locating Transmission Fluid Pan Gasket
Courtesy of FORD MOTOR CO.

15. Install the fluid pan and tighten the bolts in a crisscross pattern.
- Tighten to 14 Nm (10 lb-ft).

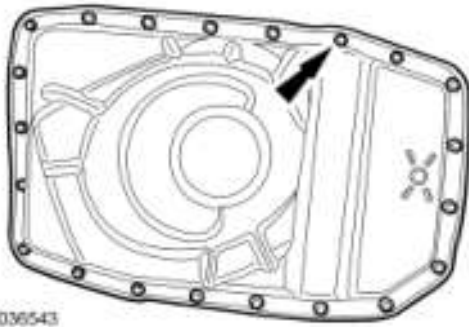

Fig. 105: Locating Transmission Fluid Pan Bolts
Courtesy of FORD MOTOR CO.

16. Connect the main transmission electrical harness by pushing it in and twisting the outer shell to lock it in place.

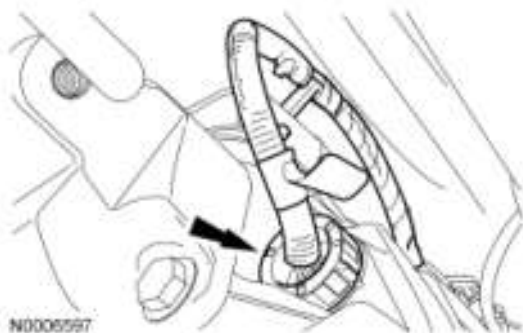

Fig. 106: Locating Main Transmission Electrical Harness Connector
Courtesy of FORD MOTOR CO.

NOTE: When installing the selector lever cable, make sure that the selector lever cable locking tabs are locked in place and the cable end is snapped onto the ball stud. Press the selector lever cable into the bracket and listen for the cable to click into place. Pull back on the

selector lever cable to make sure that it is locked into the bracket. Also, make sure that the selector lever cable end is correctly installed onto the ball stud. Pull back on the selector lever cable to make sure that the cable end is correctly installed.

17. Connect the selector lever cable onto the ball stud and move the locking tab down.
 - Listen for the audible click.
 - Pull back on the selector lever cable to make sure that it is correctly installed.

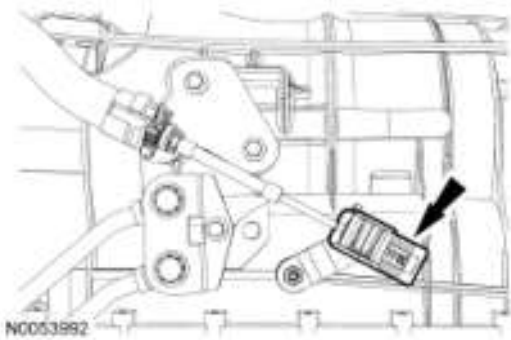

Fig. 107: Locating Selector Lever Cable
Courtesy of FORD MOTOR CO.

18. Using the refill procedure, fill and check the transmission fluid. For additional information, refer to **Transmission Fluid Drain and Refill.**