













ASSEMBLY

TRANSMISSION

Special Tools

Illustration	Tool Name	Tool Number
 ST1214-A	Dial Indicator Gauge with Holding Fixture	100-002 (TOOL-4201-C)
 ST2850-A	Installer, Shifter Fluid Seal	307-559
 ST1631-A	Handle, Torque Converter	307-091 (T81P-7902-C)
 ST2888-A	Installer, Transmission Extension Housing Fluid Seal	307-560
 ST2887-A	Installer, Fluid Pump Seal	307-556
 ST1104-B	Retaining Ring Pliers	307-343 (T95P-77001-AHR)
 ST1754-A	Aligner, Valve Body	307-334 (T95L-70010-C)
	Installer, Ball Bearing	307-557

 <p>ST2895-A</p>		
 <p>ST2894-A</p>	Installer, Needle Bearing	307-558
 <p>ST2891-A</p>	Remover, Transmission Fluid Pump	307-553
 <p>ST1255-A</p>	Handle, Driver	205-153 (T80T-4000-W)
 <p>ST2883-A</p>	End Play Gauge, Transmission	307-534

Material

Item	Specification
MERCON® SP Automatic Transmission Fluid XT-6-QSP (US); CXT-6-LSP12 (Canada)	MERCON® SP
Multi-Purpose Grease XG-4 and/or XL-5	ESB-M1C93-B

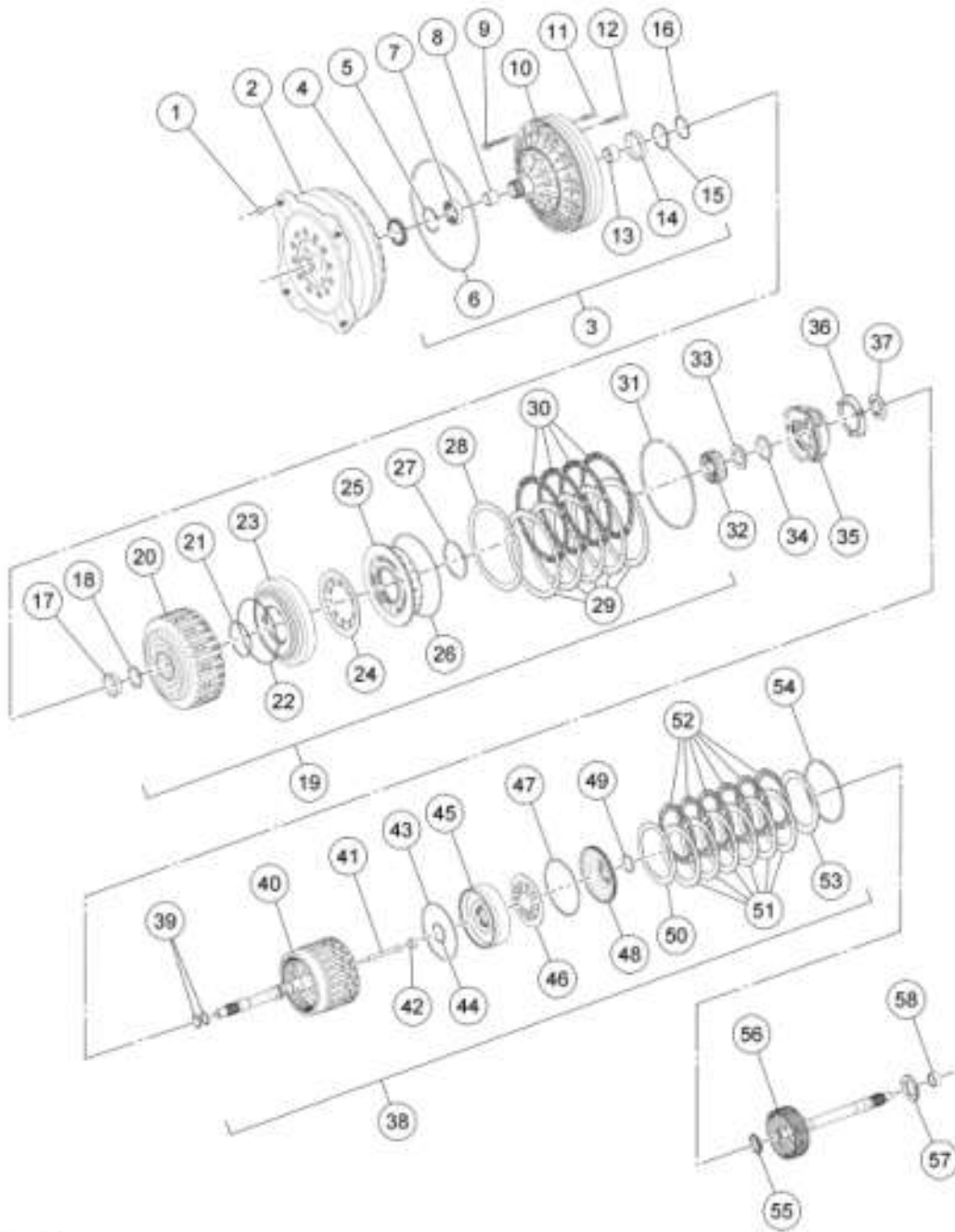

N0062991

Fig. 369: Exploded View Of Transmission Assembly Disassembled Views (1 Of 3)
 Courtesy of FORD MOTOR CO.

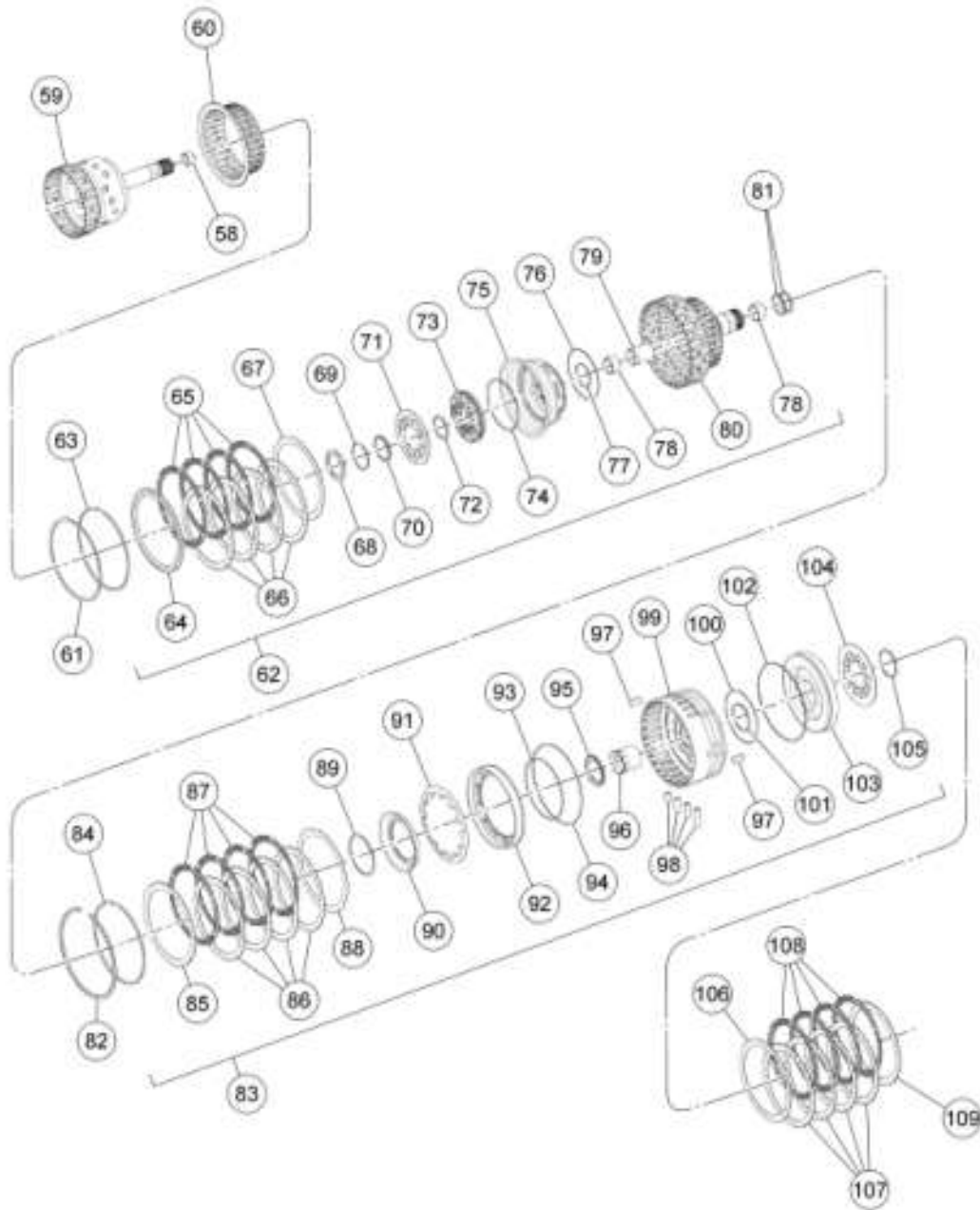

N0062992

Fig. 370: Exploded View Of Transmission Assembly Disassembled Views (2 Of 3)
 Courtesy of FORD MOTOR CO.

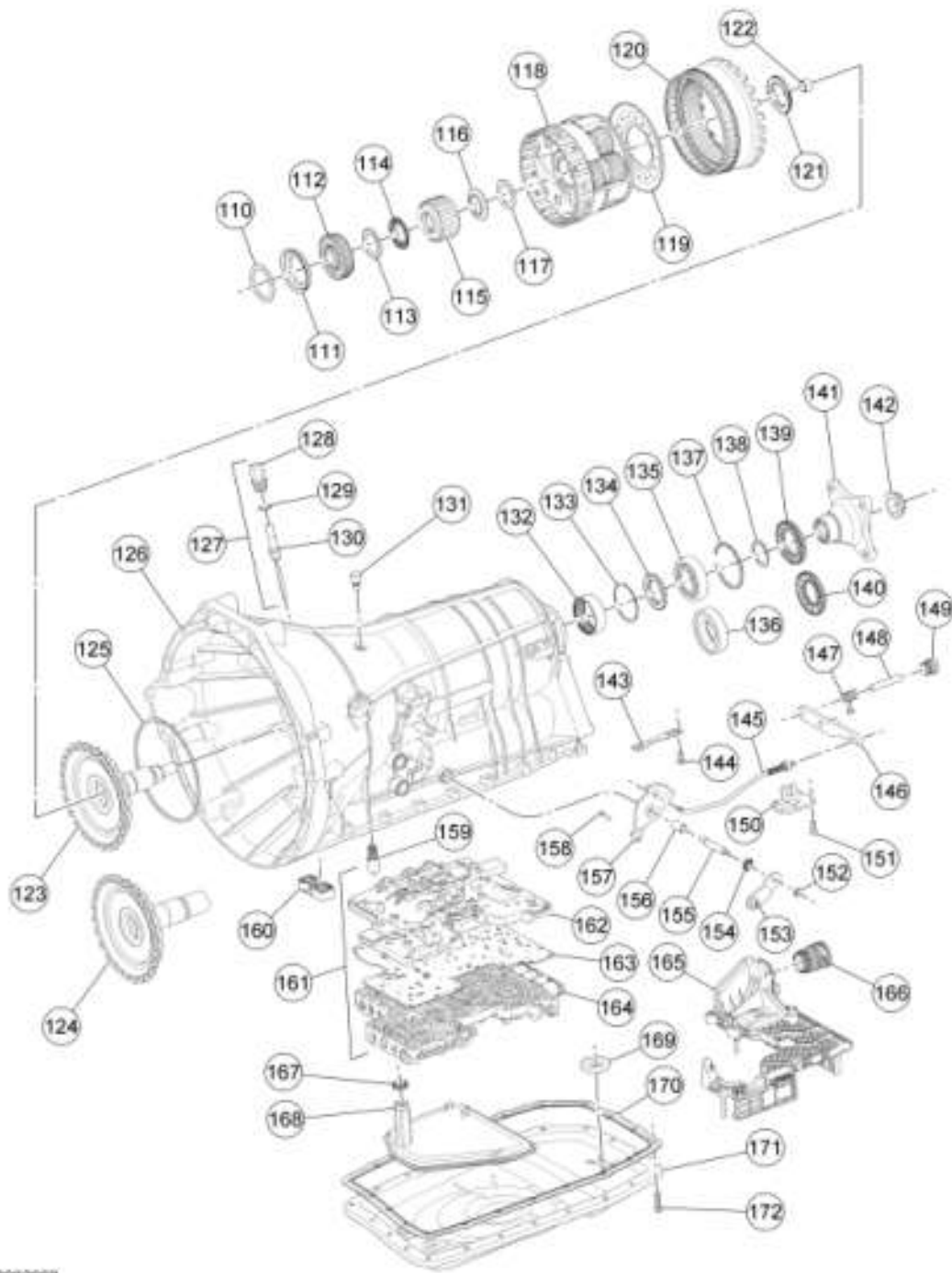

N0062993

Fig. 371: Exploded View Of Transmission Assembly Disassembled Views (3 Of 3)
 Courtesy of FORD MOTOR CO.

Item	Part Number	Description
1	N800750-S437	Flex plate-to-torque converter nut (4 required)
2	7902	Torque converter
3	7A103	Pump assembly
4	7A248	Front pump oil seal
5	7N877	Torque converter pump retaining ring
6	7B031	Front pump outer oil seal

7	7R166	Front oil pump bearing assembly
8	7N817	Bushing converter stator support
9	7N134	Front pump-to-case bolts (13 required)
10	7A103	Front pump assembly
11	7R078	Bolt - attaches stator support to pump adapter assembly (6 required)
12	W707871-S300	Bolt - attaches pump to pump adapter assembly (11 required)
13	7B261	Converter stator support bushing
14	7G427	Front bushing forward clutch drum
15	7Z463	Clutch support fluid seal
16	7L323	Front pump support seal
17	7G428	Forward clutch rear bushing
18	7D014	Front pump support thrust washer
19	7A511	Forward clutch assembly (clutch A)
20	7J011	Forward clutch cylinder and hub assembly
21	7G242	Forward clutch inner piston seal
22	7F227	Forward clutch outer piston seal
23	7L140	Forward clutch piston
24	7F230	Forward clutch piston retaining spring
25	7J032	Forward clutch balance piston assembly
26	7F227	Forward clutch balance piston outer seal
27	7H365	Forward clutch balance piston snap ring
28	7N572	Forward clutch cushion spring
29	7E314	Forward clutch steel plates (externally splined) (number model dependent)
30	7B164	Forward clutch friction plates (internally splined) (number model dependent)
31	7B421	Pressure plate retaining snap ring
32	7G231	Front planetary sun gear (No. 1)
33	7H375	Bearing (T1)
34	7H579	Front planetary carrier assembly snap ring
35	7G218	Front planetary carrier assembly
36	7H578	Plate transmission fluid collector
37	7L495	Bearing (T2)
38	7L668	Overdrive clutch assembly (clutch E)
39	7G091	Turbine shaft seals (2 required)
40	7J006	Input shaft
41	7C232	Fluid distributor sleeve
42	7B256	Output shaft bushing
43	7J008	Overdrive clutch piston outer seal
44	7G007	Overdrive clutch piston inner seal
45	7G418	Overdrive clutch piston
46	7N529	Overdrive clutch piston spring
47	7J009	Balance piston outer seal

48	7J029	Overdrive balance piston
49	7J010	Balance piston snap ring
50	7N572	Clutch cushion plate
51	7B442	Overdrive clutch steel plates (externally splined) (number model dependent)
52	7B164	Overdrive clutch friction plates (internally splined) (number model dependent)
53	7C576	Overdrive pressure plate
54	7M157	Overdrive clutch retaining ring
55	7A453	Bearing (T3)
56	7F351	Intermediate clutch shaft
57	7H375	Bearing (T4)
58	7D065	Sun gear bushings (2 required) (part of 7R193)
59	7R193	Sun gear hub and shaft assembly
60	7F236	Direct clutch hub
61	7H076	Direct clutch cylinder retaining ring
62	7C108	Direct clutch assembly (clutch B)
63	7B421	Direct clutch pressure plate retaining ring
64	7B477	Direct clutch pressure plate
65	7B164	Direct clutch friction plates (internally splined) (number model dependent)
66	7E314	Direct clutch steel plates (externally splined) (number model dependent)
67	7N572	Direct clutch cushion plate
68	7D283	Bearing (T5)
69	7H363	Direct clutch balance piston snap ring
70	7D427	Direct clutch piston spring retainer
71	7B488	Direct clutch piston return spring
72	7B492	Direct clutch piston retaining ring
73	7H359	Direct clutch balance piston
74	7C000	Direct clutch balance seal
75	7F254	Direct clutch piston
76	7C000	Direct clutch piston outer seal
77	7F234	Direct clutch piston inner seal
78	7H240	Direct clutch hub bushings (part of 7F281) (2 required)
79	7C486	Gear shaft tube sleeve
80	7F360	Direct clutch cylinder
81	7B399	Shell cylinder seals (2 required)
82	7L327	Center support retaining ring
83	7F388	Intermediate clutch assembly (clutch C)
84	7B421	Intermediate clutch pressure plate retaining ring
85	7E314	Intermediate clutch pressure plate
86	7E314	Intermediate clutch steel plates (externally splined) (number model dependent)
87	7B164	Intermediate clutch friction plates (internally splined)

		(number model dependent)
88	7H136	Intermediate clutch pressure plate spring
89	7N169	Intermediate clutch retaining ring
90	7B043	Intermediate clutch ring
91	7C151	Intermediate clutch piston spring
92	7J015	Intermediate clutch piston
93	7F225	Intermediate clutch piston inner seal
94	7F224	Intermediate clutch piston outer seal
95	7F373	Bearing (T6)
96	7B314	Center shaft sleeve (part of 7G033)
97	7J114	Center support keys (2 required)
98	7J135	Center support seals (4 required)
99	7G033	Support assembly
100	7G446	Low/reverse clutch piston center seal
101	7G444	Low/reverse clutch piston inner seal
102	7G445	Low/reverse clutch piston outer seal
103	7D343	Low/reverse clutch piston
104	7D405	Low/reverse clutch piston return spring
105	7G494	Low/reverse clutch piston retaining ring
106	7N572	Clutch disc cushion plate
107	7E314	Low/reverse clutch steel plates (externally splined) (number model dependent)
108	7B164	Low/reverse clutch friction plates (internally splined) (number model dependent)
109	7E314	Low/reverse clutch pressure plate (select fit)
110	7H286	Gear thrust shim (select fit)
111	7C041	Bearing (T7)
112	7H580	Sun gear No. 2
113	7D235	Thrust bearing outer race
114	7D234	Bearing (T8)
115	7A348	Sun gear No. 3
116	7D234	Bearing (T9)
117	7193	Bearing race (T9)
118	7G224	Rear planetary carrier assembly
119	7H583	Fluid collar rear planetary plate (part of 7G224)
120	7A153	Output shaft ring gear assembly
121	7M152	Bearing (T10)
122	7B256	Output shaft bushing (part of 7096)
123	7096	Output shaft parking gear assembly (rear wheel drive [RWD])
124	7096	Output shaft parking gear assembly (four wheel drive [4WD])
125	7N194	Output shaft retaining ring
126	7006	Transmission case assembly (model dependent)
127	7E389	Transmission case fluid fill plug assembly

128	7E380	Transmission case fluid fill plug
129	7E390	Transmission case fluid fill seal
130	7E049	Transmission oil level indicator
131	7034	Transmission case vent assembly (model dependent)
132	7A415	Output shaft bearing assembly
133	7030A	Output shaft retaining ring
134	7E413	Bearing (T11) (4WD only)
135	7R205	Output shaft bearing (RWD only)
136	7A433	Output shaft spacer (4WD only)
137	7030B	Output shaft bearing retainer shim
138	7N135	Anti-click washer
139	7052	Extension housing seal (RWD)
140	7052	Extension housing seal (4WD)
141	7A021	Output shaft flange (RWD)
142	7K440	Output shaft flange retaining nut (RWD)
143	7E332	Manual valve detent spring
144	W711235-S300	Manual valve detent spring retaining screw and washer
145	7D410	Parking pawl actuating rod
146	7A441	Parking pawl
147	7D070	Parking pawl return spring
148	7D071	Parking pawl shaft
149	7H398	Plug assembly transmission case housing
150	7G101	Parking pawl abutment
151	W711235-S300	Parking pawl abutment retaining screw and washer
152	W708455-S441	Manual control lever nut
153	7A256	Manual control lever
154	7B498	Manual control lever shaft seal
155	7C493	Manual control lever shaft
156	7C257	Manual control lever shaft spacer
157	7A115	Manual valve detent lever assembly
158	7G100	Manual valve detent lever retaining pin
159	7H322	Thermal bypass valve
160	7F401	Front pump adapter seal
161	7A100	Main control assembly
162	7A091	Main control valve body assembly
163	7Z490	Main control valve body separator plate
164	7G423	Lower main control valve body
165	14C247	Control module assembly
166	7H585	Bulkhead connector sleeve
167	-	Transmission fluid filter seal (part of 7G186)
168	7G186	Transmission fluid filter
169	-	Transmission fluid pan magnet
170	7A191	Transmission fluid pan gasket
171	7A194	Transmission fluid pan
172		

All vehicles

1. If removed, position the rear case roller bearing in the case.

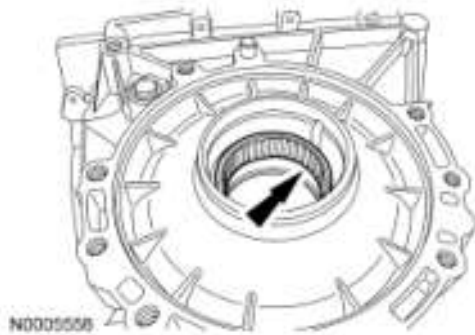

Fig. 372: Locating Rear Case Roller Bearing
Courtesy of FORD MOTOR CO.

2. Using the special tools, install the roller bearing.

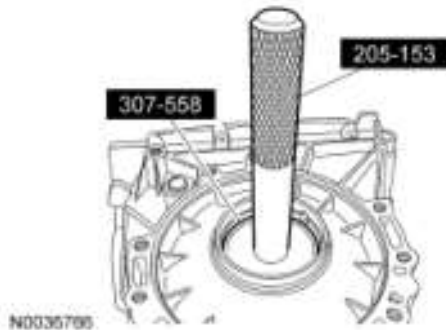

Fig. 373: Installing Roller Bearing Using Special Tools (205-153, 307-558)
Courtesy of FORD MOTOR CO.

3. Install the snap ring.

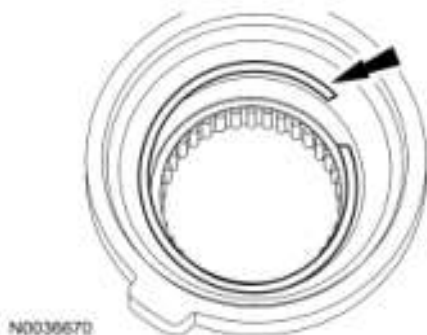

Fig. 374: Locating Inner Bearing Snap Ring
Courtesy of FORD MOTOR CO.

Rear wheel drive (RWD) vehicles

- Using the special tools, install the rear case roller bearing in the case.

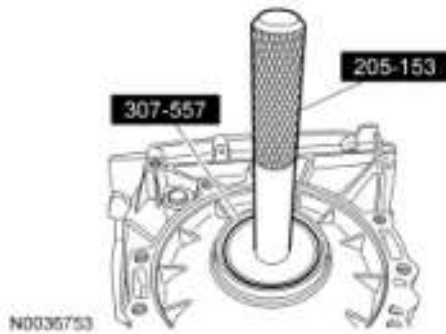

Fig. 375: Installing Rear Case Roller Bearing Using Special Tools (205-153, 307-557)
Courtesy of FORD MOTOR CO.

- Install the roller bearing snap ring.

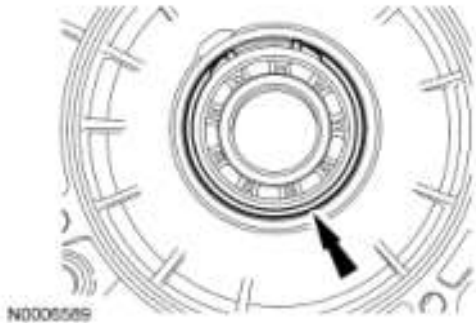

Fig. 376: Locating Snap Ring From Case
Courtesy of FORD MOTOR CO.

Four wheel drive (4WD) vehicles

- Using the special tools, install the rear bearing spacer.

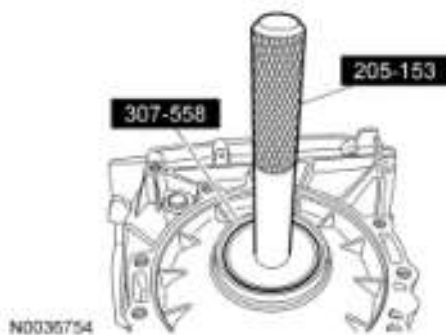

Fig. 377: Installing Rear Bearing Spacer Using Special Tools (205-153, 307-558)
Courtesy of FORD MOTOR CO.

- Install the rear bearing spacer snap ring.

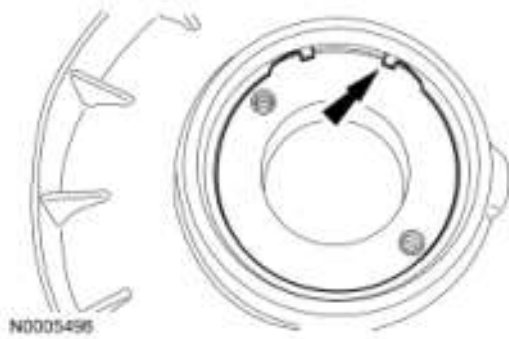

Fig. 378: Locating Snap Ring
 Courtesy of FORD MOTOR CO.

All vehicles

8. Place the transmission in the vertical position.
9. Install the planet carrier hub and output shaft assembly.

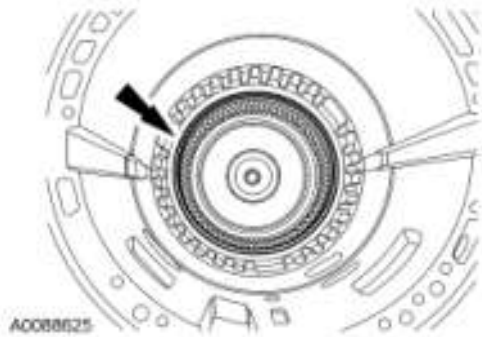

Fig. 379: Locating Planet Carrier Hub & Output Shaft Assembly
 Courtesy of FORD MOTOR CO.

10. Install the silver shim (caged bearing) on the planet carrier hub and output shaft assembly.

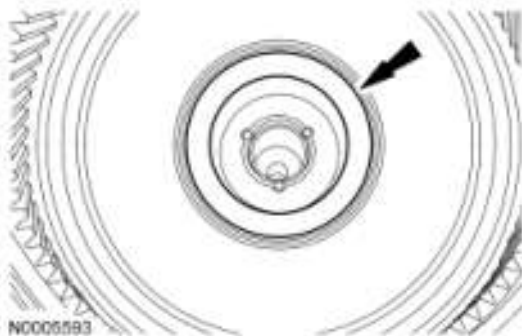

Fig. 380: Locating Silver Shim On Planet Carrier Hub
 Courtesy of FORD MOTOR CO.

11. Position the park pawl pin into the case.



Fig. 381: Positioning Park Pawl Pin Into Case
Courtesy of FORD MOTOR CO.

12. Position the park pawl into the case and push the park pawl pin in to hold the park pawl and spring in position.

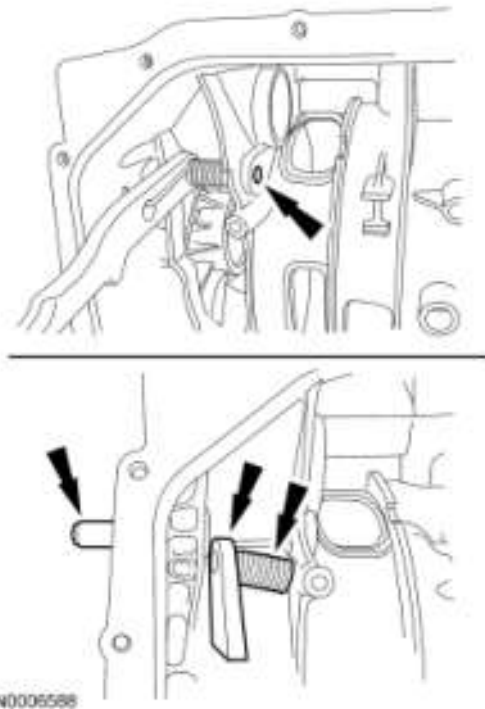
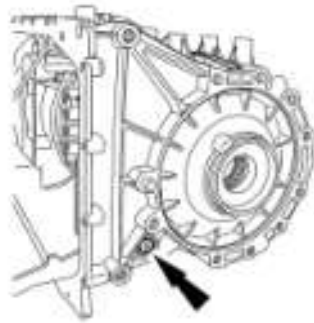

Fig. 382: Locating Park Pawl Pin, Park Pawl & Spring
Courtesy of FORD MOTOR CO.

13. Install the park pawl pin bolt.
 - Tighten to 35 Nm (26 lb-ft).



N0005567

Fig. 383: Locating Park Pawl Pin Bolt
Courtesy of FORD MOTOR CO.

4WD vehicles

14. Position a new output shaft seal in place.

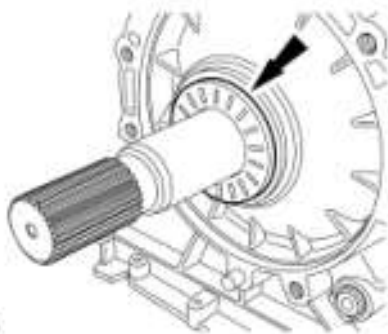

N0005605

Fig. 384: Positioning Output Shaft Seal In Place
Courtesy of FORD MOTOR CO.

15. Using the special tool, install the output shaft seal.

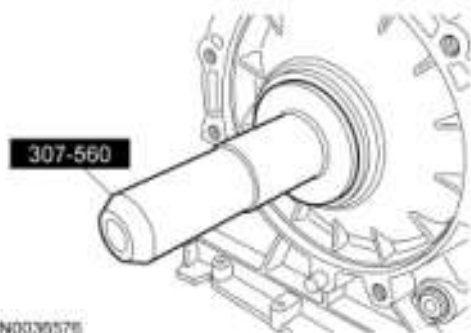

N0039576

Fig. 385: Locating Output Shaft Seal
Courtesy of FORD MOTOR CO.

RWD vehicles

16. Install the anti-click washer.

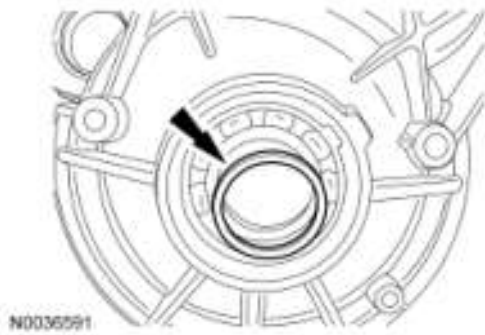

Fig. 386: Locating Anti-Click Washer
Courtesy of FORD MOTOR CO.

17. Position a new output shaft seal in place.

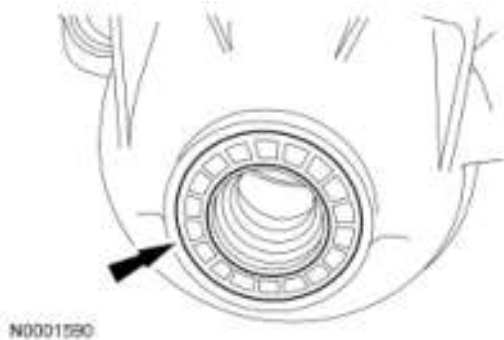

Fig. 387: Locating Output Shaft Seal
Courtesy of FORD MOTOR CO.

18. Using the special tool, install the output shaft seal.

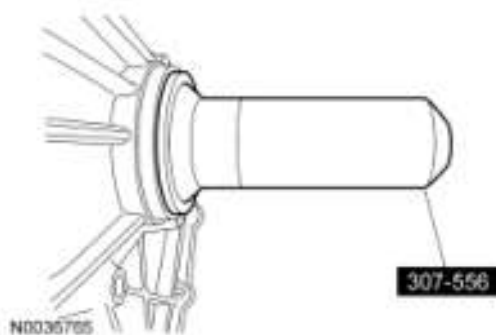

Fig. 388: Installing Output Shaft Seal Using Special Tool (307-556)
Courtesy of FORD MOTOR CO.

19. Install the output shaft flange.

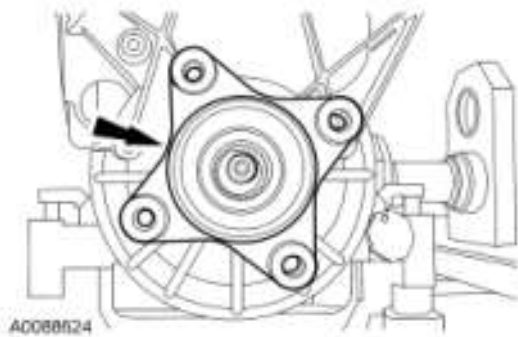

Fig. 389: Locating Output Shaft Flange
Courtesy of FORD MOTOR CO.

20. Install a new output shaft flange nut.
 - Tighten to 60 Nm (44 lb-ft).
 - After installing the new nut, it must be staked at the slots to prevent it from coming loose.

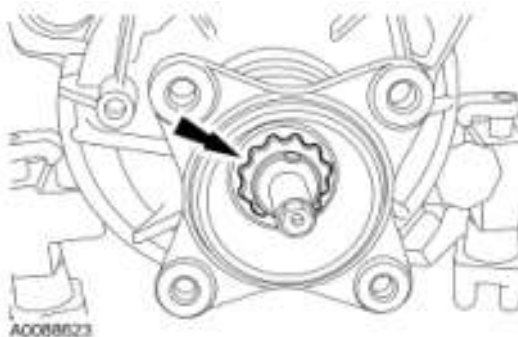

Fig. 390: Locating Output Shaft Flange Nut
Courtesy of FORD MOTOR CO.

21. Install the rear transmission mount bracket.
 - Tighten to 48 Nm (35 lb-ft).

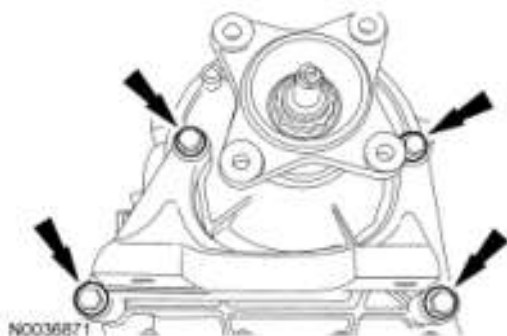

Fig. 391: Locating Transmission Mount Bracket Bolts
Courtesy of FORD MOTOR CO.

All vehicles

22. Install the roller bearing race in the bottom of the carrier.

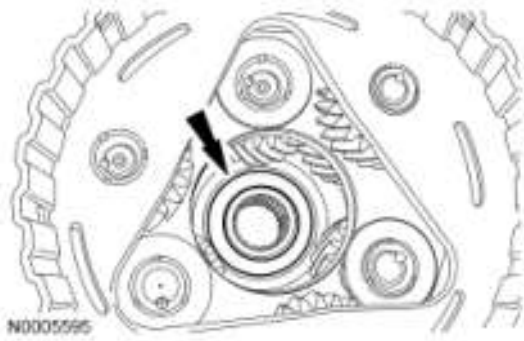

Fig. 392: Locating Roller Bearing Race
 Courtesy of FORD MOTOR CO.

23. Snap the top and the bottom roller bearings onto the sun gear.

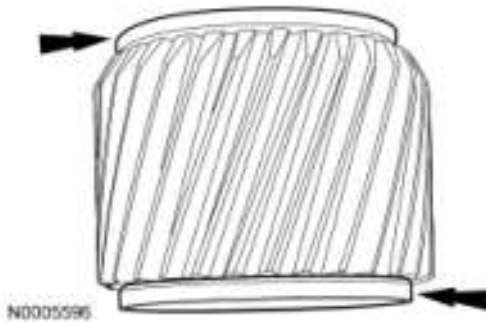

Fig. 393: Locating Roller Bearings From Sun Gear
 Courtesy of FORD MOTOR CO.

NOTE: When installing the sun gear, make sure that the taper edge is facing up toward the torque converter housing.

24. Install the sun gear into the planet assembly.



Fig. 394: Locating Sun Gear Into Planet Assembly
 Courtesy of FORD MOTOR CO.

25. Install the low/reverse sun gear.



Fig. 395: Locating Low/Reverse Sun Gear
Courtesy of FORD MOTOR CO.

26. Install the low/reverse thrust bearing (T7).

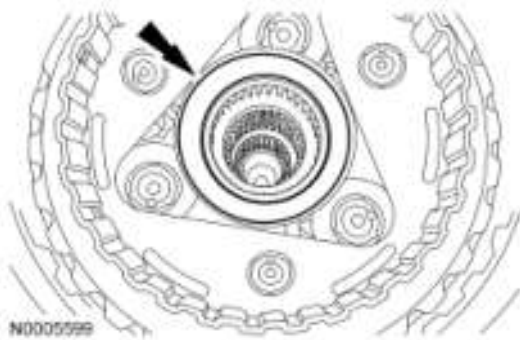

Fig. 396: Locating Low/Reverse Bearing Race
Courtesy of FORD MOTOR CO.

NOTE: **Inspect and install new thrust bearings as required.**

27. Install the select fit thrust gear shim.
28. Install the planet carrier.

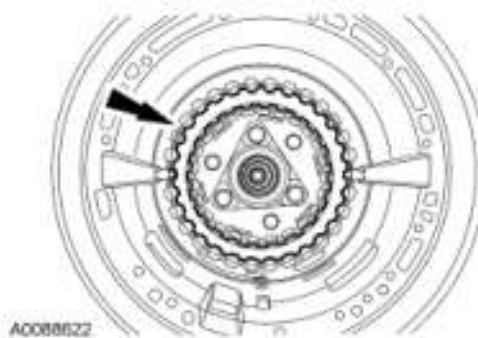

Fig. 397: Locating Low/Reverse Clutch Pack
Courtesy of FORD MOTOR CO.

29. Install the low/reverse clutch plates, starting with the pressure plate and alternating between the friction and steel plates, and ending with the wave spring plate on the top.

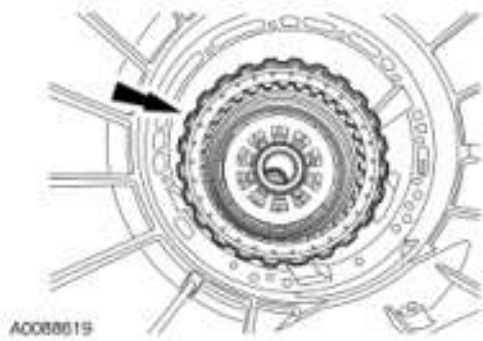

Fig. 398: Locating Low/Reverse Clutch Plates
Courtesy of FORD MOTOR CO.

30. Install the roller bearing and shim onto the center support.

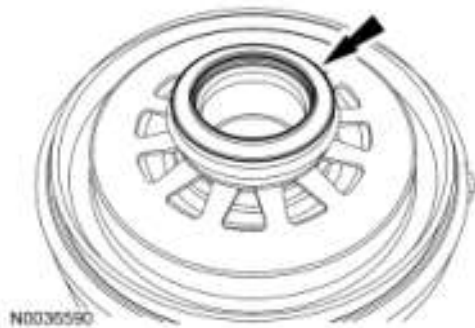

Fig. 399: Locating Bearing From Back Of Center Support
Courtesy of FORD MOTOR CO.

NOTE: Make sure that when installing the center support the feed holes on the center support are lined up with the feed holes in the case.

31. Install the center support into the case.

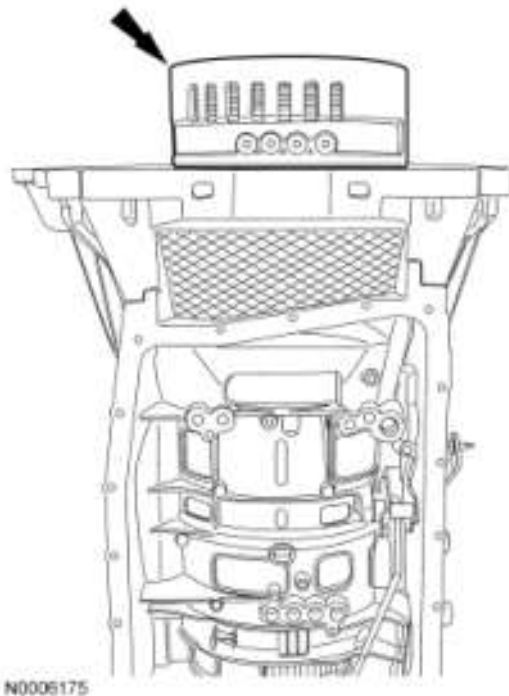

Fig. 400: Locating Center Support Into Case
 Courtesy of FORD MOTOR CO.

NOTE: Rotate case 180 degrees.

32. Using the special tool, install the center support snap ring. Tap the snap ring into the case to make sure that it is seated into the case.

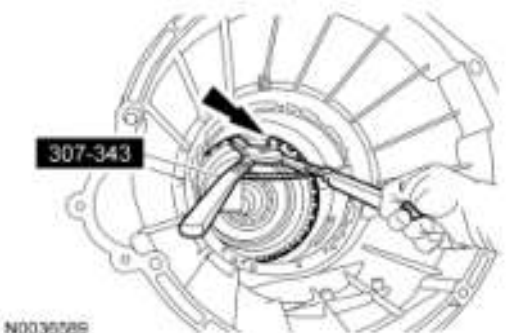

Fig. 401: Installing Center Support Snap Ring Using Special Tool (307-343)
 Courtesy of FORD MOTOR CO.

33. Using the special tool, lift up on the output shaft and record the reading. The reading should be within 0.15-0.35 mm (0.006-0.013 in).
 - If the reading is not within the specification, install a different (either thinner or thicker) select fit thrust gear shim.

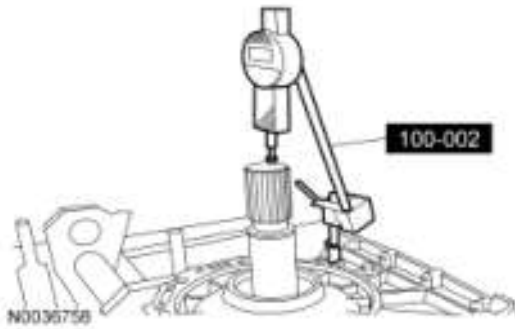

Fig. 402: Lifting Up On Output Shaft & Record Reading Using Special Tool (100-002)
Courtesy of FORD MOTOR CO.

34. Install the roller bearing if not previously installed on the direct clutch drum.

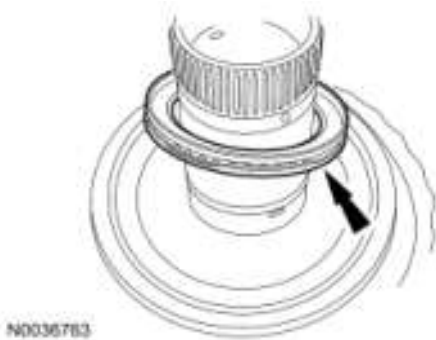

Fig. 403: Locating Roller Bearing
Courtesy of FORD MOTOR CO.

35. Install the direct clutch drum.

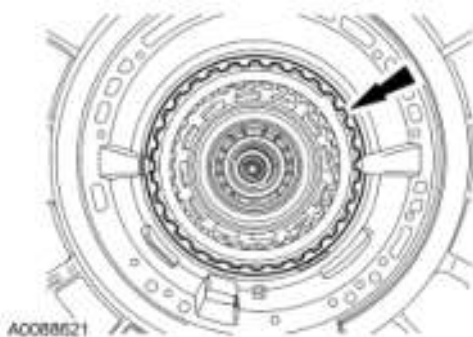

Fig. 404: Locating Center Support
Courtesy of FORD MOTOR CO.

36. Install the bearing on the direct clutch assembly.

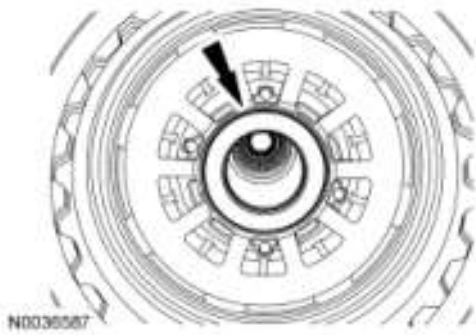

Fig. 405: Locating Caged Roller Bearing
Courtesy of FORD MOTOR CO.

37. Install the forward and overdrive clutch assembly.

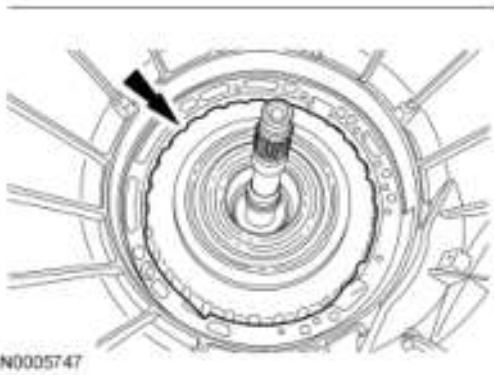
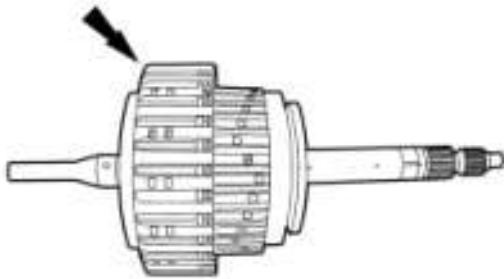

Fig. 406: Locating Forward And Overdrive Clutch Assembly
Courtesy of FORD MOTOR CO.

38. Install the pump washer.

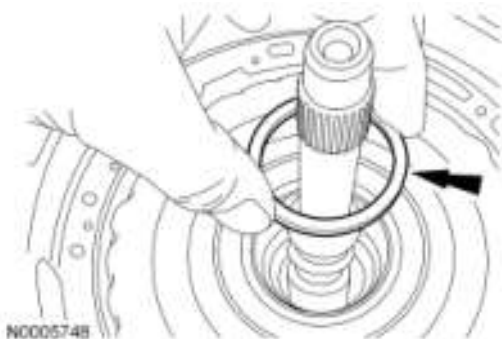

Fig. 407: Locating Pump Washer

Courtesy of FORD MOTOR CO.

39. Install the special tool into the case.

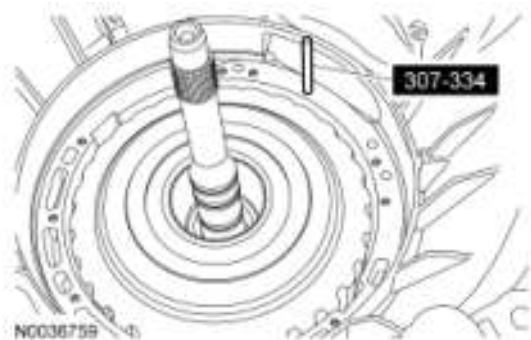

Fig. 408: Installing Special Tool (307-334) Into Case
Courtesy of FORD MOTOR CO.

40. Using the special tools, install the front pump.

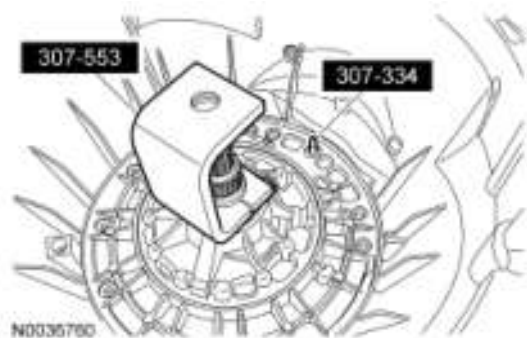

Fig. 409: Install Front Pump Using Special Tools (307-334, 307-553)
Courtesy of FORD MOTOR CO.

NOTE: Make sure that the fluid filter seal has been removed. If it has not, use a suitable pick and remove the seal.

NOTE: Add 0.118L (4 oz.) of clean transmission fluid to prime the pump.

41. Make sure that the pump is correctly aligned with the case.



Fig. 410: Locating Case
Courtesy of FORD MOTOR CO.

42. Loosely install the new front pump bolts with the new washers.

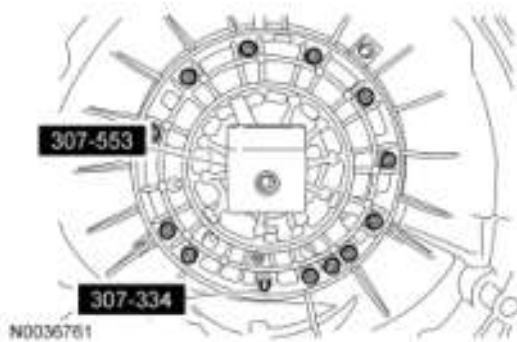

Fig. 411: Identifying Special Tools (307-334, 307-553)
Courtesy of FORD MOTOR CO.

43. Install the remaining front pump bolt. Tighten the bolts in a crisscross pattern.

- Tighten to 10 Nm (89 lb-in).

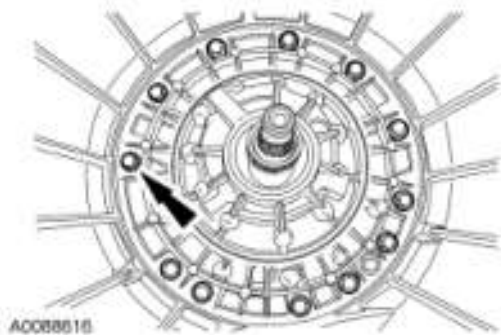

Fig. 412: Locating Front Pump Bolts
Courtesy of FORD MOTOR CO.

44. Install the special tool onto the input shaft to measure end play.

- Tighten the wing nut.

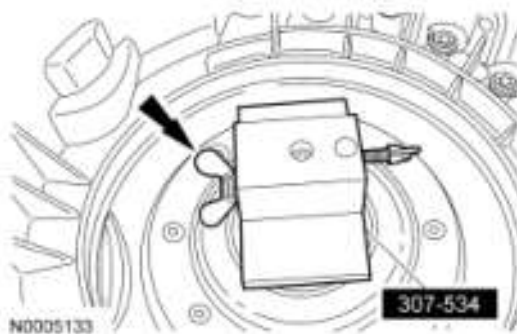

Fig. 413: Installing Special Tool (307-534) Onto Input Shaft
Courtesy of FORD MOTOR CO.

45. Install the remaining special tool.

- Push down on the special tool and zero out the dial indicator.
- Lift up on the special tool and record the measurement 0.2-0.4 mm (0.008-0.015 in). If the

measurement is not within specification install a new pump washer.

- Measure the original washer, install a thinner or a thicker washer to achieve the correct measurement.

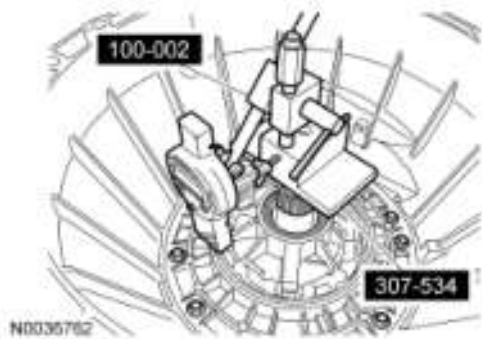

Fig. 414: Identifying Special Tools (100-002, 307-534)
Courtesy of FORD MOTOR CO.

46. Install the park pawl abutment.
 - Tighten to 10 Nm (89 lb-in).

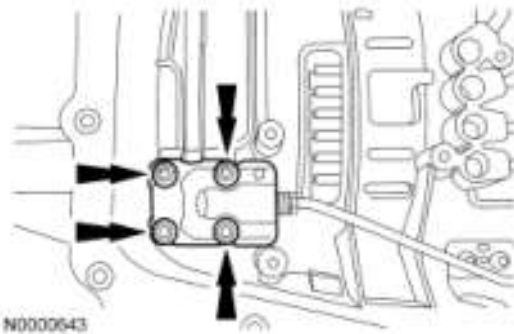

Fig. 415: Locating Park Pawl Abutment
Courtesy of FORD MOTOR CO.

47. Position a new manual control lever seal in place.

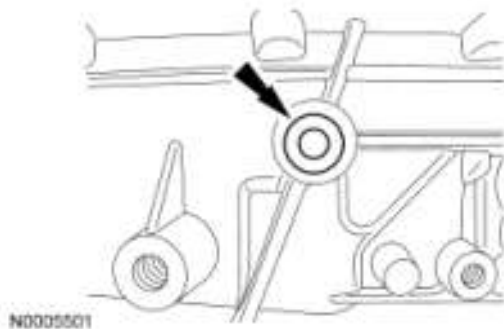

Fig. 416: Locating Manual Control Lever Seal
Courtesy of FORD MOTOR CO.

48. Using the special tool, install a new manual control lever shaft seal.

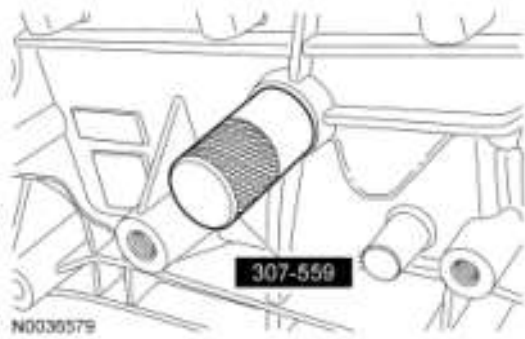

Fig. 417: Installing Manual Control Lever Shaft Seal Using Special Tool (307-559)
 Courtesy of FORD MOTOR CO.

49. Position the manual lever and park rod in place.
 - Push down on the park pawl and slide the park rod in place.

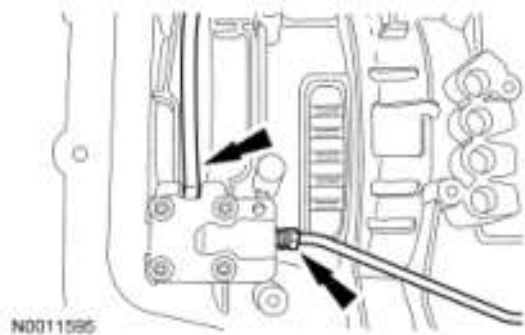

Fig. 418: Locating Manual Lever And Park Rod
 Courtesy of FORD MOTOR CO.

50. Install the manual lever in the case.
 1. Slide the manual lever in the case.
 2. Position the spacer in place while sliding the manual lever into the spacer.
 3. Position the manual valve inner lever while sliding the manual lever and lining up the roll pin hole.
 4. Install the roll pin.

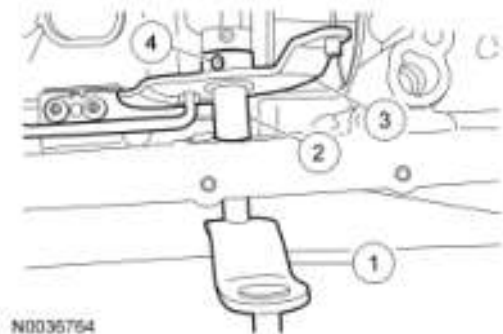

Fig. 419: Identifying Manual Lever, Spacer, Manual Valve Inner Lever, Roll Pin
 Courtesy of FORD MOTOR CO.

51. Install the 4 rubber feed tubes for the center support.

1. Black feed tube.
2. Green feed tube.
3. Blue feed tube.

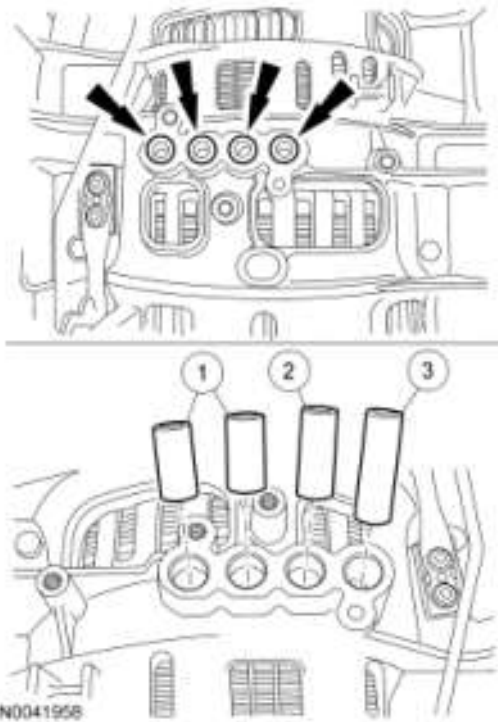

Fig. 420: Locating Rubber Feed Tubes
Courtesy of FORD MOTOR CO.

52. Install the thermal bypass valve into the case.

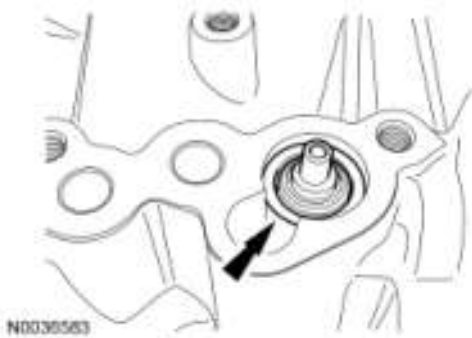

Fig. 421: Locating Thermal Bypass Valve
Courtesy of FORD MOTOR CO.

53. Install the rubber adapter.



Fig. 422: Locating Rubber Adapter
 Courtesy of FORD MOTOR CO.

NOTE: The mechatronic assembly will not lay flush on the case, this is normal, the bolts will pull the mechatronic assembly down.

54. Loosely install the 11 mechatronic bolts.
 1. Align the manual valve and control lever linkage.

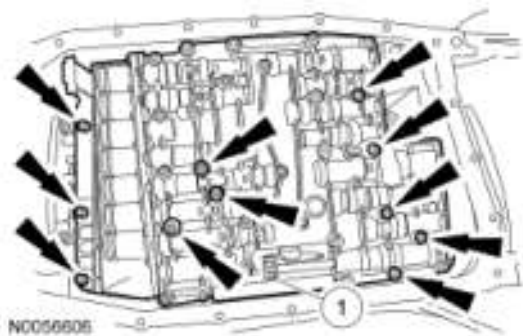

Fig. 423: Locating Mechatronic Assembly Bolts
 Courtesy of FORD MOTOR CO.

CAUTION: Do not touch the electrical connector pins or the exposed solenoid tabs on the transmission control module (TCM). Electrostatic discharge may occur and may cause damage to the mechatronic unit.

55. Tighten the bolts in the sequence shown.
 - Tighten to 6 Nm (53 lb-in).

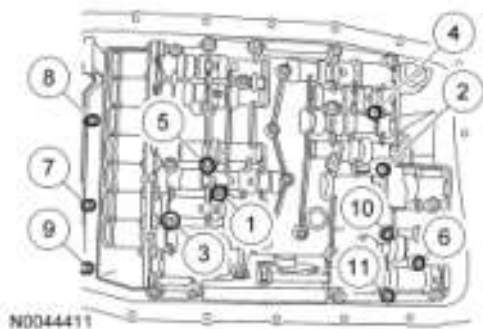
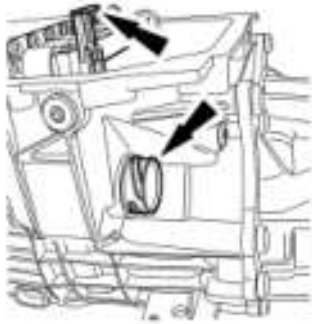

Fig. 424: Tightening Mechatronic Bolts In Sequence
Courtesy of FORD MOTOR CO.

CAUTION: Do not touch the electrical connector pins or the exposed solenoid tabs on the transmission control module (TCM). Electrostatic discharge may occur and may cause damage to the mechatronic unit.

56. With the release tab up and unlocked, push the outer shell of the bulkhead electrical connector into the transmission. Make sure that the bulkhead connector is fully seated into the TCM.



N0005491

Fig. 425: Locating Outer Shell Of Bulkhead Electrical Connector And Release Tab
Courtesy of FORD MOTOR CO.

57. Press down on the tab and lock the outer shell of the bulkhead electrical connector in place. Make sure that the locking tab is securely locked.

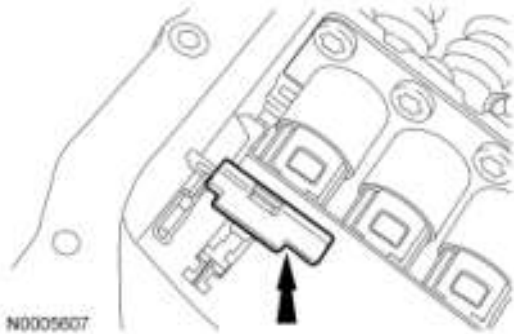

N0005607

Fig. 426: Locating Outer Shell Of Bulkhead Electrical Connector And Tab
Courtesy of FORD MOTOR CO.

58. Install a new transmission fluid filter.

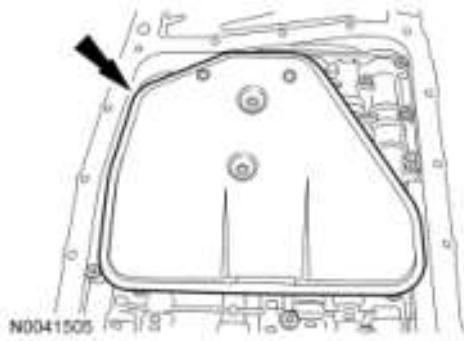

Fig. 427: Locating Transmission Fluid Filter
 Courtesy of FORD MOTOR CO.

NOTE: The fluid pan gasket can be reused if not damaged.

59. Install a new transmission fluid pan gasket if required.

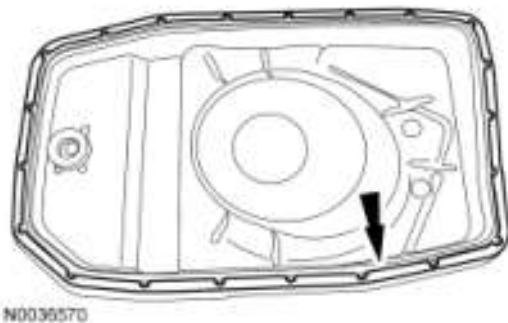

Fig. 428: Locating Transmission Fluid Pan Gasket
 Courtesy of FORD MOTOR CO.

60. Install the fluid pan and tighten the bolts in a crisscross pattern.
 - Tighten to 14 Nm (10 lb-ft).

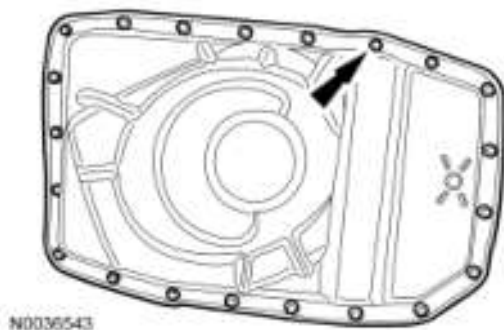

Fig. 429: Locating Transmission Fluid Pan Bolts
 Courtesy of FORD MOTOR CO.

61. Install the torque converter.

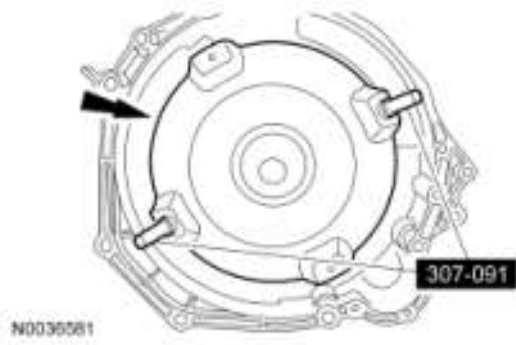

Fig. 430: Installing Torque Converter Using Special Tool (307-091)
Courtesy of FORD MOTOR CO.