

INSTALLATION

TRANSMISSION - FOUR WHEEL DRIVE (4WD)

Special Tools

Illustration	Tool Name	Tool Number
	Retainer, Torque Converter	307-346 (T97T-7902-A)

Material

Item	Specification
MERCON® SP Automatic Transmission Fluid XT-6-QSP (US); CXT-6-LSP12 (Canada)	MERCON® SP

INSTALLATION

1. Install the special tool.

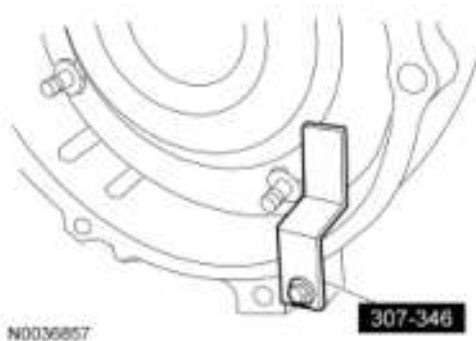

Fig. 431: Identifying Special Tool (307-346)
Courtesy of FORD MOTOR CO.

CAUTION: The converter housing is piloted into position by dowels in the rear of the engine block. The torque converter must rest squarely against the flexplate. This indicates that the converter pilot is not binding in the engine crankshaft.

2. Position and secure the transmission on the high-lift transmission jack. Raise and position the transmission into the vehicle.
3. Remove the special tool.

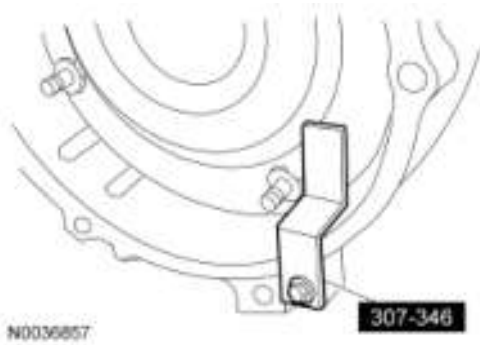

Fig. 432: Identifying Special Tool (307-346)
 Courtesy of FORD MOTOR CO.

NOTE: Make sure the torque converter is fully seated in the transmission before aligning the transmission to the engine.

4. With the transmission in a horizontal position, move it toward the engine. Align the orange balancing marks between the torque converter studs and the flexplate bolt holes.

NOTE: Install the 7 transmission-to-engine bolts in their correct locations noted during removal.

NOTE: The top 2 transmission-to-engine bolts need to be installed prior to installing the rest of the bolts.

5. Install the 7 transmission-to-engine bolts.
 - Tighten to 48 Nm (35 lb-ft).

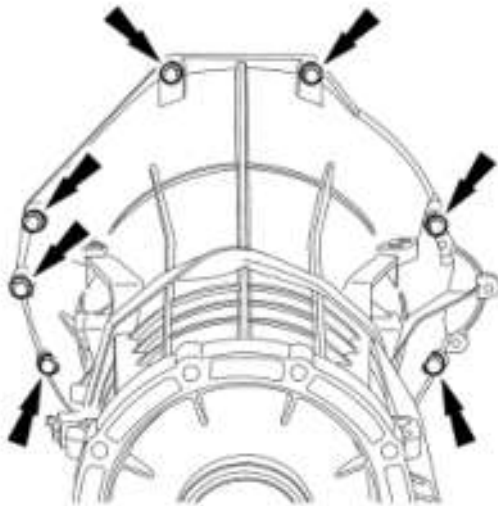

N0036855

Fig. 433: Locating Transmission-To-Engine Bolts

Courtesy of FORD MOTOR CO.

6. Connect the main transmission electrical harness by pushing it in and twisting the outer shell to lock it in place.

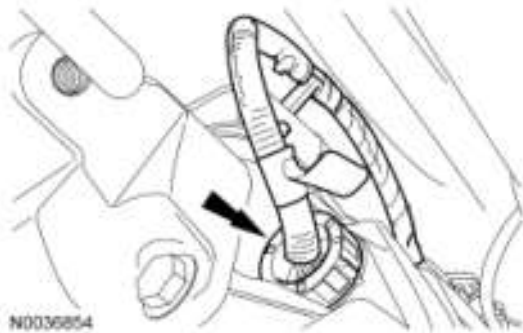

Fig. 434: Locating Main Transmission Electrical Harness
Courtesy of FORD MOTOR CO.

7. Connect the wire harness to the top of the transmission.



Fig. 435: Locating Wire Harness From Top Of Transmission
Courtesy of FORD MOTOR CO.

8. Install the catalyst monitor sensor electrical connector to the LH side of the transmission.

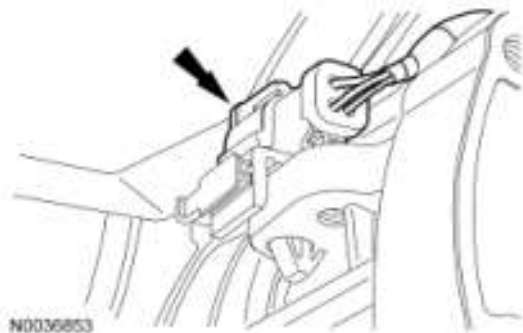

Fig. 436: Locating Catalyst Monitor Sensor (CMS) Electrical Connector
Courtesy of FORD MOTOR CO.

9. Position the transmission fluid cooler tubes in place and install the transmission fluid cooler tube bracket nut.
 - Tighten to 12 Nm (9 lb-ft).

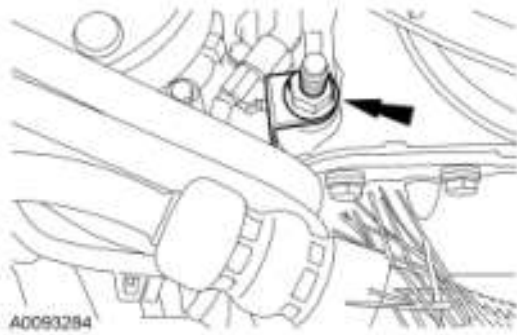

Fig. 437: Identifying Transmission Fluid Cooler Tube Bracket Nut
Courtesy of FORD MOTOR CO.

10. Connect the engine oil low level sensor electrical connector.

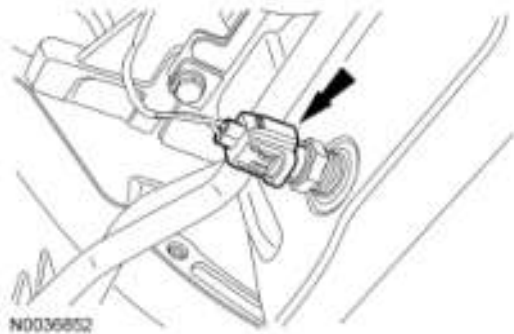

Fig. 438: Locating Oil Level Sensor Electrical Connector
Courtesy of FORD MOTOR CO.

NOTE: Inspect the case to make sure that the old O-rings are not stuck in the case.

NOTE: Install new O-rings on the ends of the cooler lines prior to installing.

11. Install new O-rings on the transmission fluid cooler tubes.

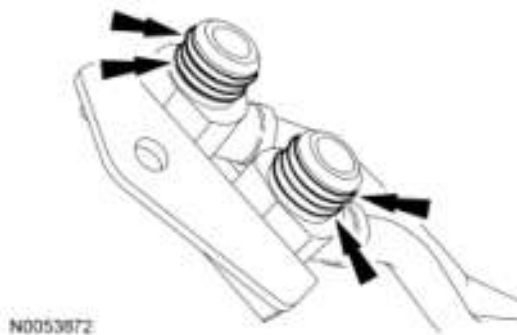

Fig. 439: Identifying Transmission Fluid Cooler Tube O-Rings
Courtesy of FORD MOTOR CO.

12. Install the transmission fluid cooler tube bracket bolt.
 - Tighten to 25 Nm (18 lb-ft).

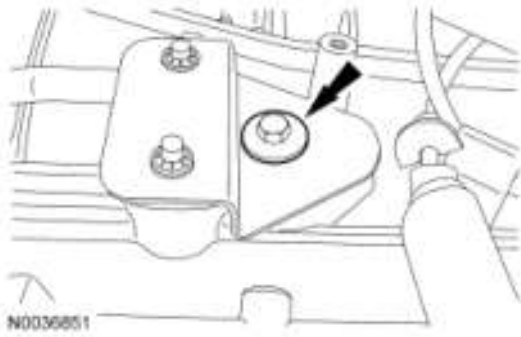

Fig. 440: Locating Transmission Cooler Tube Bracket Bolt
Courtesy of FORD MOTOR CO.

13. Install the starter motor and the 3 starter motor bolts.
 - Tighten to 26 Nm (19 lb-ft).



Fig. 441: Locating Starter Motor And Bolts
Courtesy of FORD MOTOR CO.

14. Install the ground wire on the stud and install the ground wire nut.
 - Tighten to 23 Nm (17 lb-ft).



Fig. 442: Locating Ground Wire Stud
Courtesy of FORD MOTOR CO.

15. Install the starter motor electrical connectors.
 1. Tighten to 12 Nm (9 lb-ft).
 2. Tighten to 6 Nm (53 lb-in).

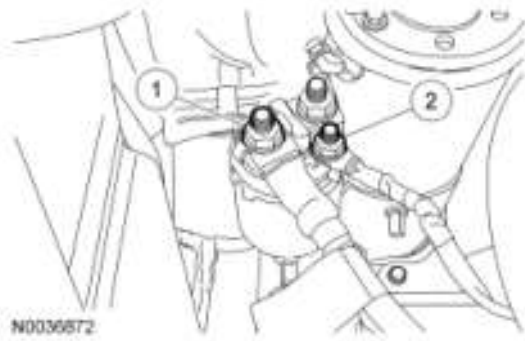

Fig. 443: Locating Starter Motor Electrical Connector Bolts
Courtesy of FORD MOTOR CO.

16. Install the plastic starter motor electrical connector cap.

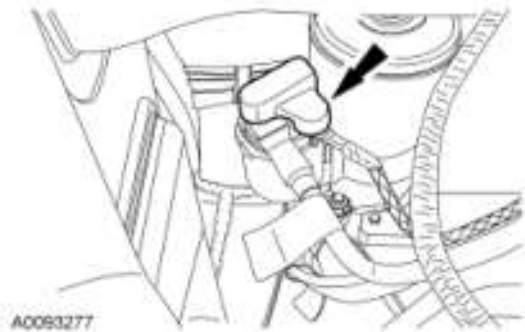

Fig. 444: Locating Plastic Starter Motor Electrical Connector Cap
Courtesy of FORD MOTOR CO.

17. Install 4 new torque converter nuts.
 - Tighten to 35 Nm (26 lb-ft).

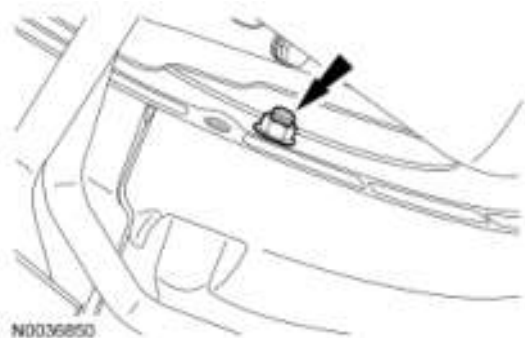
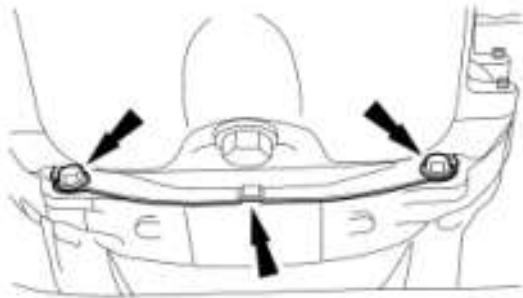

Fig. 445: Locating Flexplate-To-Torque Converter Nuts
Courtesy of FORD MOTOR CO.

18. Install the flexplate inspection cover and the inspection cover bolts.
 - Tighten to 35 Nm (26 lb-ft).



A0093275

Fig. 446: Locating Flexplate Inspection Cover Bolts
Courtesy of FORD MOTOR CO.

NOTE: When installing the selector lever cable, make sure that the selector lever cable locking tabs are locked in place and the selector lever cable end is snapped onto the ball stud. Press the selector lever cable into the bracket and listen for the selector lever cable to click into place. Pull back on the selector lever cable to make sure that it is locked into the selector lever cable bracket. Also, make sure that the selector lever cable end is correctly installed onto the ball stud. Pull back on the selector lever cable to make sure that the selector lever cable end is correctly installed.

19. Position the selector lever cable in place, install the selector lever cable bracket bolts and connect the selector lever cable end.
 - Tighten to 27 Nm (20 lb-ft).
 - Listen for the audible click.
 - Pull back on the selector lever cable to make sure that it is correctly installed.

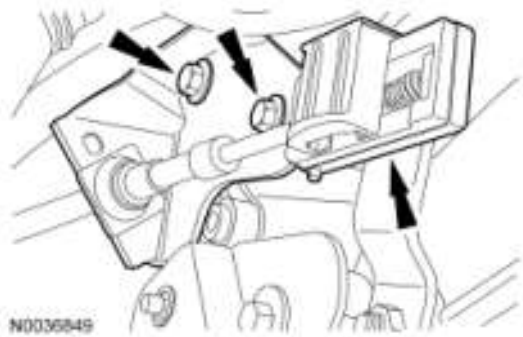

N0036849

Fig. 447: Locating Selector Lever Bracket And Bolts
Courtesy of FORD MOTOR CO.

20. Install selector lever cable shield.

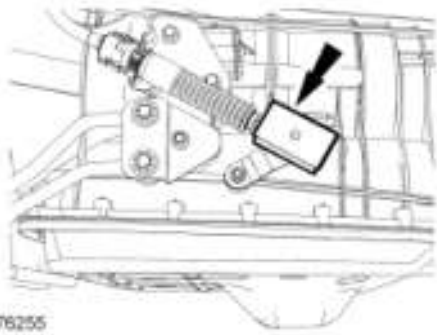

Fig. 448: Locating Selector Lever Cable Shield
Courtesy of FORD MOTOR CO.

21. Install the fuel line bracket bolt.
 - Tighten to 25 Nm (18 lb-ft).

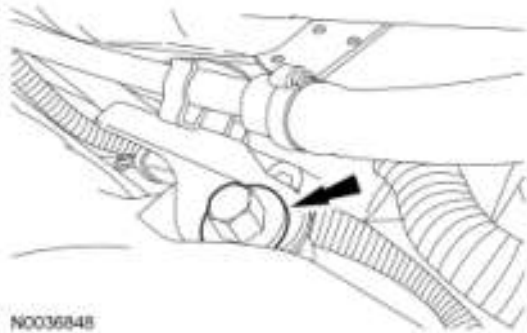

Fig. 449: Locating Fuel Line Bracket Bolt
Courtesy of FORD MOTOR CO.

22. Position the dual converter Y-pipe in place and install the dual converter Y-pipe bolts and new nuts.
 - Tighten to 40 Nm (30 lb-ft).

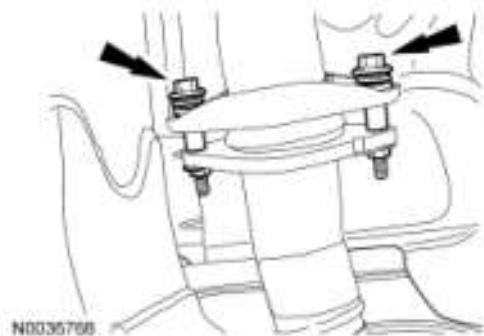

Fig. 450: Locating Dual Converter Y-Pipe Bolts
Courtesy of FORD MOTOR CO.

NOTE: LH shown, RH similar.

23. Install new LH and RH exhaust flange nuts.
 - Tighten to 40 Nm (30 lb-ft).

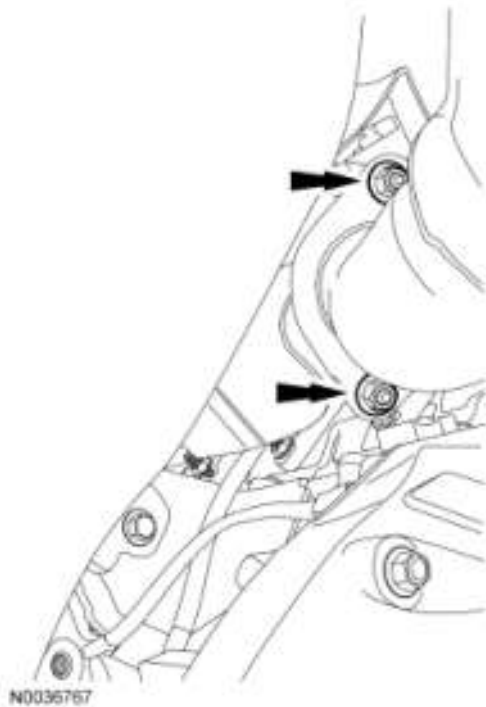

Fig. 451: Locating RH And LH Exhaust Flange Nuts
Courtesy of FORD MOTOR CO.

NOTE: LH shown, RH similar.

24. Connect the RH and LH heated oxygen sensors (HO2S) connectors and the catalyst monitor sensor electrical connectors.

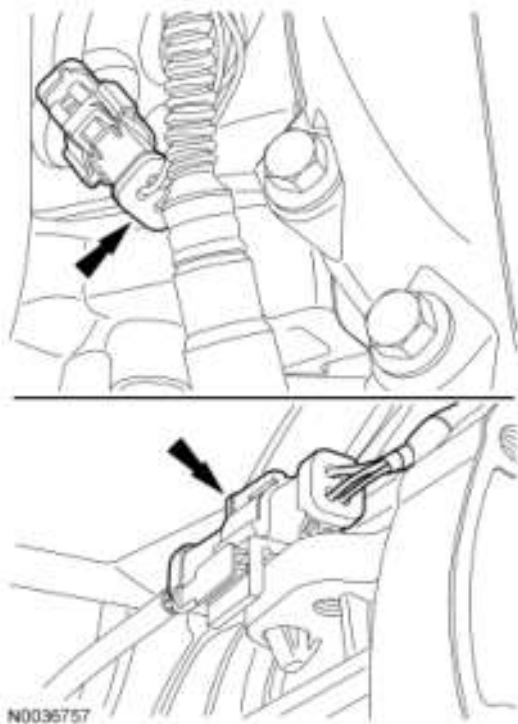

Fig. 452: Locating Heated Oxygen Sensors (HO2S) And Catalyst Monitor Sensor (CMS)

Electrical Connectors

Courtesy of FORD MOTOR CO.

25. Install the 4 RH side crossmember bolts and the nut.
- Tighten the vertical bolts to 80 Nm (59 lb-ft).
 - Tighten the horizontal nut to 90 Nm (66 lb-ft).

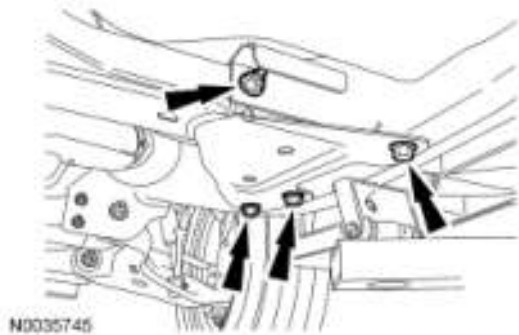

Fig. 453: Locating RH Side Crossmember Bolts And Nut
Courtesy of FORD MOTOR CO.

26. Install the 4 LH side crossmember bolts and the nut.
- Tighten the vertical bolts to 80 Nm (59 lb-ft).
 - Tighten the horizontal nut to 90 Nm (66 lb-ft).

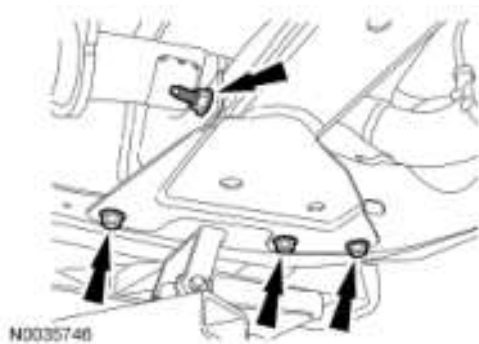

Fig. 454: Locating LH Side Crossmember Bolts And Nut
Courtesy of FORD MOTOR CO.

27. If equipped, install the RH exhaust heat shield.
- Tighten to 15 Nm (11 lb-ft).

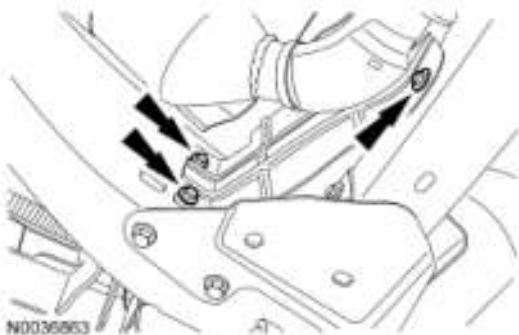

Fig. 455: Locating RH Exhaust Heat Shield Bolts
 Courtesy of FORD MOTOR CO.

28. Install the LH exhaust heat shield bolt.
 - Tighten to 15 Nm (11 lb-ft).



Fig. 456: Locating LH Heat Shield Bolt
 Courtesy of FORD MOTOR CO.

29. Install the transfer case. For additional information, refer to **TRANSFER CASE** .
30. Connect the battery ground cable. For additional information, refer to **BATTERY, MOUNTING AND CABLES** .
31. Verify that the selector lever cable is correctly adjusted. For additional information, refer to **AUTOMATIC TRANSAXLE/TRANSMISSION EXTERNAL CONTROLS** .
32. Reflash the transmission control module (TCM) to the latest level of software.
33. Using the transmission refill procedure, fill the transmission with clean transmission fluid. For additional information, refer to **Transmission Fluid Drain and Refill**.

TRANSMISSION - REAR WHEEL DRIVE (RWD)

Special Tools

Illustration	Tool Name	Tool Number
	Retainer, Torque Converter	307-346 (T97T-7902-A)

Material

Item	Specification
MERCON® SP Automatic Transmission Fluid XT-6-QSP (US); CXT-6-LSP12 (Canada)	MERCON® SP

INSTALLATION

1. Install the special tool.

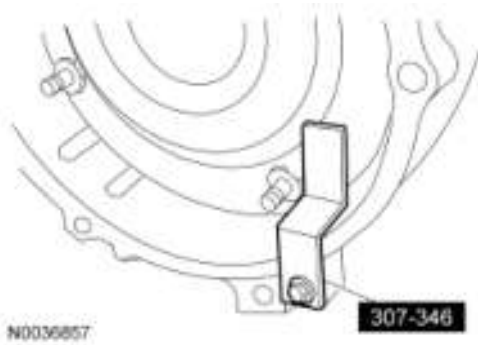

Fig. 457: Identifying Special Tool (307-346)
Courtesy of FORD MOTOR CO.

2. Install the transmission insulator bracket and the transmission insulator bracket bolts.
 - Tighten to 48 Nm (35 lb-ft).

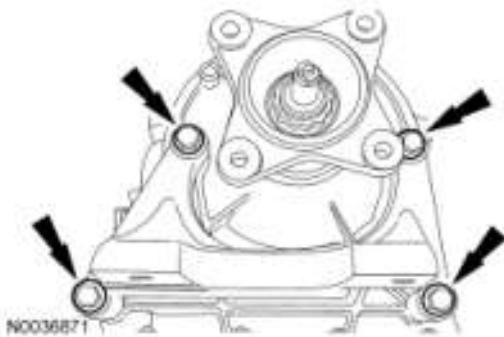

Fig. 458: Locating Transmission Mount Bracket Bolts
Courtesy of FORD MOTOR CO.

CAUTION: The converter housing is piloted into position by dowels in the rear of the engine block. The torque converter must rest squarely against the flexplate. This indicates that the converter pilot is not binding in the engine crankshaft.

3. Position and secure the transmission on the high-lift transmission jack. Raise and position the transmission into the vehicle.
4. Remove the special tool.

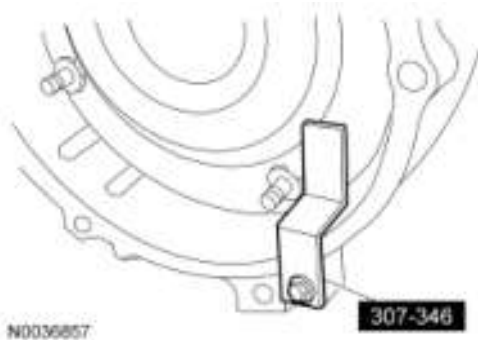

Fig. 459: Identifying Special Tool (307-346)
Courtesy of FORD MOTOR CO.

NOTE: Make sure the torque converter is fully seated in the transmission before aligning the transmission to the engine.

5. With the transmission in a horizontal position, move it toward the engine. Align the orange balancing marks between the torque converter studs and the flexplate bolt holes.

NOTE: Install the 7 transmission-to-engine bolts in their correct locations noted during removal.

NOTE: The top 2 transmission-to-engine bolts need to be installed prior to installing the rest of the bolts.

6. Install the 7 transmission-to-engine bolts.
 - Tighten to 48 Nm (35 lb-ft).

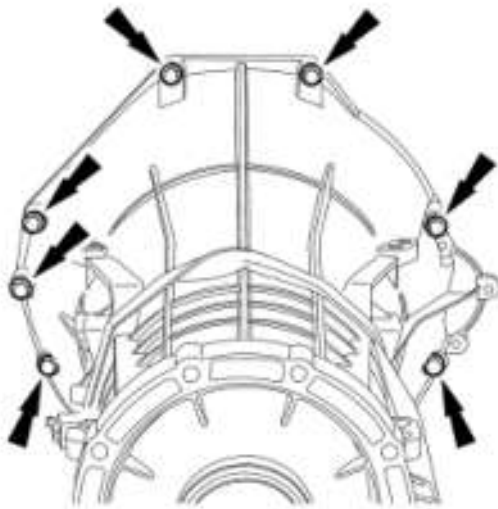

N0035865

Fig. 460: Locating Transmission-To-Engine Bolts
Courtesy of FORD MOTOR CO.

7. Connect the main transmission electrical harness by pushing it in and twisting the outer shell to lock it in place.

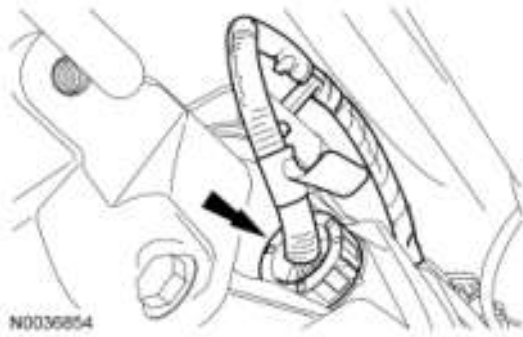

Fig. 461: Locating Main Transmission Electrical Harness
Courtesy of FORD MOTOR CO.

8. Connect the wire harness to the top of the transmission.



Fig. 462: Locating Wire Harness From Top Of Transmission
Courtesy of FORD MOTOR CO.

9. Install the catalyst monitor sensor electrical connector to the LH side of the transmission.

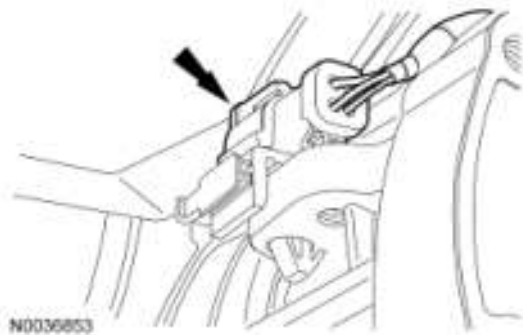

Fig. 463: Locating Catalyst Monitor Sensor (CMS) Electrical Connector
Courtesy of FORD MOTOR CO.

10. Position the dual converter Y-pipe in place and install the 2 dual converter Y-pipe bolts and new nuts.
 - Tighten to 40 Nm (30 lb-ft).

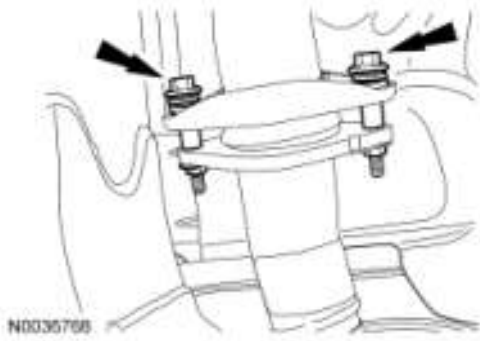

Fig. 464: Locating Dual Converter Y-Pipe Bolts
Courtesy of FORD MOTOR CO.

NOTE: LH shown, RH similar.

11. Install new LH and RH exhaust flange nuts.
 - Tighten to 40 Nm (30 lb-ft).

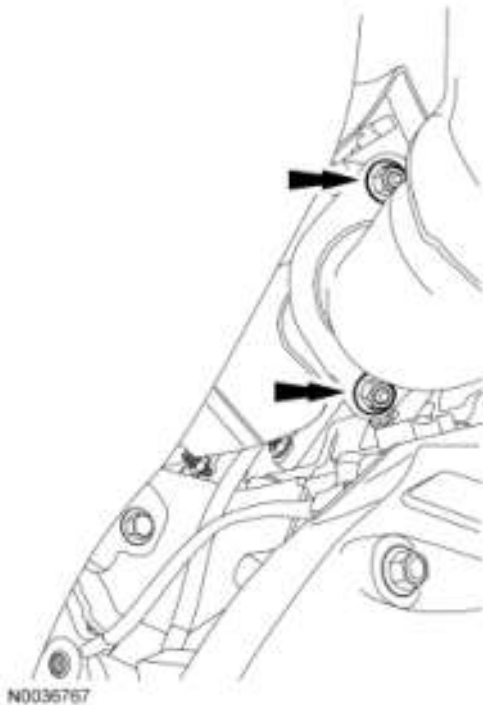

Fig. 465: Locating RH And LH Exhaust Flange Nuts
Courtesy of FORD MOTOR CO.

NOTE: LH shown, RH similar.

12. Connect the RH and LH heated oxygen sensors (HO2S) electrical connectors and the catalyst monitor sensor electrical connectors.

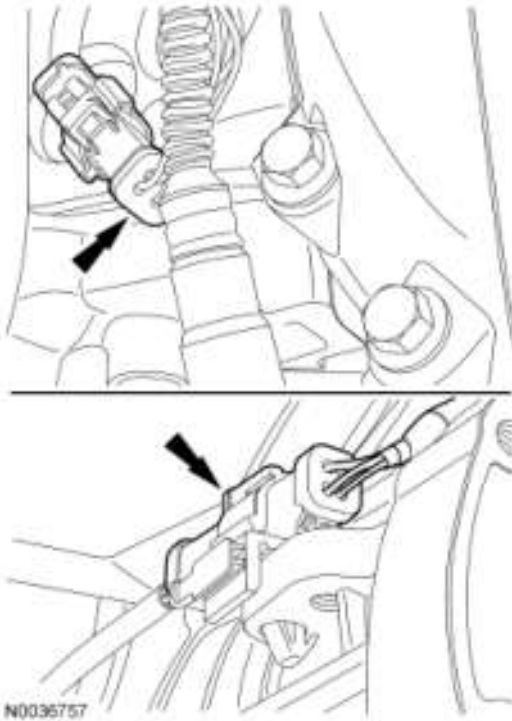

Fig. 466: Locating Heated Oxygen Sensors (HO2S) And Catalyst Monitor Sensor (CMS) Electrical Connectors
Courtesy of FORD MOTOR CO.

13. Position the transmission insulator in place and install the 2 transmission insulator bolts.
 - Tighten to 80 Nm (59 lb-ft).

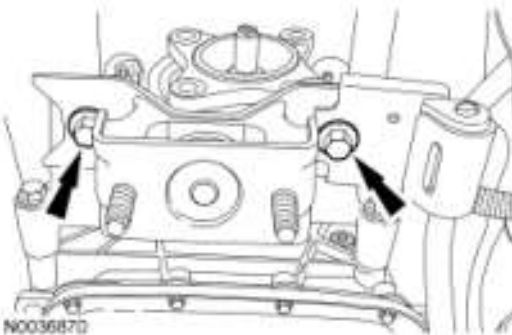

Fig. 467: Locating Transmission Insulator Bolts
Courtesy of FORD MOTOR CO.

14. Position the rear crossmember in place and loosely install the transmission insulator nuts.

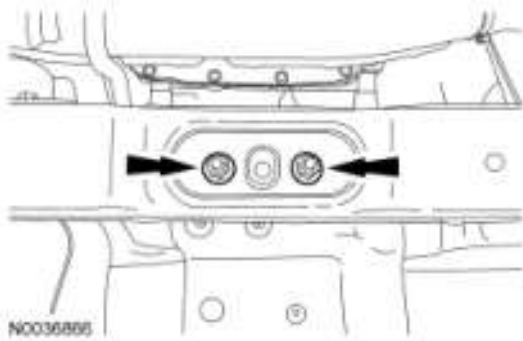

Fig. 468: Locating Rear Crossmember Nuts And Crossmember
Courtesy of FORD MOTOR CO.

15. Install the 8 crossmember bolts.
 1. Tighten to 80 Nm (59 lb-ft).
 2. Tighten to 90 Nm (66 lb-ft).



Fig. 469: Identifying Crossmember Bolts
Courtesy of FORD MOTOR CO.

16. Tighten the transmission insulator nuts.
 - Tighten to 103 Nm (76 lb-ft).

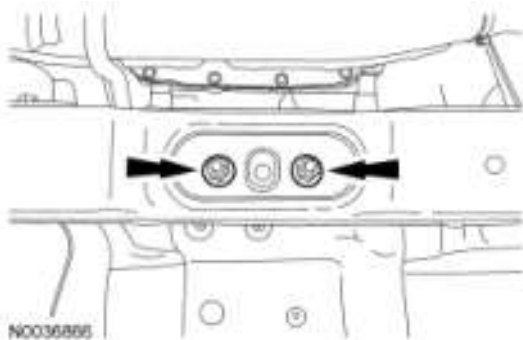

Fig. 470: Locating Rear Crossmember Nuts And Crossmember
Courtesy of FORD MOTOR CO.

17. Install the LH exhaust heat shield bolt.
 - Tighten to 15 Nm (11 lb-ft).

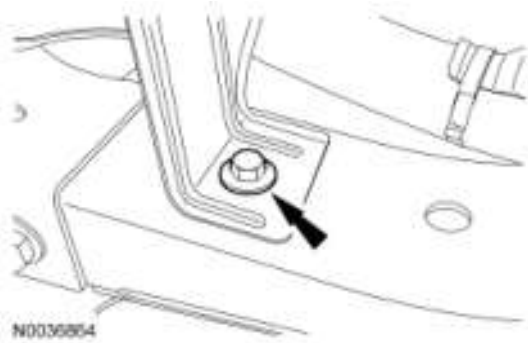

Fig. 471: Locating LH Exhaust Heat Shield Bolt
Courtesy of FORD MOTOR CO.

18. If equipped, install the RH exhaust heat shield.
 - Tighten to 15 Nm (11 lb-ft).

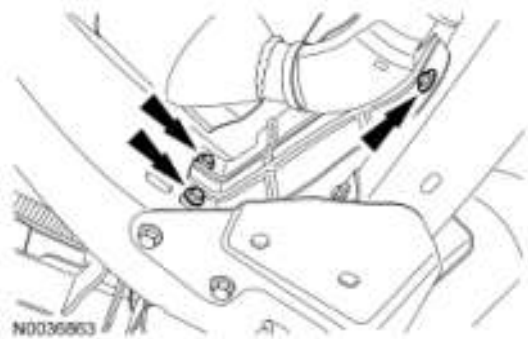

Fig. 472: Locating RH Exhaust Heat Shield Bolts
Courtesy of FORD MOTOR CO.

19. Position the transmission fluid cooler tubes in place and install the transmission fluid cooler tube bracket nut.
 - Tighten to 12 Nm (9 lb-ft).

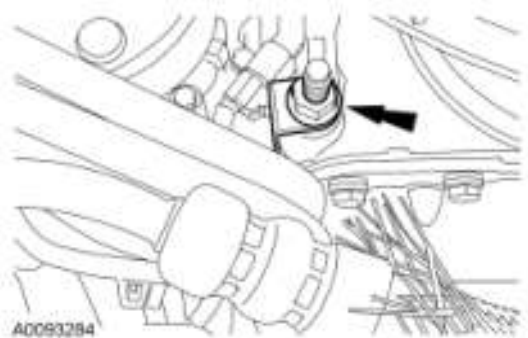

Fig. 473: Identifying Transmission Fluid Cooler Tube Bracket Nut
Courtesy of FORD MOTOR CO.

20. Connect the engine oil low level sensor electrical connector.

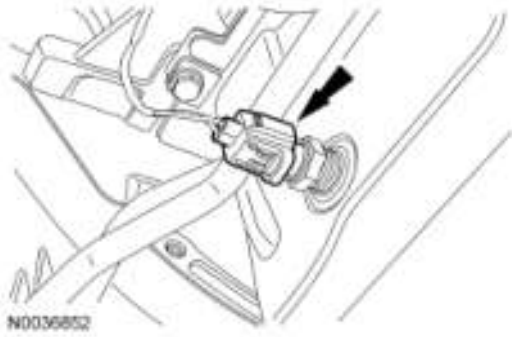

Fig. 474: Locating Oil Level Sensor Electrical Connector
Courtesy of FORD MOTOR CO.

NOTE: Inspect the case to make sure that the old O-rings are not stuck in the case.

NOTE: Install new O-rings on the ends of the cooler lines prior to installing.

21. Install new O-rings on the transmission fluid cooler tubes.

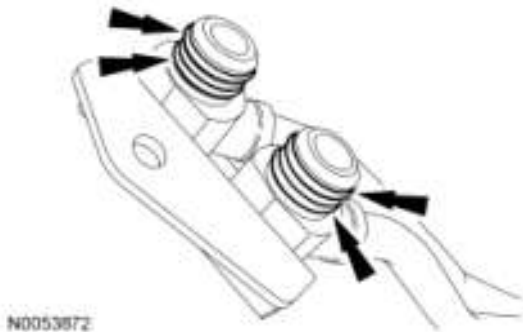

Fig. 475: Transmission Fluid Cooler Tube O-Rings
Courtesy of FORD MOTOR CO.

22. Install the transmission cooler tube bracket bolt.
- Tighten to 25 Nm (18 lb-ft).

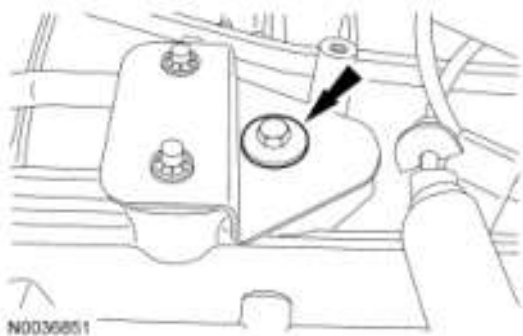

Fig. 476: Locating Transmission Cooler Tube Bracket Bolt
Courtesy of FORD MOTOR CO.

23. Position the starter motor in place and install the 3 starter motor bolts.

- Tighten to 26 Nm (19 lb-ft).

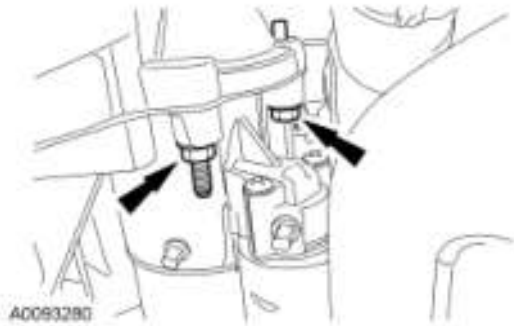

Fig. 477: Locating Starter Motor And Bolts
Courtesy of FORD MOTOR CO.

24. Install the ground wire on the stud and install the ground wire nut.
 - Tighten to 23 Nm (17 lb-ft).



Fig. 478: Locating Ground Wire Stud
Courtesy of FORD MOTOR CO.

25. Install the starter motor electrical connectors.
 1. Tighten to 12 Nm (9 lb-ft).
 2. Tighten to 6 Nm (53 lb-in).

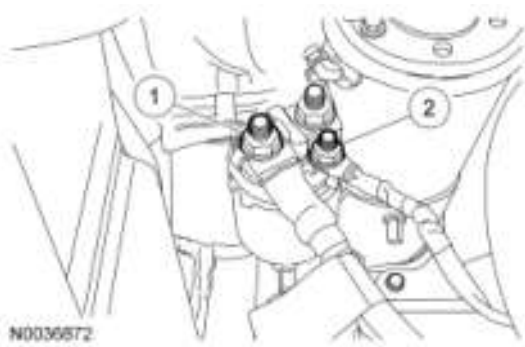

Fig. 479: Locating Starter Motor Electrical Connector Bolts
Courtesy of FORD MOTOR CO.

26. Install the plastic starter motor electrical connector cap.

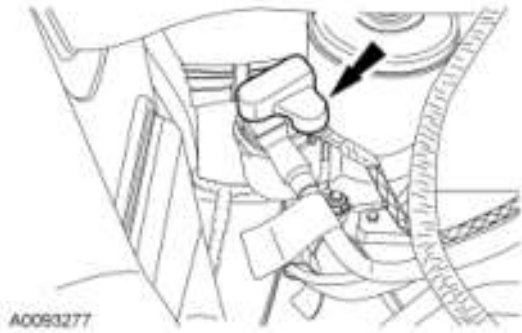

Fig. 480: Locating Plastic Starter Motor Electrical Connector Cap
Courtesy of FORD MOTOR CO.

27. Install 4 new flexplate-to-torque converter nuts.
 - Tighten to 35 Nm (26 lb-ft).

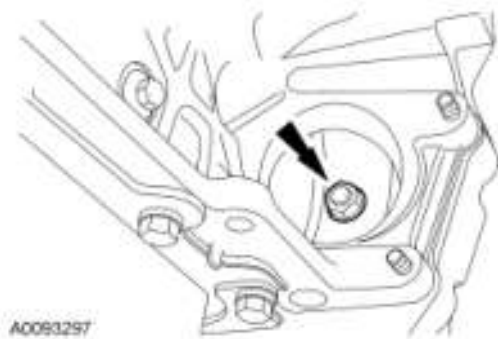

Fig. 481: Locating Flexplate-To-Torque Converter Nuts
Courtesy of FORD MOTOR CO.

28. Install the rubber access plug.

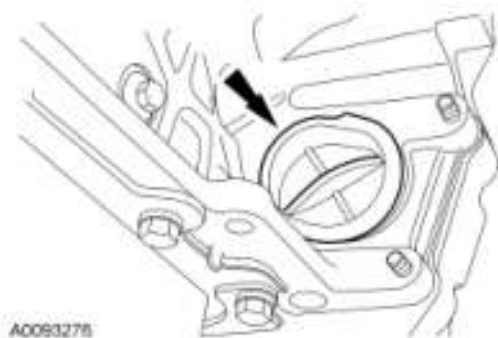
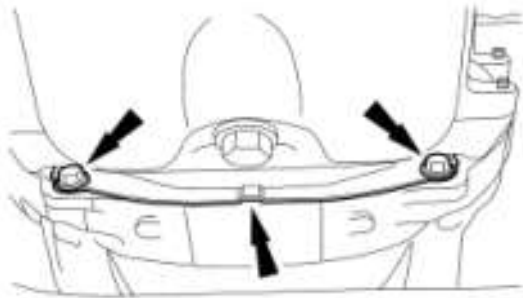

Fig. 482: Locating Rubber Torque Converter Nut Access Plug
Courtesy of FORD MOTOR CO.

29. Install the flexplate inspection cover and the flexplate inspection cover bolts.
 - Tighten to 35 Nm (26 lb-ft).



A0093275

Fig. 483: Locating Flexplate Inspection Cover Bolts
Courtesy of FORD MOTOR CO.

NOTE: When installing the selector lever cable, make sure that the selector lever cable locking tabs are locked in place and the selector lever cable end is snapped onto the ball stud. Press the selector lever cable into the bracket and listen for the selector lever cable to click into place. Pull back on the selector lever cable to make sure that it is locked into the selector lever cable bracket. Also, make sure that the selector lever cable end is correctly installed onto the ball stud. Pull back on the selector lever cable to make sure that the selector lever cable end is correctly installed.

30. Position the selector lever cable in place, install the selector lever cable bracket bolts and connect the selector lever cable end.
 - Tighten to 27 Nm (20 lb-ft).
 - Listen for the audible click.
 - Pull back on the selector lever cable to make sure that it is correctly installed.

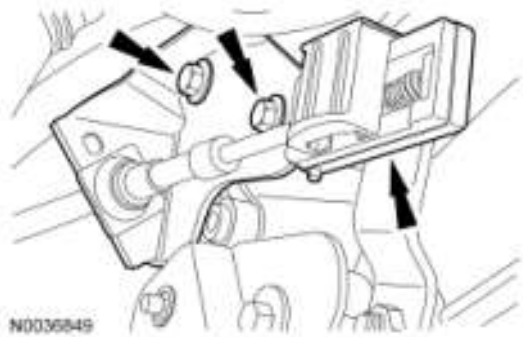

N0036849

Fig. 484: Locating Selector Lever Bracket And Bolts
Courtesy of FORD MOTOR CO.

31. Install the selector lever cable shield.

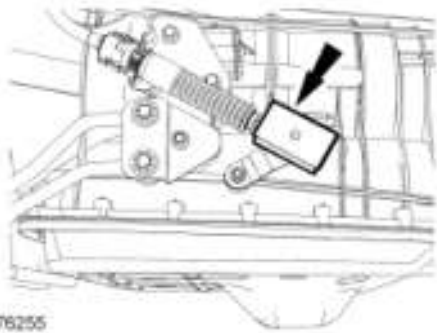

Fig. 485: Identifying Selector Lever Cable Shield
Courtesy of FORD MOTOR CO.

32. Position the fuel line in place and install the bolt.
 - Tighten to 25 Nm (18 lb-ft).

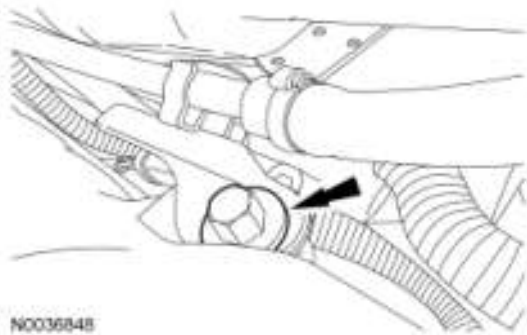

Fig. 486: Locating Fuel Line Bracket Bolt
Courtesy of FORD MOTOR CO.

33. Install the driveshaft. For additional information, refer to **DRIVESHAFT** .
34. Connect the battery ground cable. For additional information, refer to **BATTERY, MOUNTING AND CABLES** .
35. Verify that the selector lever cable is correctly adjusted. For additional information, refer to **AUTOMATIC TRANSAXLE/TRANSMISSION EXTERNAL CONTROLS** .
36. Reflash the transmission control module (TCM) to the latest level of software.
37. Using the transmission fluid refill procedure, fill the transmission with clean automatic transmission fluid. For additional information, refer to **Transmission Fluid Drain and Refill**.