

TESTING

NOTE: Following test procedures only apply to models equipped with Electronic Shift Transfer Case.

ELECTRONIC SHIFT TRANSFER CASE

Circuit Protection

The battery feed circuit, through a circuit breaker, provides memory capability for the electronic control module. Ignition "RUN", and "ACC" circuits, through a fuse, supply power for switches and electric shift motor. The side marker lamp circuit supplies power for illumination of overhead console.

Control Module Self-Test

1. To perform electronic control module self-test, remove the 5-wire connector and the 8-wire connector from the module. Turn ignition switch to "RUN" position. See **Fig. 2**.
2. Activate the self-test switch and note result. A flashing indicator lamp indicates control module is okay. A steady indicator light indicates control module is inoperative and must be replaced.

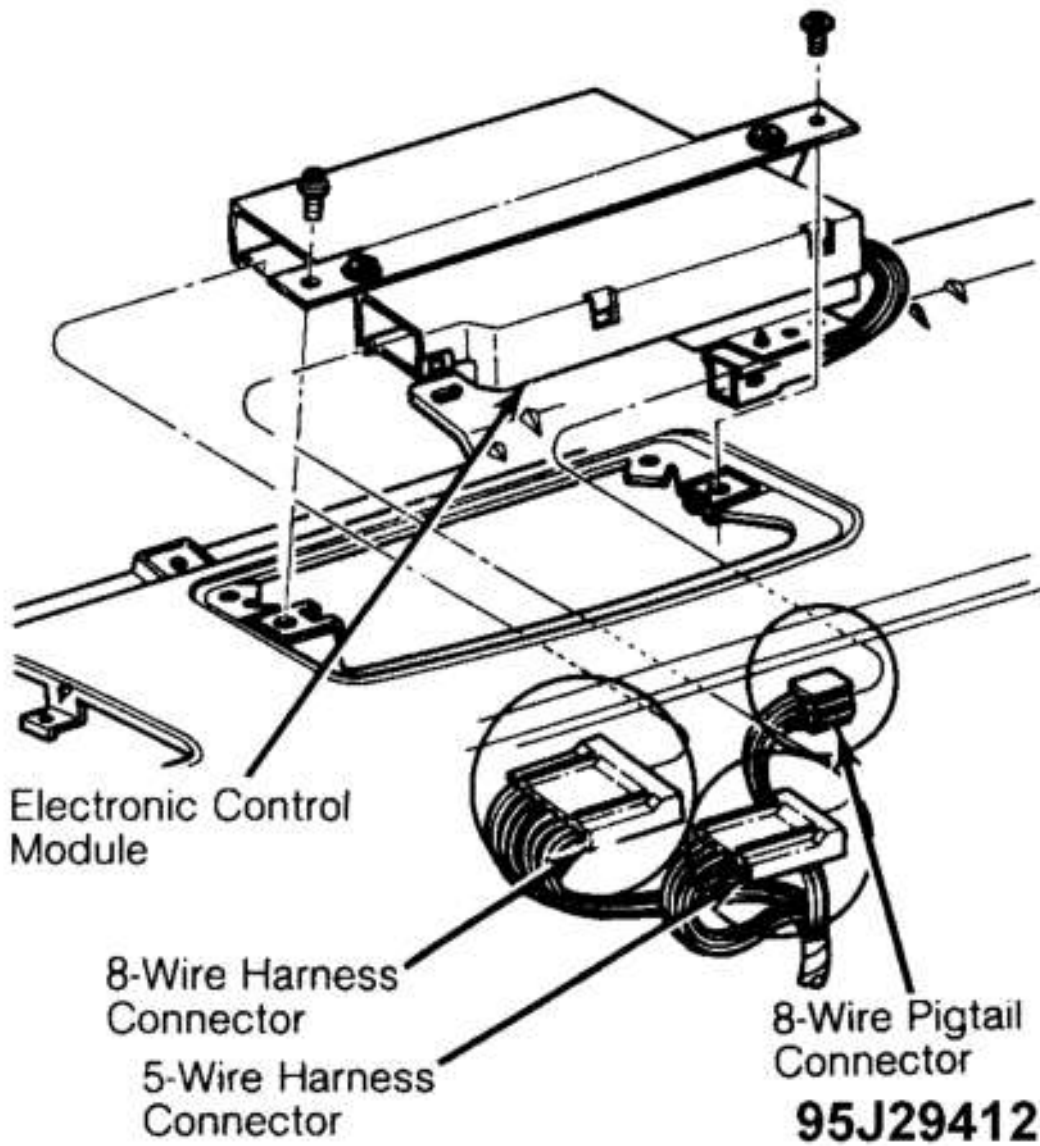
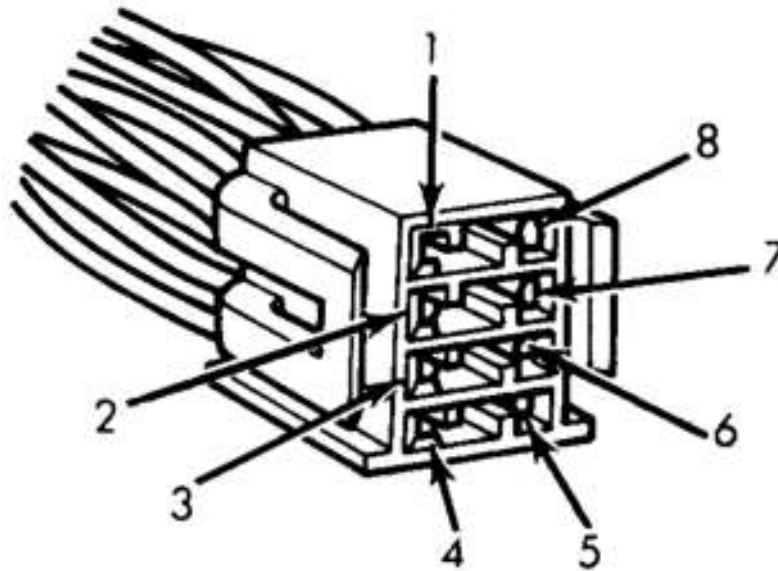

Fig. 2: Electronic Control Module
Courtesy of FORD MOTOR CO.

8-Wire Pigtail Connector Test

1. With ignition off, unplug 8-wire connector from module. Connect voltmeter between terminal No. 8 and ground. Battery voltage should be present at all times. See **Fig. 3**.
2. Connect voltmeter between terminal No. 7 and ground. Turn ignition to "RUN" position. Battery voltage should be present.



Position	Circuit Number	Color Code	Function
1	OPEN		
2	57	Blk	Ground
	57A	Blk	Ground
3	396	Blk/Org	Logic Ground
4	778	Org	Transfer Case Motor Control (Clockwise) 2H-4H-4L
5	777	Yel	Transfer Case Motor Control (Counterclockwise) 4L-4H-2H
6	779	Brn	Electro-Magnetic Clutch (Feed)
7	296	Wht/Ppl	Ignition Run and Accessory Feed (Fused)
8	517	Blk/Wht	Battery Feed (Circuit Breaker)

95A29413

Fig. 3: 8-Wire Pigtail Connector & Function Chart
 Courtesy of FORD MOTOR CO.

CAUTION: Turn off ignition before proceeding with ohmmeter tests. Never connect voltmeter to powered circuit.

3. Connect ohmmeter between terminal No. 6 and ground. There should be less than 10 ohms present. Connect ohmmeter between terminals No. 4 and 5 of connector. Resistance should be less than 10 ohms.
4. Connect ohmmeter between terminal 3 and ground. There should be zero ohms. Resistance between terminal 2 and ground should be zero ohms.

5-Wire Connector Test

1. Connect ohmmeter between terminals No. 1 and 2. Depress "2H-4H" switch in overhead console. Resistance should be less than 50 ohms while switch is depressed. See **Fig. 4**.
2. Connect ohmmeter between terminals No. 1 and 3. Depress "LOW RANGE" switch in overhead console. Resistance should be less than 50 ohms with switch depressed.

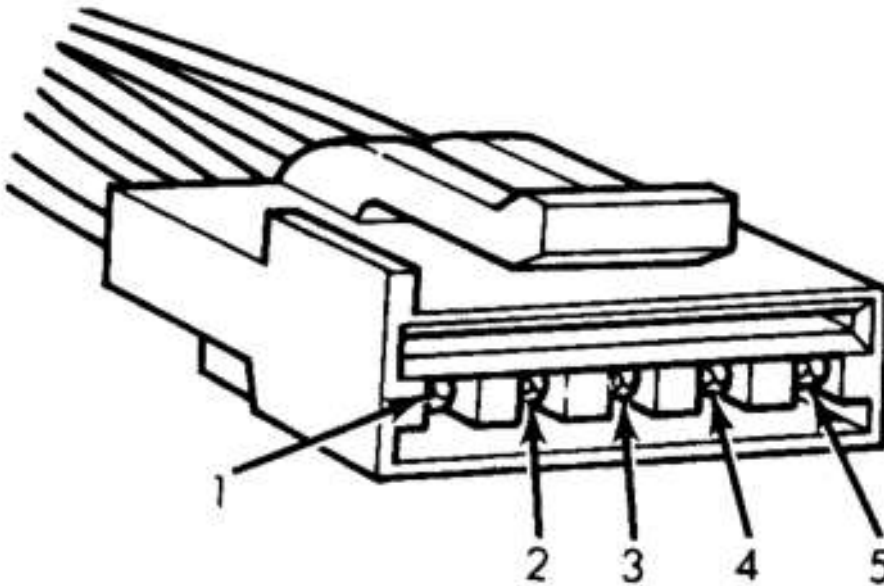

Position	Circuit Number	Color Code	Function
1	465	Wht/Lt Blu	Switch Feed
2	780	Dk Blu	Low Range Switch
3	781	Org/Lt Blu	Ground
4	782	Brn/Wht	Low Range Light
5	783	Gry	4x4 Light

95B29414

Fig. 4: 5-Wire Harness Connector & Function Chart
 Courtesy of FORD MOTOR CO.

3. Connect jumper wire between terminal No. 4 and ground. Turn ignition switch to "RUN" position. Light in overhead console low range bar should illuminate. Turn ignition off and remove jumper wire.
4. Connect jumper wire between terminal No. 5 and ground. Turn ignition to "RUN" position. The "4 x 4" bar should illuminate on overhead console.

8-Wire Harness Connector Test

1. Turn ignition off. Connect ohmmeter between terminals No. 1 and ground. On manual transmission, depress clutch pedal and observe ohmmeter. There should be less than 50 ohms.
2. On automatic transmission, shift transmission into Neutral and observe ohmmeter. There should be less than 50 ohms.
3. Measure resistance between terminals No. 2 and 3. There should be 200-300 ohms. This checks speed sensor continuity.
4. Connect ohmmeter between terminal No. 8 and, in turn, terminals No. 4, 5, 6 and 7. Resistance should be as specified. See **Fig. 5**.

Position	Circuit Number	Color Code	Function
1	32	Red/Lt Blu	Manual Transmission Clutch Interlock Switch
	463	Red/WH	Automatic Transmission Neutral Safety Switch
2	774	Lt Grn	Speed Sensor (Feed)
3	772	Lt Blu	Speed Sensor Return
4	771	Violet	Wire #5, Contact Plate Position Sensor in Transfer Case
5	770	Whi	Wire #4, Contact Plate Position Sensor in Transfer Case
6	764	Brn/Whi	Wire #3, Contact Plate Position Sensor in Transfer Case
7	763	Org/Whi	Wire #2, Contact Plate Position Sensor in Transfer Case
8	762	Yel/Whi	Wire #1, Contact Plate Position Sensor in Transfer Case

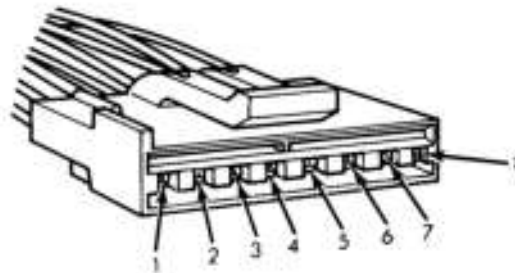

OHMMETER READINGS FOR SHIFT MOTOR POSITION SENSOR

Ohmmeter Connection	Transfer Case Gear Position		
	2 High	4 High	4 Low
Meter Reading From Terminal #8 to #4	Short	Open	Short
Meter Reading From Terminal #8 to #5	Open	Open	Short
Meter Reading From Terminal #8 to #6	Short	Short	Open
Meter Reading From Terminal #8 to #7	Open	Short	Open

NOTE: SHORT is a "low" resistance reading on the ohmmeter (zero ohms).
 OPEN is a "high" resistance reading on the ohmmeter (infinity).

95C29415

Fig. 5: 8-Wire Harness Connector & Function Charts
 Courtesy of FORD MOTOR CO.

Main Feed Connector

1. Main feed connector is located near middle of instrument panel. See **Fig. 7**.

10-Pin Connector

For functions of 10-pin connector, See **Fig. 6**.

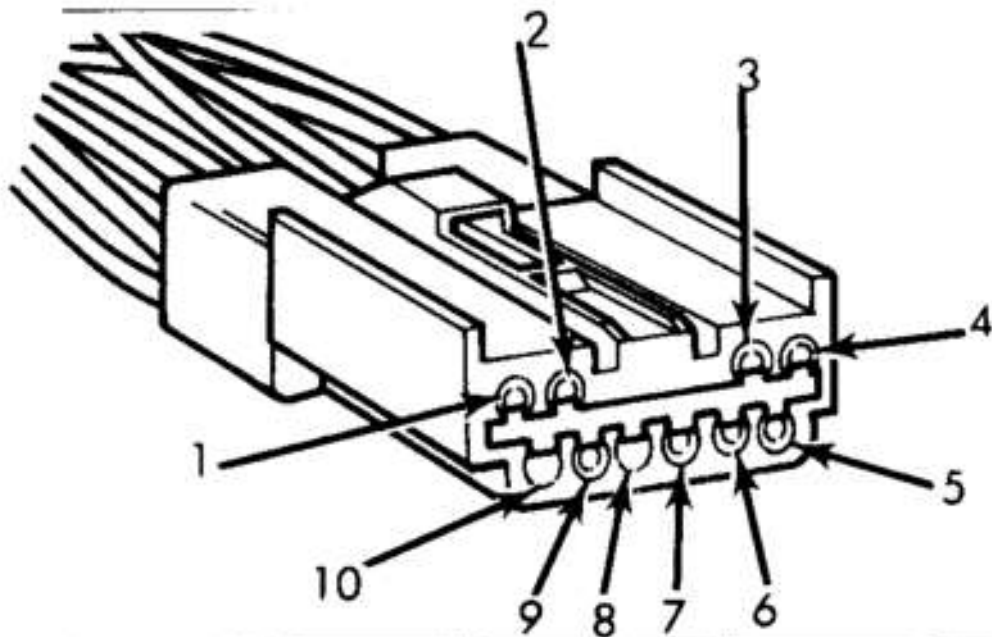

Position	Circuit Number	Color Code	Function
1	465	Wht/Lt Blu	Switch Enable Feed
2	780	Dk Blu	4x4 Switch
3	57B	Blk	Ground
4	19	Lt Blu/Red	Side Marker Lamp (Feed)
5	783	Gry	4x4 Light
6	781	Org/Lt Blu	Low Range Switch
7	640	Red/Yel	Ignition Run and Accessory Feed (Fused)
8	OPEN		
9	782	Brn/Wht	Low Range Light
10	OPEN		

95D29416

Fig. 6: 10-Pin Connector Harness & Function Chart
 Courtesy of FORD MOTOR CO.

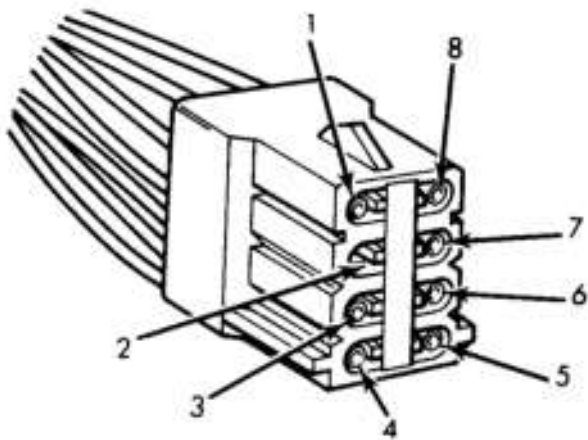

Position	Circuit Number	Color Code	Function
1	640	Red/Yel	Ignition Run and Accessory Feed (Fused)
2 (Used Only on Auto Trans)	463	Red/Wht	Automatic Transmission Neutral Safety Switch
3	296	Wht/Ppl	Ignition Run and Accessory Feed (Fused)
4	57	Blk	Ground
5	19	Lt Blu/Red	Side Marker Lamp (Feed)
6	54	Lt Grn/Yel	Dome Lamp (Feed)
7 (Used Only on Manual Trans)	32	Red/Lt Blu	Manual Transmission Clutch Interlock Switch
8	517	Blk/Wht	Battery Feed (Circuit Breaker)

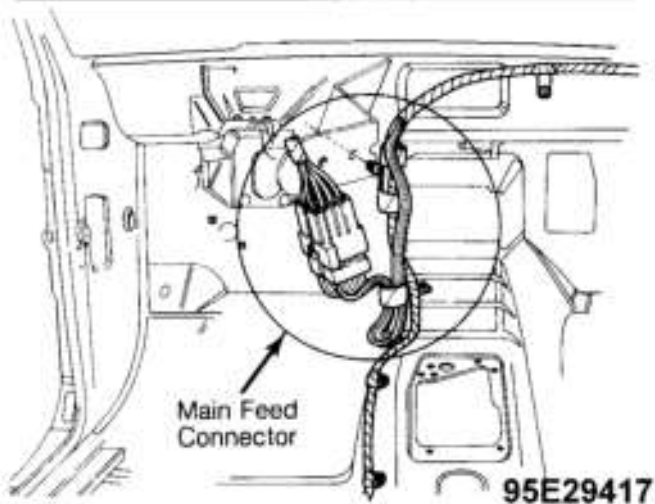
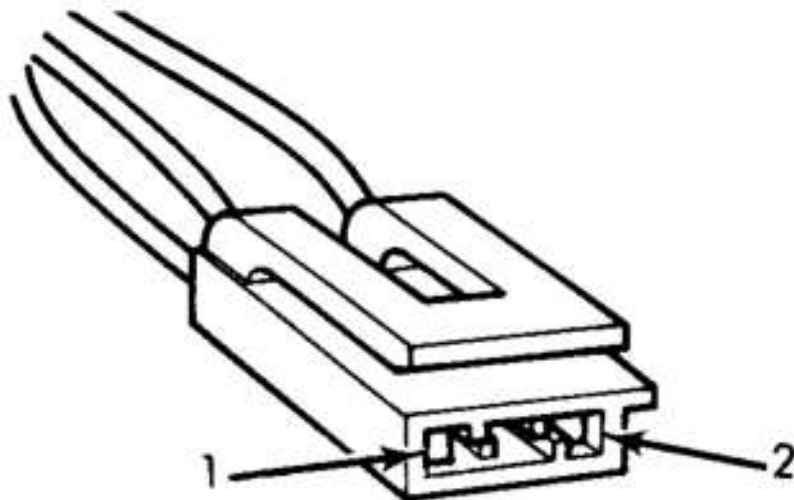

Fig. 7: Main Feed Connector
 Courtesy of FORD MOTOR CO.

2-Pin Connector

For functions of 10-pin connector, See **Fig. 8**.



Position	Circuit Number	Color Code	Function
1	57A	Blk	Ground
	57B	Blk	Ground
2	54	Lt Grn/Yel	Dome Lamp (Feed)

95G24919

Fig. 8: 2-Pin Connector Harness & Function Chart
 Courtesy of FORD MOTOR CO.

Electronic Transfer Case Feed

For functions of transfer case feed, See **Fig. 9** .

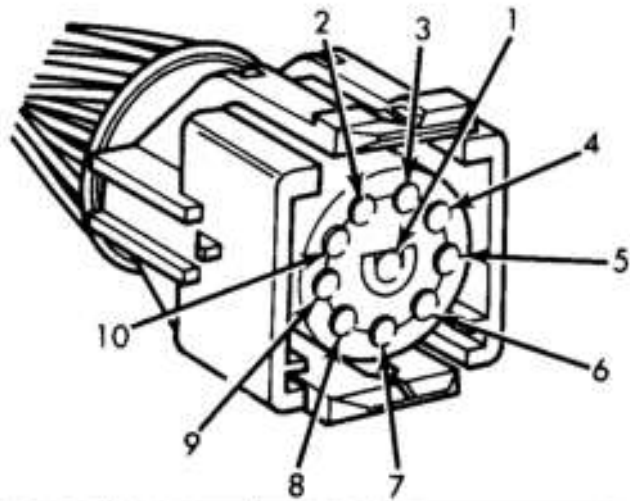

Position	Circuit Number	Color Code	Function
1	779	Brn	Electro-Magnetic Clutch (Feed)
2	778	Org	Transfer Case Motor Control (Clockwise) 2H-4H-4L
3	777	Yel	Transfer Case Motor Control (Counterclockwise) 4L-4H-2H
4	774	Lt Grn	Speed Sensor (Feed)
5	772	Lt Blu	Speed Sensor (Return)
6	771	Violet	Wire #5, Shift Position Sensor in Transfer Case (Output to Module)
7	770	Wht	Wire #4, Shift Position Sensor in Transfer Case (Output to Module)
8	764	Brn/Wht	Wire #3, Shift Position Sensor in Transfer Case (Output to Module)
9	763	Org/Wht	Wire #2, Shift Position Sensor in Transfer Case (Output to Module)
10	762	Yel/Wht	Wire #1, Shift Position Sensor in Transfer Case (Input from Module)

95F29418

Fig. 9: Electronic Transfer Case Feed
 Courtesy of FORD MOTOR CO.

Shift Motor Function

Attach voltmeter to A4 and A5. Have an assistant change shift positions. Voltage should increase for about 1 second and relay should click. If voltage is present, remove shift motor from transfer case and initiate another shift. Motor should rotate, replace motor if it does not rotate. If voltage is not present to motor, check power circuits and range sensors.

NOTE: If transfer case range sensors are providing incorrect data, control module will not power motor.

Shift Motor Chatters, But Will Not Shift

During a shift from 2H to 4H, motor chatters or clicks but does not shift. Motor may hunt to find 4H and overshoot, then hunt back and overshoot again. After 7-10 seconds, module returns shift motor to 2H (default). If shift motor is running too fast or braking too slowly for proper positioning, it must be replaced.

SHIFT MOTOR POSITION

Motor Position	Dash & Switch Lights	Mech Position	B7 (1)	B6 (1)	B5 (1)	(1) B4
2H	No	2H	Open	Closed	Open	Closed
Edge 1	No	2H	Closed	Closed	Open	Closed
2H-4H	No	2H	Closed	Open	Open	Closed
Edge 2 (2)	No	4H	Closed	Closed	Open	Closed
4H	4H On	4H	Closed	Closed	Open	Open
Edge 3 (3)	4H On	4H	Closed	Closed -	Closed	Open
4H-4L	4H On	Neutral	Open	Closed	Closed	Open
Edge 4 (3)	4H On	4L	Open	Closed	Closed	Closed
4L	4H & 4L On	4L	Open	Open	Closed	Closed

(1) Three or more open readings in any position indicates a fault with motor and sensor assembly.

(2) In Edge 2, pressing 4H switch moves to 4H position and light comes on.

(3) If motor is in Edge 3, 4H-4L or Edge 4 at start up, control module will attempt shift to 4H. 4H shift requires that vehicle is stopped, clutched depressed or A/T in Neutral. Until these conditions are met and shift is completed, pushing buttons will not do anything.