

TRANSMISSION REASSEMBLY

1. Install countershaft, input shaft and output shaft assemblies into transmission case through top opening. See **Fig. 14**.

NOTE: Ensure that needle roller bearing is installed into input shaft and 4th gear synchronizer ring is installed at this time.

2. Mate input and output shaft assemblies by positioning them at an upward angle and setting them together. Install output shaft center bearing outer race using a brass drift. Seat center bearing outer races. Install countershaft center bearing. Ensure center bearing outer races are squarely positioned in bores.

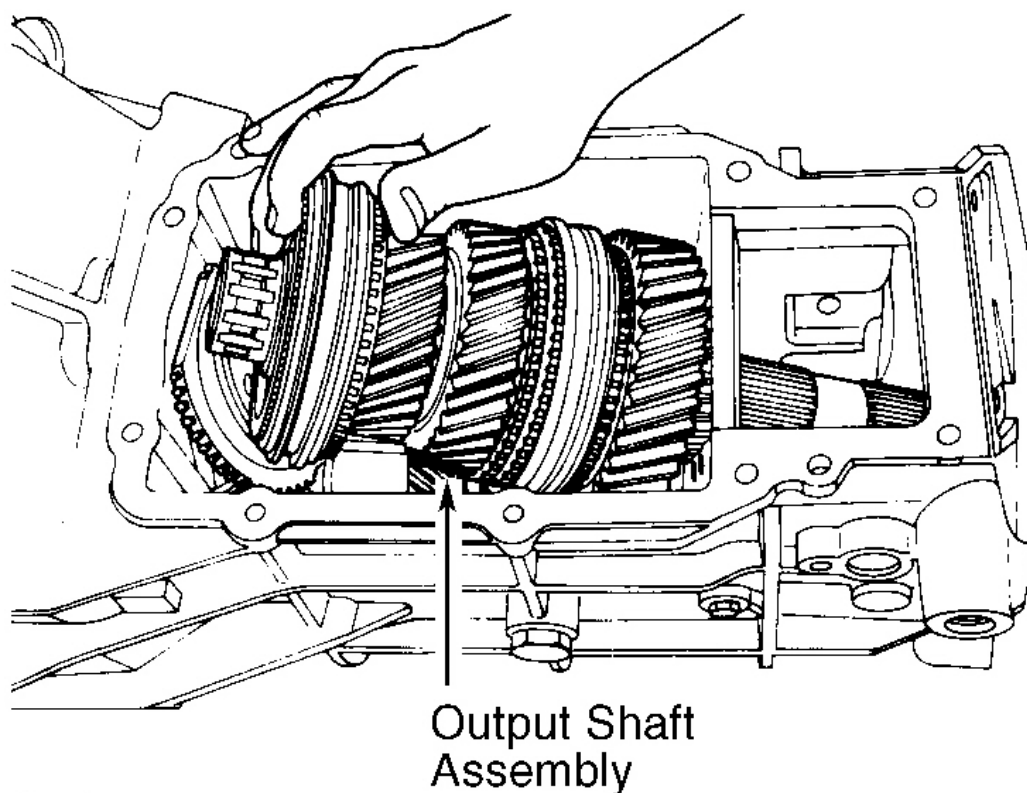

G92G13892

Fig. 14: Installing Output Shaft
Courtesy of FORD MOTOR CO.

3. Position center bearing cover to transmission case with reference arrow pointing upward. Ensure all center bearing cover bolt heads are marked with an "8". Tighten center bearing cover bolts to specification. See **TORQUE SPECIFICATIONS** table at end of article.

NOTE: If any input shaft, output shaft or countershaft related components are replaced, end play must be readjusted. See **INPUT SHAFT END PLAY**.

4. Install countershaft front bearing by hand. Apply grease to shim, bearing cover and oil baffle to retain them in position during assembly. Install shim with groove showing. Install spacer to transmission case countershaft front bearing bore.
5. Install Woodruff key or lock ball, 5th gear sleeve and 5th gear needle bearing onto 5th gear countershaft. To install 5th gear assembly, use Gear Installing Spacer (T88T-7025-F). When tool bottoms, add Gear Installing Spacer (T88T-7025-G) and press 5th gear assembly all the way into position.
6. Position counter lever assembly on transmission and install thrust washer and retaining ring. If removed, position 5th-reverse shift fork and shift rail to top cover. See **Fig. 15**. Insert 5th-reverse shift rail through top cover bore and 5th-reverse shift fork. Install spring and detent ball to lower part of rod.

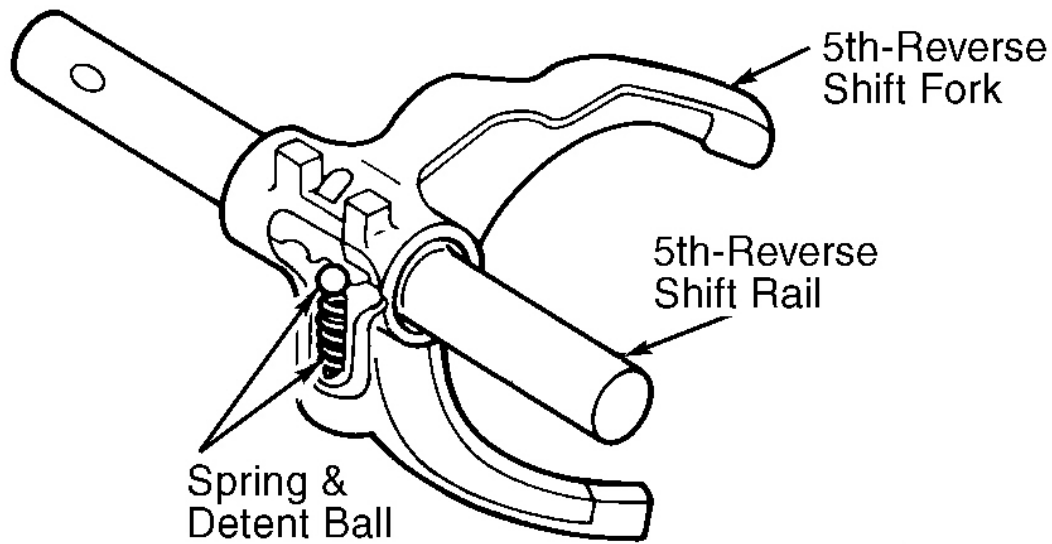

G92H13893

Fig. 15: Installing 5th-Reverse Shift Fork & Rail

Courtesy of FORD MOTOR CO.

7. Assemble 5th-reverse synchronizer hub, sleeve and 5th gear synchronizer ring to 5th-reverse shift fork and rod assembly.
8. Install longer flange, on 5th-reverse hub, sleeve and synchronizer assembly, toward front of transmission. Reference mark on synchronizer sleeve must be installed toward reverse gear. See **Fig. 16**.

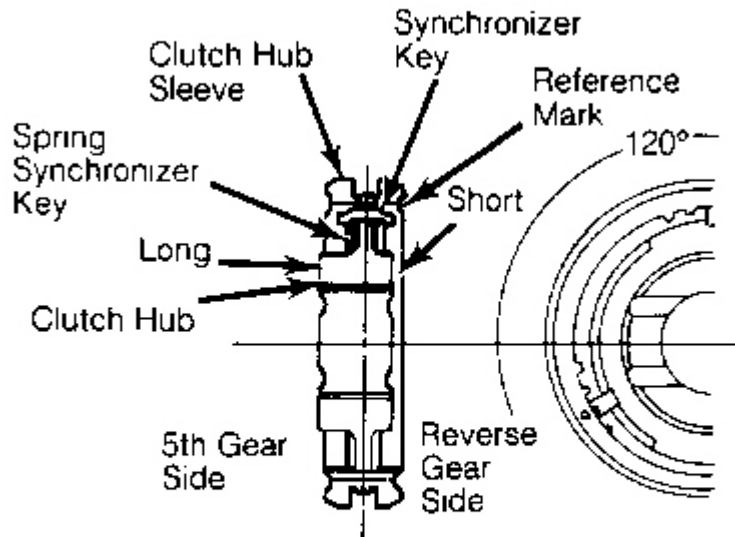

92113894

Fig. 16: Installing Synchronizer Assembly
Courtesy of FORD MOTOR CO.

9. Install and mate 5th-reverse shift fork and shift rail assembly to counter lever end. Install assembly in case, aligning threaded fixing bolt bores, in rail and transmission case. Tighten to specification. See **TORQUE SPECIFICATIONS** table at end of article.
10. Position oil passage to transmission case and install bolt. Install split washer and thrust washer onto countershaft. Install reverse synchronizer ring and needle bearing into reverse gear.
11. Install counter reverse gear and needle bearings onto counter shaft as an assembly. Install thrust washer and press forward by hand against shoulder on countershaft. Maintain forward pressure and measure end play with feeler gauge. Counter reverse gear end play should be .010-.014" (.25-.36 mm). Replace thrust washer to obtain proper end play.
12. Temporarily install a spacer in place of countershaft bearing. Loosely install countershaft lock nut to retain components. Install reverse idler gear assembly.
13. Drive sleeve and reverse gear assembly onto output shaft. Install reverse gear with longer flange facing forward. Install output shaft rear bearing.
14. Remove temporary spacer from countershaft. Install countershaft rear bearing by hand. Ensure bearing is fully seated to avoid damage to output shaft threads.
15. Lock transmission into 1st and 3rd gear. Install NEW output and countershaft lock nuts by hand. Tighten to specification. See **TORQUE SPECIFICATIONS** table. Stake lock nuts to bottom of shaft.
16. Install speedometer drive gear (if equipped). Install transmission extension housing and top cover.

Tighten bolts to specification. See **TORQUE SPECIFICATIONS** table. Fill transmission with Dexron II transmission fluid.