

DISASSEMBLY

ENGINE

Special Tool(s)

SPECIAL TOOL SPECIFICATION



ST2599-A

Alignment Plate, Camshaft
303-465 (T94P-6256-CH)



ST1910-A

Engine Stand
014-00232 or equivalent

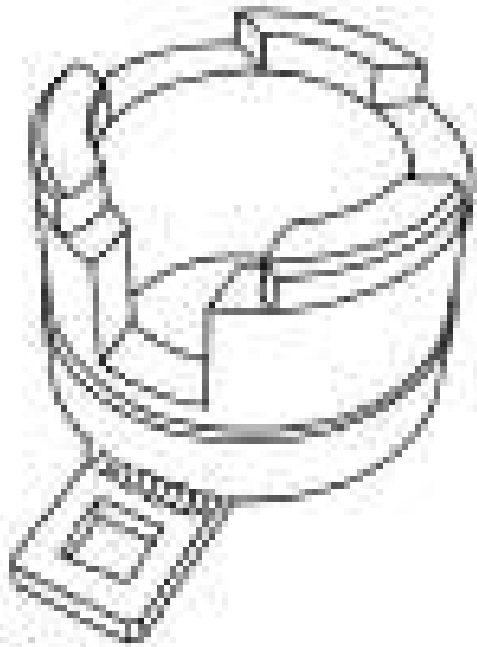

ST3054-A

Holding Tool, Crankshaft Damper
303-1416

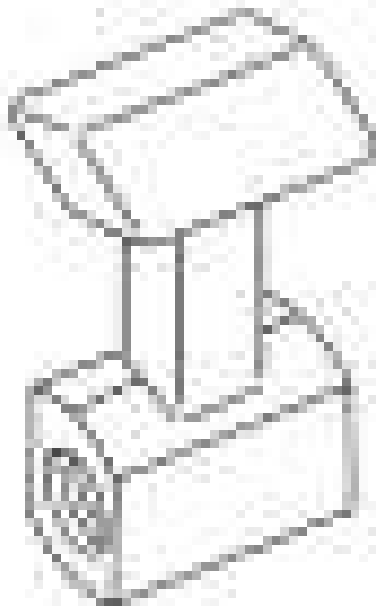

ST2758-A

Holding Tool, Flywheel
303-103 (T74P-8375-A)

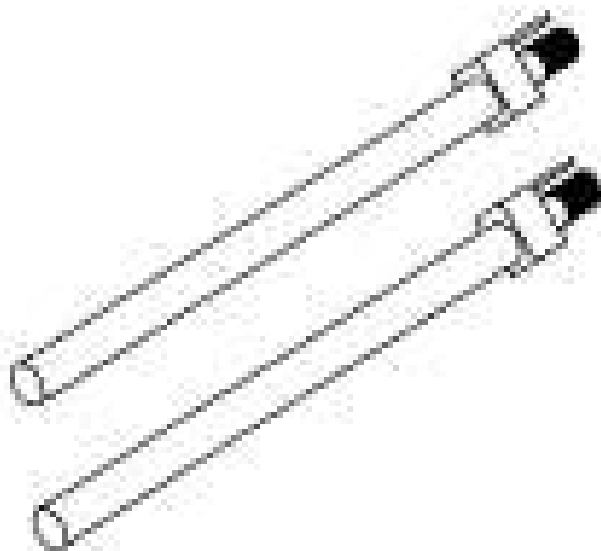

ST1982-A

Installer, Connecting Rod
303-462 (T94P-6136-AH)



ST1385-A

Remover, Oil Seal
303-409 (T92C-6700-CH)

Material

MATERIAL SPECIFICATION

Item	Specification
Motorcraft® Metal Surface Prep ZC-31-A	-
Silicone Brake Caliper Grease and Dielectric Compound XG-3-A	ESE-M1C171-A

NOTE: Do not loosen or remove the crankshaft pulley bolt without first installing the special tools as instructed in this procedure. The crankshaft pulley and the crankshaft timing sprocket are not keyed to the crankshaft. The crankshaft,

the crankshaft sprocket and the pulley are fitted together by friction, using diamond washers between the flange faces on each part. For that reason, the crankshaft sprocket is also unfastened if the pulley bolt is loosened. Before any repair requiring loosening or removal of the crankshaft pulley bolt, the crankshaft and camshafts must be locked in place by the special tools, otherwise severe engine damage may occur.

NOTE: During engine repair procedures, cleanliness is extremely important. Foreign material, including any material created while cleaning gasket surfaces, may enter the cylinders, oil passages, coolant passages or the oil pan, and cause engine failure.

NOTE: Due to the precision fit and timing of the balancer shaft assembly, it cannot be removed from the engine block.

NOTE: For additional information, refer to the exploded views in ASSEMBLY .

Vehicles with manual transmission

NOTE: If the clutch disc and pressure plate are to be reinstalled, bolts must be removed evenly or permanent damage to the diaphragm spring will occur, resulting in complete clutch release.

1.

NOTE: If the parts are to be reused, index-mark the clutch pressure plate to the flywheel.

Remove the 6 bolts, the clutch pressure plate and the clutch disc.

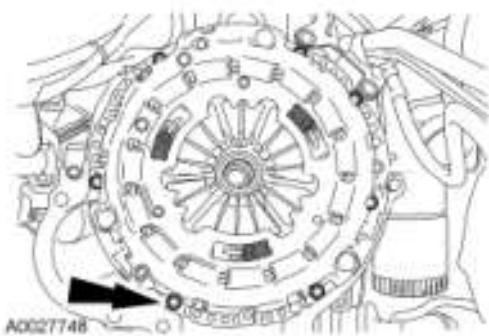

Fig. 155: Locating Clutch Pressure Plate Bolts
Courtesy of FORD MOTOR CO.

All vehicles

2. Using the Flywheel Locking Tool, remove the 6 bolts and the flexplate or flywheel.

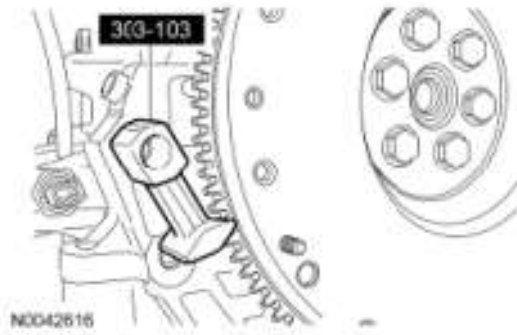

Fig. 156: Removing Flywheel
 Courtesy of FORD MOTOR CO.

3. Mount the engine on a suitable engine stand.
4. Remove the drive belt.

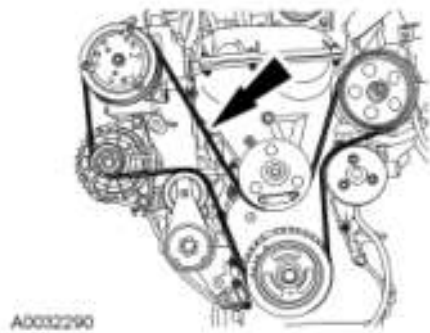

Fig. 157: Locating Drive Belt
 Courtesy of FORD MOTOR CO.

5. Remove the engine oil level indicator, the 2 bolts and the engine oil level indicator tube.



Fig. 158: Locating Engine Oil Level Indicator
 Courtesy of FORD MOTOR CO.

6. Remove the 2 bolts and the front coolant outlet pipe.

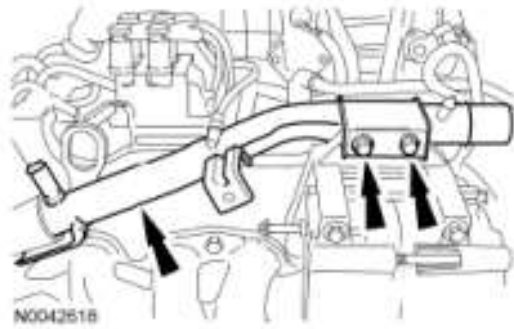

Fig. 159: Locating Front Coolant Outlet Pipe And Bolts
 Courtesy of FORD MOTOR CO.

7. Remove the 4 bolts and the A/C compressor.

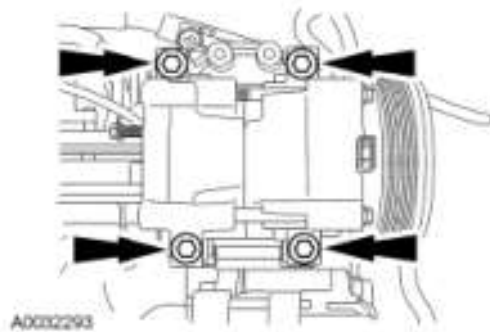

Fig. 160: Locating A/C Compressor Bolts
 Courtesy of FORD MOTOR CO.

8. **NOTE:** The generator will be removed with the accessory bracket.

Remove the 5 bolts and the accessory bracket and generator as an assembly.



Fig. 161: Locating Accessory Bracket Bolts
 Courtesy of FORD MOTOR CO.

9. Remove the 4 bolts and the RH engine mount bracket.

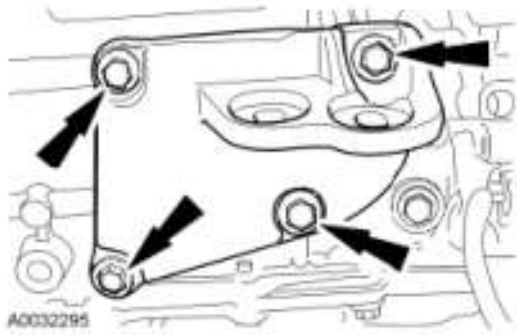

Fig. 162: Locating RH Engine Mount Bracket Bolts
Courtesy of FORD MOTOR CO.

10. Disconnect the coolant hose assembly from the thermostat housing and the PCV fitting on the intake manifold.

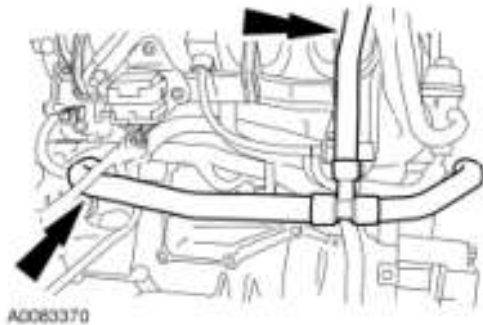

Fig. 163: Locating Coolant Hose
Courtesy of FORD MOTOR CO.

11. Remove the 2 nuts and the coolant tube assembly.

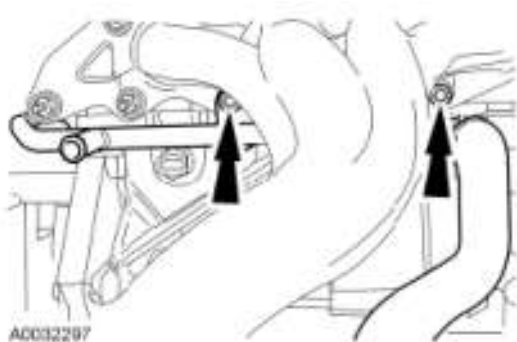

Fig. 164: Locating Coolant Tube Nuts
Courtesy of FORD MOTOR CO.

12. Remove the 7 nuts, the exhaust manifold and gasket.
 - Discard the 7 nuts and the exhaust manifold gasket.

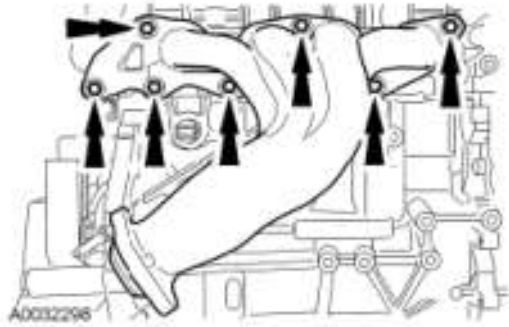

Fig. 165: Locating Exhaust Manifold Nuts
 Courtesy of FORD MOTOR CO.

13. Remove and discard the 7 exhaust manifold-to-cylinder head studs.
14. Clean and inspect the exhaust manifold. For additional information, refer to **ENGINE SYSTEM - GENERAL INFORMATION** .
15. If equipped, remove the block heater.

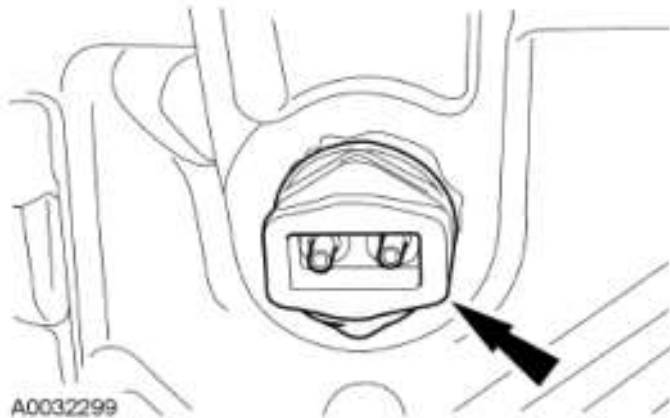

Fig. 166: Locating Block Heater
 Courtesy of FORD MOTOR CO.

16. Remove the rear coolant outlet pipe.
 1. Disconnect the coolant hose.
 2. Remove the 4 bolts, the rear coolant outlet pipe and discard the gasket.

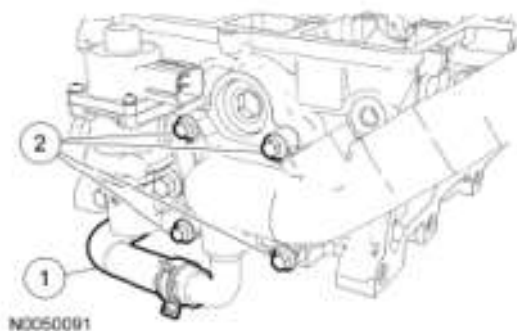

Fig. 167: Locating Rear Coolant Outlet Pipe Bolts
 Courtesy of FORD MOTOR CO.

17. Remove the EGR valve.
 1. Disconnect the electrical connector.
 2. Disconnect the coolant hose.
 3. Remove the 2 bolts, the EGR valve and discard the gasket.

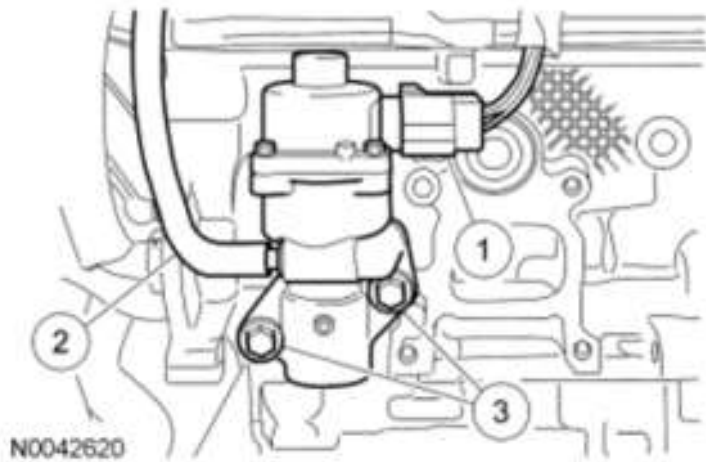

Fig. 168: Identifying Electrical Connector, Coolant Hose And EGR Valve Bolts
Courtesy of FORD MOTOR CO.

18. Remove the 4 bolts and the power steering pump.

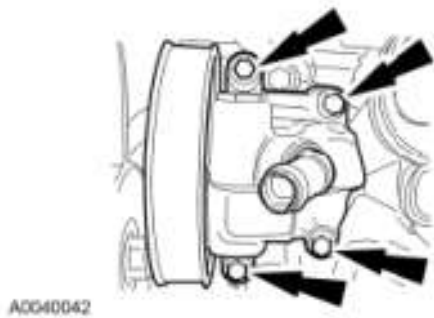

Fig. 169: Locating Power Steering Pump Bolts
Courtesy of FORD MOTOR CO.

19. Disconnect the Idle Air Control (IAC) valve, the Throttle Position (TP) sensor and the Manifold Absolute Pressure (MAP) sensor electrical connectors.

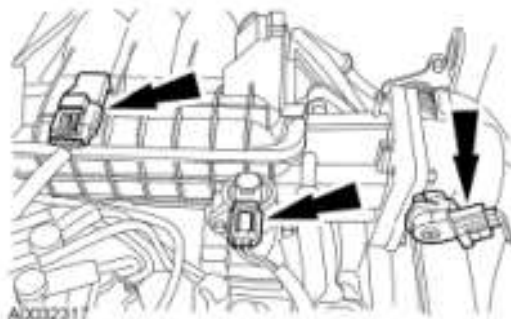

Fig. 170: Locating Manifold Absolute Pressure Sensor Electrical Connectors

Courtesy of FORD MOTOR CO.

20. Disconnect the Crankshaft Position (CKP) sensor and the wiring harness pin-type retainers.

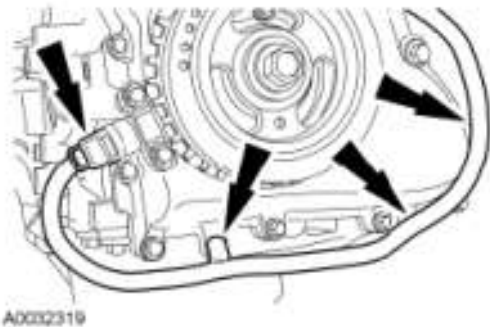

Fig. 171: Locating Crankshaft Position Sensor
Courtesy of FORD MOTOR CO.

21. Disconnect the Knock Sensor (KS) electrical connector, remove the 3 bolts and position the engine wiring harness and bracket aside.

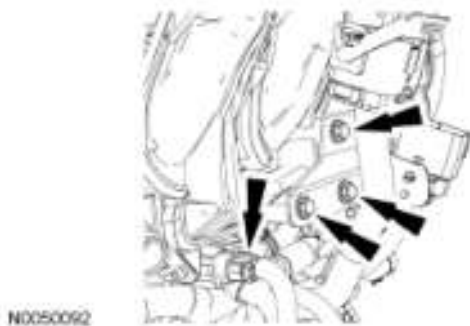

Fig. 172: Locating Knock Sensor Electrical Connector
Courtesy of FORD MOTOR CO.

22. Disconnect the Camshaft Position (CMP) sensor electrical connector and the PCV hose.



Fig. 173: Locating Camshaft Position Sensor Electrical Connector
Courtesy of FORD MOTOR CO.

23. Disconnect the engine wiring harness pin-type retainers from the intake manifold.
24. Remove the 2 bolts and the EGR tube from the intake manifold.

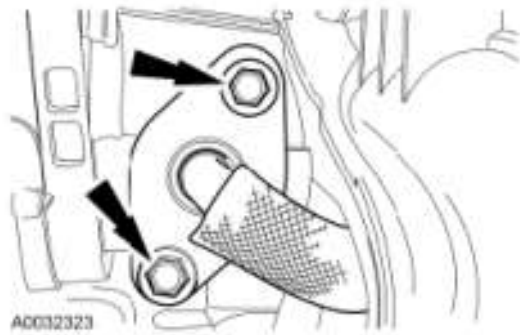

Fig. 174: Locating EGR Tube Bolts
 Courtesy of FORD MOTOR CO.

25. Remove the EGR tube.
- Remove the EGR tube bracket bolt from the intake manifold.
 - Disconnect the EGR tube from the cylinder head.
 - Remove the EGR tube.

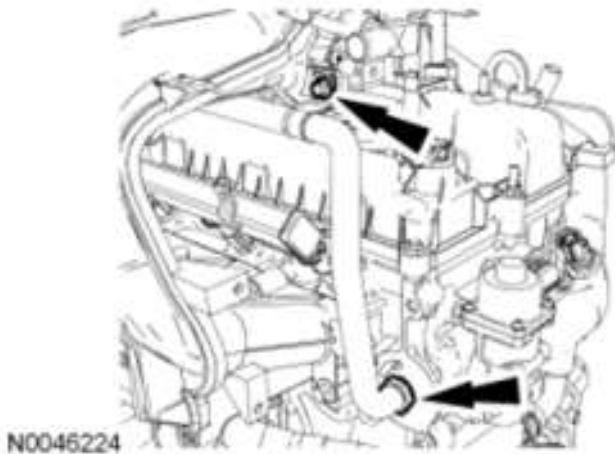

Fig. 175: Locating EGR Tube Bracket Bolt
 Courtesy of FORD MOTOR CO.

NOTE: If the engine is repaired or replaced because of upper engine failure, typically including valve or piston damage, check the intake manifold for metal debris. If metal debris is found, install a new intake manifold. Failure to follow these instructions can result in engine damage.

26.

NOTE: Do not use metal scrapers, wire brushes, power abrasive discs or other abrasive means to clean the sealing surfaces. These tools cause scratches and gouges which make leak paths. Use a plastic scraping tool to remove all traces of old sealant.

Remove the 5 bolts and the intake manifold.

- Clean and inspect the sealing surfaces with metal surface prep and silicone gasket remover. Follow the directions on the packaging.

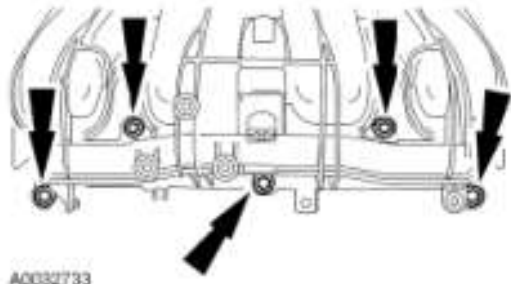

A0032733

Fig. 176: Locating Intake Manifold Bolts
 Courtesy of FORD MOTOR CO.

27. Disconnect the 4 fuel injector electrical connectors and the 2 wiring harness pin-type retainers.

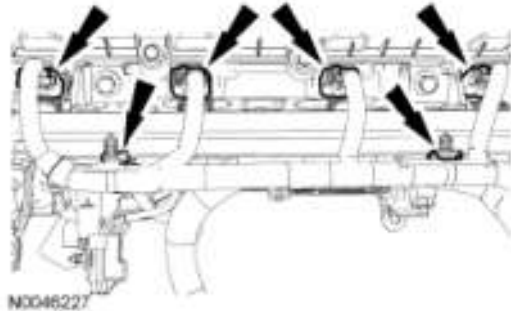

N0046227

Fig. 177: Locating Fuel Injector Electrical Connectors And Wiring Harness Pin-Type Retainers
 Courtesy of FORD MOTOR CO.

28. Disconnect the ignition coil and the Cylinder Head Temperature (CHT) sensor electrical connectors.

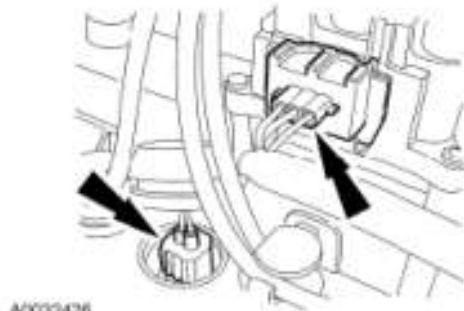

A0032426

Fig. 178: Locating Cylinder Head Temperature Sensor Electrical Connectors
 Courtesy of FORD MOTOR CO.

29. Detach the engine wiring harness anchors from the valve cover studs. Remove the engine wiring harness.

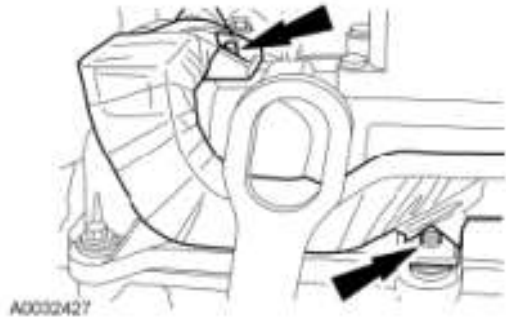

Fig. 179: Locating Engine Wiring Harness Anchors
 Courtesy of FORD MOTOR CO.

30. **NOTE:** Spark plug wires must be connected correctly. Mark the spark plug wires before removing them. Failure to follow this instruction may result in poor engine performance.

NOTE: It is important to twist the spark plug wire boots while pulling upward to avoid possible damage to the spark plug wires.

With a twisting motion, disconnect the spark plug wires from the spark plugs.

31. Remove the 4 bolts and the ignition coil.

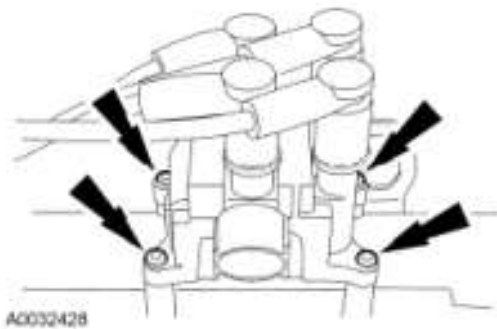

Fig. 180: Locating Ignition Coil Bolts
 Courtesy of FORD MOTOR CO.

32. Remove the 3 bolts and the thermostat housing.

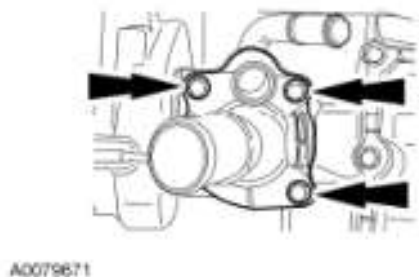
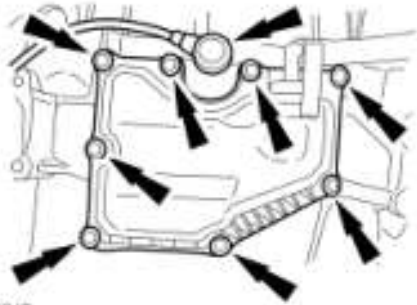

Fig. 181: Locating Thermostat Housing Bolts
 Courtesy of FORD MOTOR CO.

33. Remove the 9 bolts, the KS and the engine vent cover.



N0042847

Fig. 182: Locating Engine Vent Cover Bolts
Courtesy of FORD MOTOR CO.

34. Remove the 4 bolts and the LH engine mount bracket.



A0032331

Fig. 183: Locating LH Engine Mount Bracket Bolts
Courtesy of FORD MOTOR CO.

35. Remove the 2 bolts, fuel rail with the injectors and the ground strap.
- Discard the fuel injector O-ring seals.

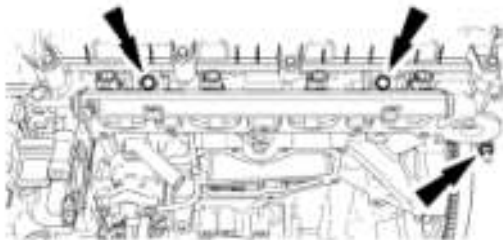

N0046225

Fig. 184: Locating Fuel Rail Bolts
Courtesy of FORD MOTOR CO.

36. Remove the 3 bolts and the coolant pump pulley.

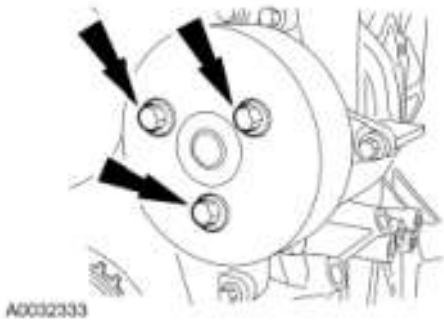

Fig. 185: Locating Coolant Pump Pulley Bolts
 Courtesy of FORD MOTOR CO.

37. Remove the 3 bolts and the coolant pump.
 - Discard the O-ring seal.

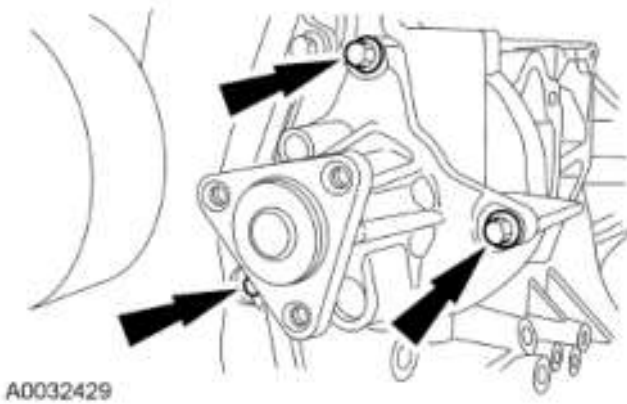

Fig. 186: Locating Coolant Pump Bolts
 Courtesy of FORD MOTOR CO.

38. Remove the CMP sensor, CHT sensor and the spark plugs.

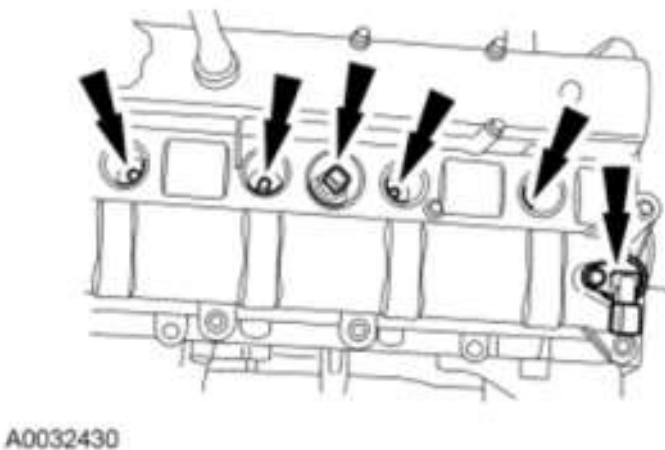
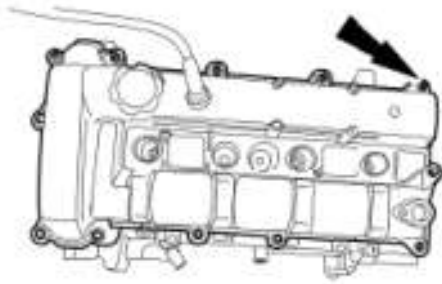

Fig. 187: Locating CMP Sensor
 Courtesy of FORD MOTOR CO.

39. Remove the 14 fasteners and the valve cover.



A0032431

Fig. 188: Locating Valve Cover Fasteners
 Courtesy of FORD MOTOR CO.

40. Remove the 2 bolts and discard the CKP sensor.

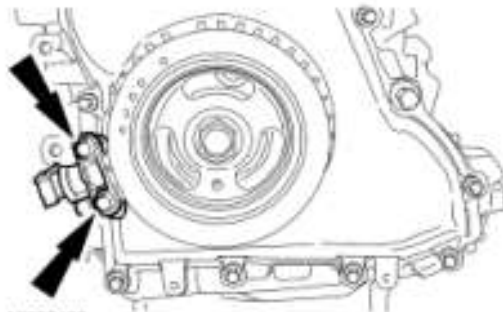

A0032432

Fig. 189: Locating CKP Sensor
 Courtesy of FORD MOTOR CO.

- NOTE:** Do not loosen or remove the crankshaft pulley bolt without first installing the special tools as instructed in this procedure. The crankshaft pulley and the crankshaft timing sprocket are not keyed to the crankshaft. The crankshaft, the crankshaft sprocket and the pulley are fitted together by friction, using diamond washers between the flange faces on each part. For that reason, the crankshaft sprocket is also unfastened if the pulley bolt is loosened. Before any repair requiring loosening or removal of the crankshaft pulley bolt, the crankshaft and camshafts must be locked in place by the special tools, otherwise severe engine damage may occur.
- 41.

NOTE: Failure to position the No. 1 piston at Top Dead Center (TDC) may result in damage to the engine.

NOTE: Turn the crankshaft in the normal direction of rotation only, or the engine may be damaged.

Using the crankshaft pulley bolt, turn the crankshaft clockwise to position the No. 1 piston at Top Dead Center (TDC).

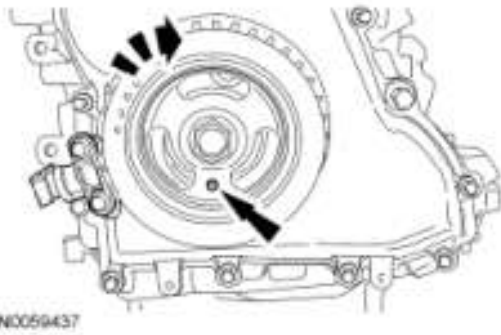

Fig. 190: Identifying Crankshaft Position (Top Dead Center)
 Courtesy of FORD MOTOR CO.

42. **NOTE:** The Camshaft Alignment Plate is for camshaft alignment only. Using this tool to prevent engine rotation may result in engine damage.

NOTE: The camshaft timing slots are offset. If the Camshaft Alignment Plate cannot be installed, rotate the crankshaft one complete revolution clockwise to correctly position the camshafts.

Install the Camshaft Alignment Plate in the slots on the rear of both camshafts.

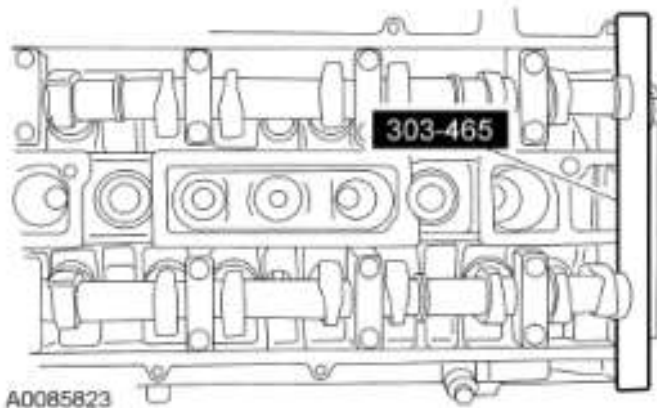

Fig. 191: Identifying Camshaft Alignment Plate
 Courtesy of FORD MOTOR CO.

43. **NOTE:** The crankshaft must remain in the Top Dead Center (TDC) position during removal of the pulley bolt or damage to the engine may occur. Therefore, the crankshaft pulley must be held in place with the Crankshaft Damper Holding Tool and the bolt should be removed using an air impact wrench (1/2-in drive minimum).

NOTE: The crankshaft sprocket diamond washer may come off with the crankshaft pulley. The diamond washer must be replaced; remove and discard the diamond washer. If the diamond washer is not installed, engine damage may occur.

Use the Crankshaft Damper Holding Tool and a suitable 1/2-in drive hand tool to hold the crankshaft

pulley. Use an air impact wrench to remove the crankshaft pulley bolt.

- Remove and discard the crankshaft pulley bolt and washer.
- Remove the crankshaft pulley.
- Remove the diamond washer and discard.

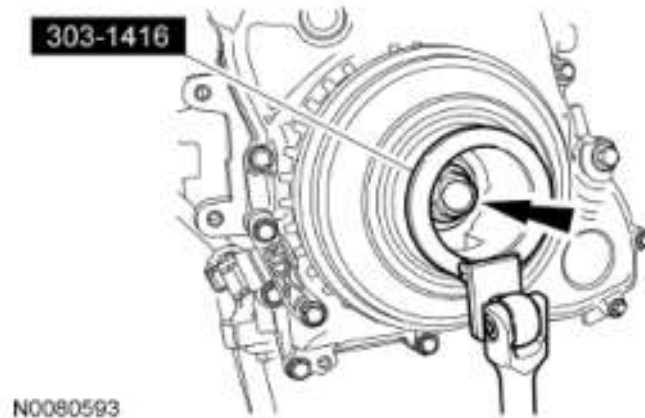

Fig. 192: Locating Crankshaft Pulley With Crankshaft Damper Holding Tool
Courtesy of FORD MOTOR CO.

44. **NOTE:** Use care not to damage the engine front cover or the crankshaft when removing the seal.

Using the Oil Seal Remover, remove the crankshaft front oil seal.

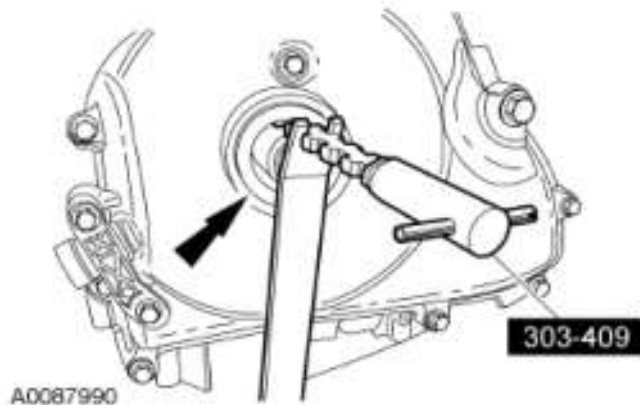

Fig. 193: Removing Crankshaft Front Oil Seal
Courtesy of FORD MOTOR CO.

45. **NOTE:** There is one engine front cover bolt behind the cooling fan drive pulley. To remove this bolt, align one of the cooling fan drive pulley access holes with the bolt head.

Remove the 20 bolts, the stud bolt and the engine front cover.

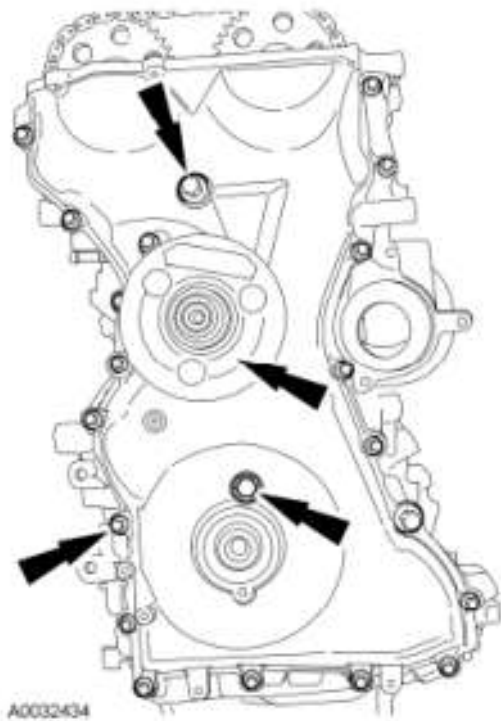

Fig. 194: Locating Engine Front Cover Stud Bolt
 Courtesy of FORD MOTOR CO.

46. Compress the timing chain tensioner in the following sequence.
 1. Using a small pick, release and hold the ratchet mechanism.
 2. While holding the ratchet mechanism in the released position, compress the tensioner by pushing the timing chain arm toward the tensioner.
 3. Insert a paper clip into the hole to retain the tensioner.

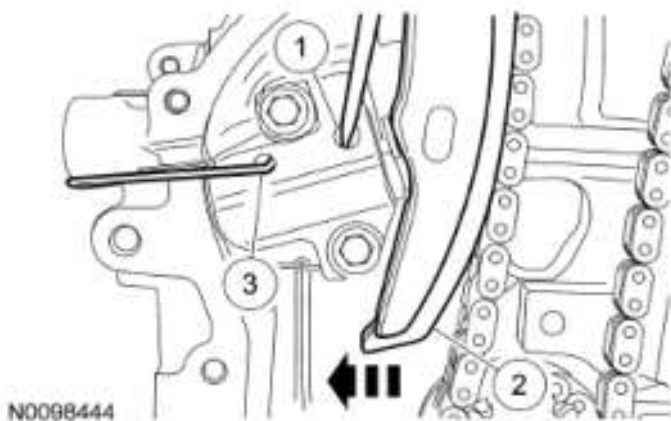

Fig. 195: Inserting Paper Clip Into Hole To Retain Tensioner
 Courtesy of FORD MOTOR CO.

47. Remove the 2 bolts and the timing chain tensioner.

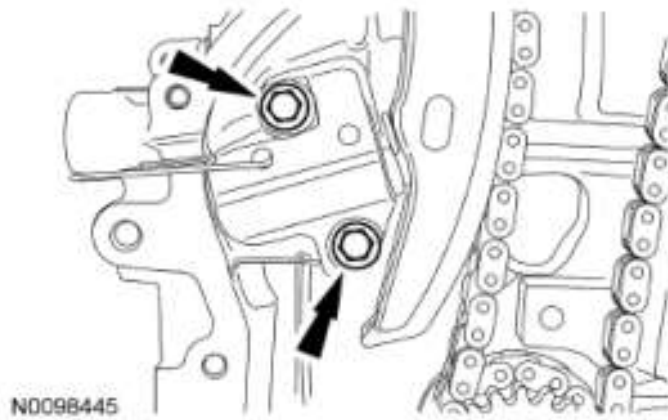

Fig. 196: Locating Timing Chain Tensioner Bolts
Courtesy of FORD MOTOR CO.

48. Remove the RH timing chain guide.

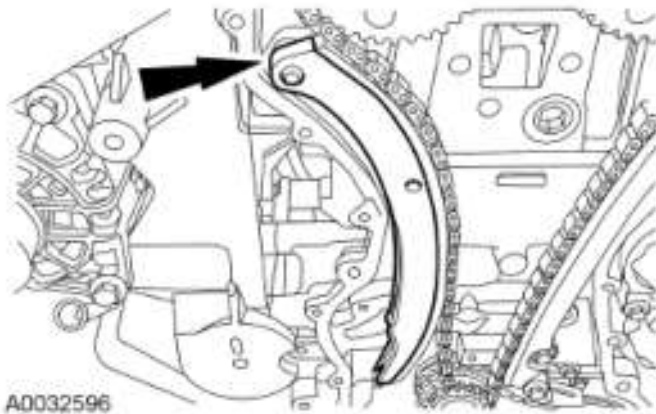

Fig. 197: Locating RH Timing Chain Guide
Courtesy of FORD MOTOR CO.

49. Remove the timing chain.

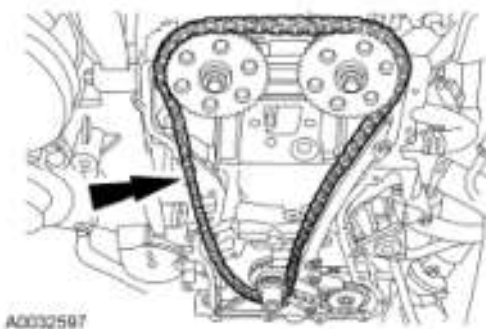

Fig. 198: Locating Timing Chain
Courtesy of FORD MOTOR CO.

50. Remove the 2 bolts and the LH timing chain guide.

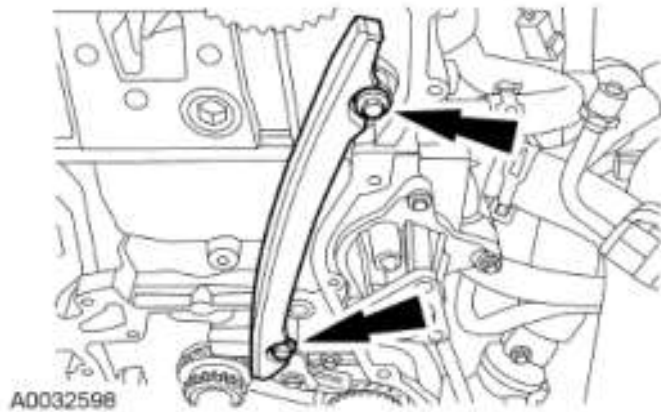

Fig. 199: Locating LH Timing Chain Guide Bolts
 Courtesy of FORD MOTOR CO.

51. **NOTE:** Do not rely on the Camshaft Alignment Plate to prevent camshaft rotation. Damage to the tool or the camshaft may occur.

NOTE: Use a wrench on the flats between cylinders No. 1 and No. 2 to hold the camshaft in place.

Remove the 2 bolts, 2 washers and camshaft drive sprockets.

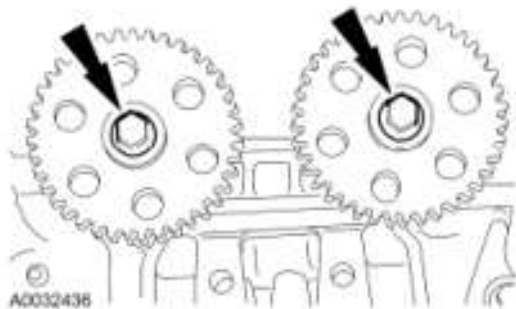

Fig. 200: Locating Camshaft Drive Sprockets Bolts
 Courtesy of FORD MOTOR CO.

52. Remove the oil pump chain drive tensioner.
1. Release the tension on the tensioner spring.
 2. Remove the 2 shoulder bolts and the tensioner.

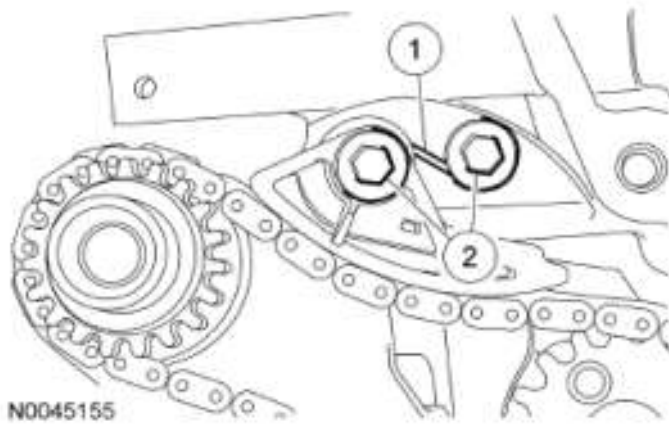

Fig. 201: Identifying Shoulder Bolts And Tensioner
 Courtesy of FORD MOTOR CO.

53. **NOTE:** Remove and discard the crankshaft sprocket diamond washer located behind the crankshaft sprocket.

NOTE: The oil pump chain sprocket must be held in place.

Remove the bolt, the chain, sprockets and diamond washers.

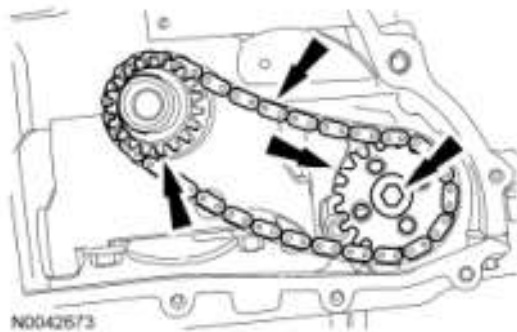

Fig. 202: Locating Oil Pump Chain Sprocket And Chain
 Courtesy of FORD MOTOR CO.

54. Remove the Camshaft Alignment Plate.

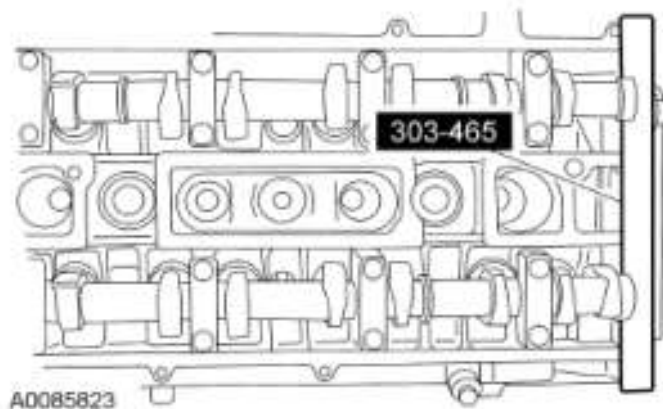

Fig. 203: Identifying Camshaft Alignment Plate
Courtesy of FORD MOTOR CO.

55. **NOTE:** Failure to follow the camshaft loosening procedure may result in damage to the camshafts.
- NOTE:** Mark the location and orientation of each camshaft bearing cap.
- NOTE:** Note the position of the lobes on the No. 1 cylinder before removing the camshafts for assembly reference.

Remove the camshaft bearing caps.

- Loosen the 20 camshaft bearing cap bolts in sequence shown in illustration, one turn at a time.
- Repeat the first step until all tension is released from the camshaft bearing caps.
- Remove the camshaft bearing caps.

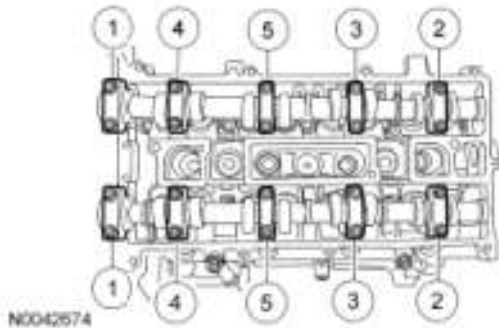

Fig. 204: Identifying Camshaft Bearing Cap Bolts Loosening Sequence
Courtesy of FORD MOTOR CO.

56. Remove the camshafts.
- NOTE:** The cylinder head must be cool before removing it from the engine. Cylinder head warpage may result if a warm or hot cylinder head is removed.
57. **NOTE:** Place clean shop towels over exposed engine cavities. Carefully remove the towels so foreign material is not dropped into the engine. Foreign material, including any material created while cleaning gasket surfaces, may enter the cylinders, oil passages, coolant passages or the oil pan, and cause engine failure.
- NOTE:** Do not use metal scrapers, wire brushes, power abrasive discs or other abrasive means to clean the sealing surfaces. These tools cause scratches and gouges that make leak paths. Use a plastic scraping tool to remove all traces of the head gasket.
- NOTE:** Aluminum surfaces are soft and can be scratched easily. Never place

the cylinder head gasket surface, unprotected, on a bench surface, or the cylinder head may be damaged.

NOTE: The cylinder head bolts must be discarded and new bolts must be installed. They are torque-to-yield designed and cannot be reused.

Remove the 10 bolts and the cylinder head.

- Discard the cylinder head bolts.

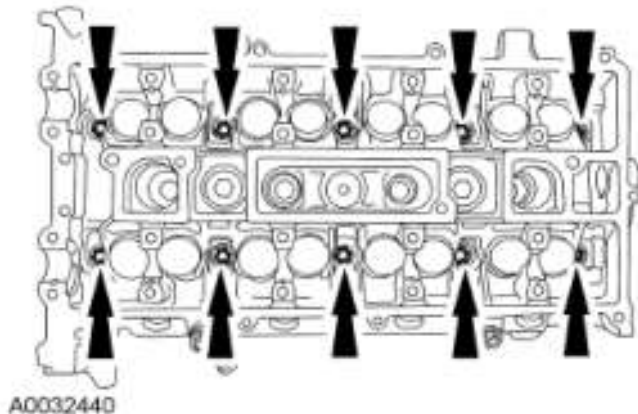

Fig. 205: Locating Cylinder Head Bolts
Courtesy of FORD MOTOR CO.

58. Remove and discard the cylinder head gasket.
59. Remove the cylinder head alignment dowels.

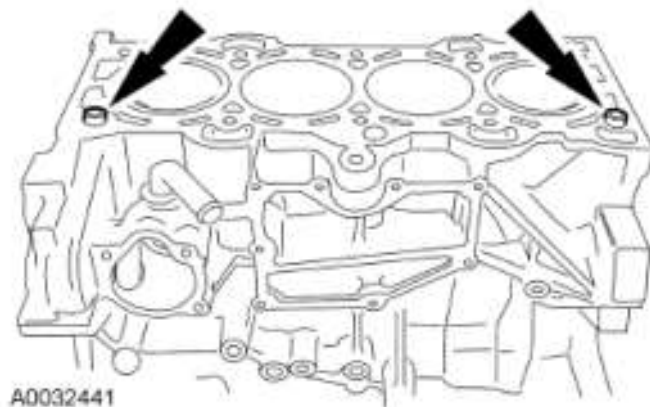

Fig. 206: Locating Cylinder Head Alignment Dowels
Courtesy of FORD MOTOR CO.

60. Remove the 13 bolts and the oil pan.

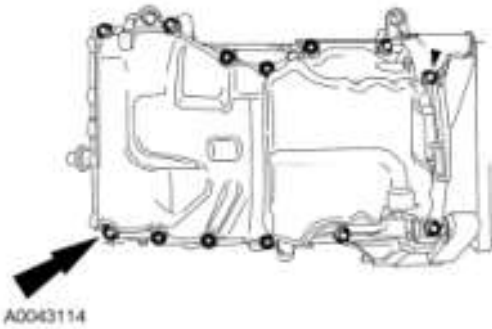

Fig. 207: Locating Oil Pan Bolts
 Courtesy of FORD MOTOR CO.

61. Remove the 6 bolts and the rear crankshaft seal and retainer plate.
 - Discard the crankshaft rear seal and retainer plate assembly.

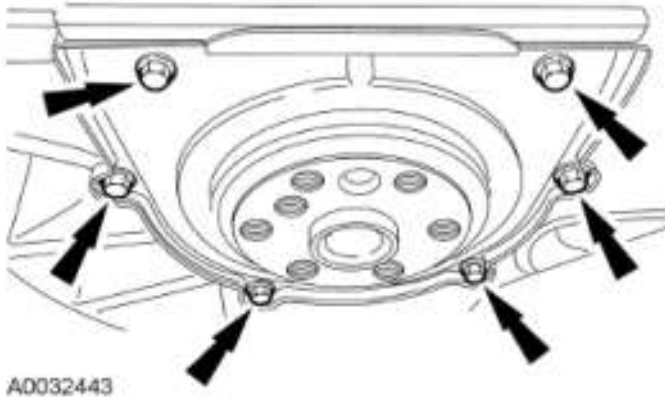

Fig. 208: Locating Rear Crankshaft Seal And Bolts
 Courtesy of FORD MOTOR CO.

62. Remove the 4 bolts, the oil pump pickup tube and discard the gasket.

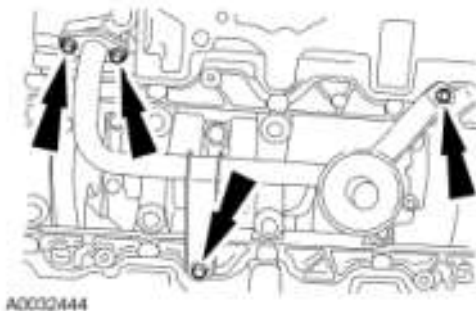

Fig. 209: Locating Oil Pump Pickup Tube Bolts
 Courtesy of FORD MOTOR CO.

63. Remove the 4 bolts and the oil pump assembly.
 - Discard the gasket.

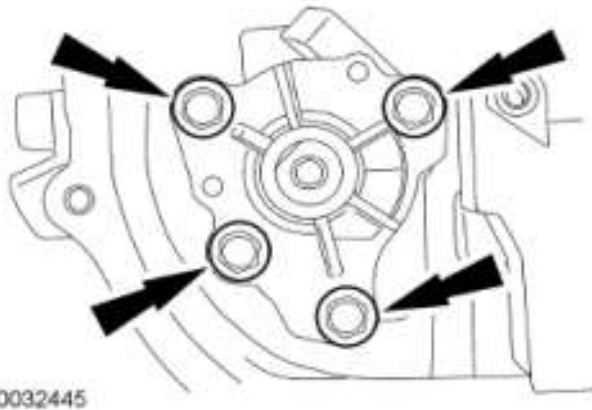

Fig. 210: Locating Oil Pump Assembly Bolts
 Courtesy of FORD MOTOR CO.

64. Before removing the pistons, inspect the top of the cylinder bores. If necessary, remove the ridge or carbon deposits from each cylinder using an abrasive pad or equivalent, following manufacturer's instructions.

NOTE: Clearly mark the connecting rods, connecting rod caps and connecting rod bearings in numerical order for correct orientation for reassembly.

65.

Remove the connecting rod cap bolts and cap.

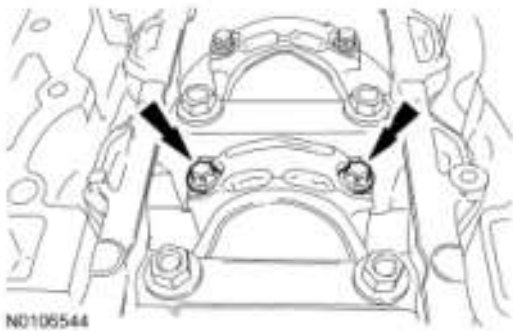

Fig. 211: Locating Connecting Rod Cap Bolts
 Courtesy of FORD MOTOR CO.

66. **NOTE:** Do not scratch the cylinder walls or crankshaft journals with the connecting rod.

Using the Connecting Rod Installer, remove the piston/rod assembly from the engine block.

- Repeat the previous 2 steps until all the piston/rod assemblies are removed from the engine block.

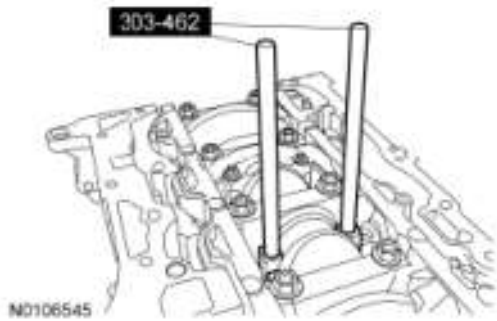

Fig. 212: Removing Piston/Rod Assembly From Engine Block
 Courtesy of FORD MOTOR CO.

67. Remove the bolts in the sequence shown in illustration.
- Remove the main bearing beam.
 - Discard the bolts.

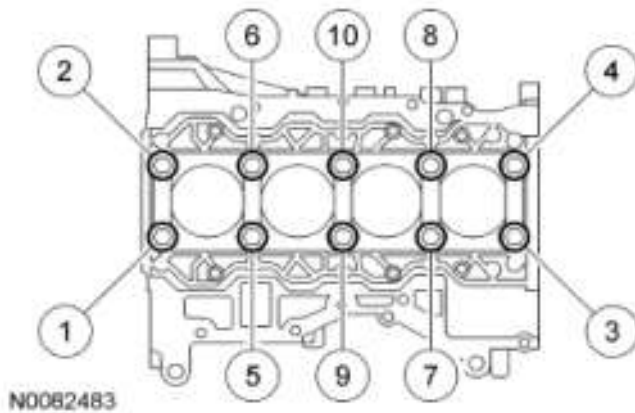

Fig. 213: Identifying Main Bearing Bolts
 Courtesy of FORD MOTOR CO.

68. Remove the crankshaft from the engine block.

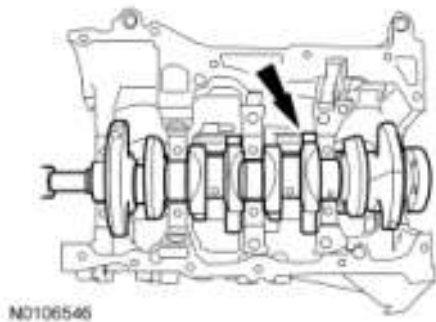
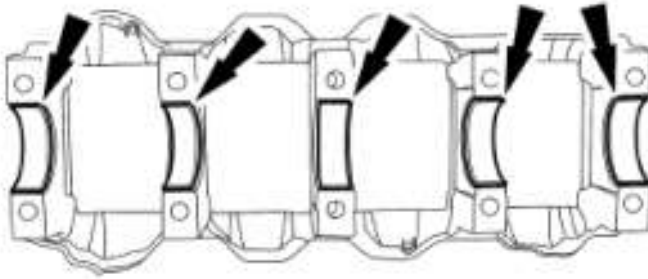

Fig. 214: Locating Crankshaft
 Courtesy of FORD MOTOR CO.

NOTE: If the main bearings are being reused, mark them in order for correct orientation and reassembly.

Remove the main bearings from the main bearing beam.



N0082485

Fig. 215: Locating Main Bearings
Courtesy of FORD MOTOR CO.

70. **NOTE:** If the main bearings are being reused, mark them in order for correct orientation and reassembly.

NOTE: The center bulkhead has the thrust bearing.

Remove the main bearings from the cylinder block.

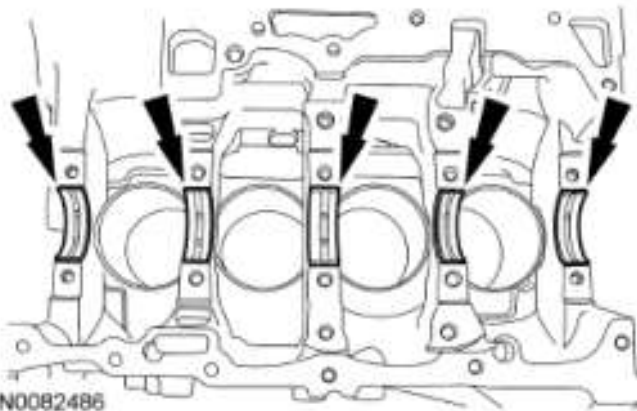

N0082486

Fig. 216: Locating Main Bearings On Cylinder Block
Courtesy of FORD MOTOR CO.

71. **NOTE:** If the oil squirters are being reused, mark them in order for correct location during reassembly.

NOTE: The front bulkhead does not have an oil squirter.

Remove the 4 oil squirters.

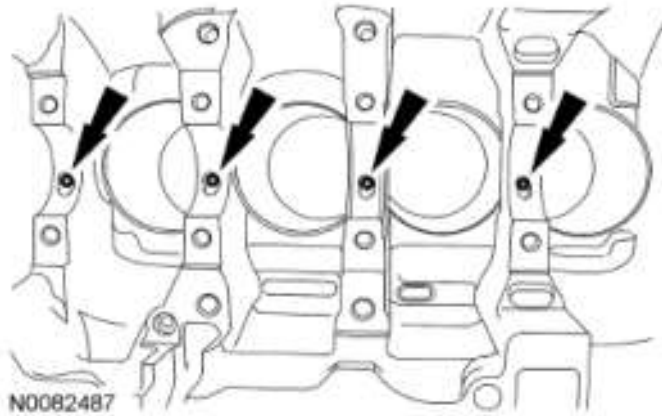

Fig. 217: Locating Oil Squirters
Courtesy of FORD MOTOR CO.

72. Inspect the cylinder block, main bearing beam, pistons and connecting rods. For additional information, refer to **ENGINE SYSTEM - GENERAL INFORMATION** .