

# DISASSEMBLY

## ENGINE

### Special Tool(s)

#### SPECIAL TOOL DESCRIPTION CHART

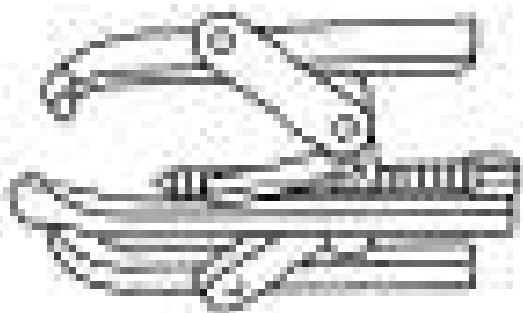

3 Jaw Puller 303-D121

**ST1184-A**

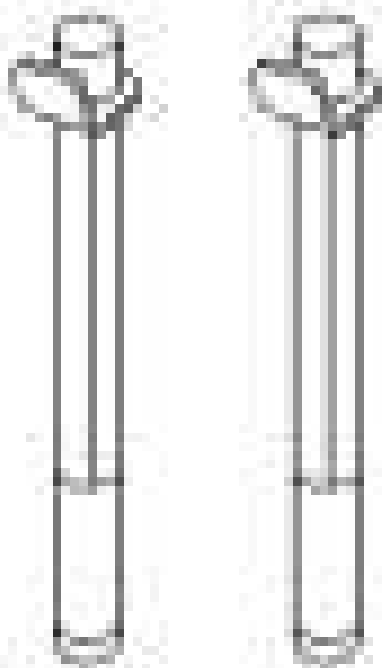

Installer, Connecting Rod 303-442 (T93P-6136-A)

**ST1337-A**



Lifting Bracket, Engine 303-F047 (014-00073) or equivalent

**ST1377-A**

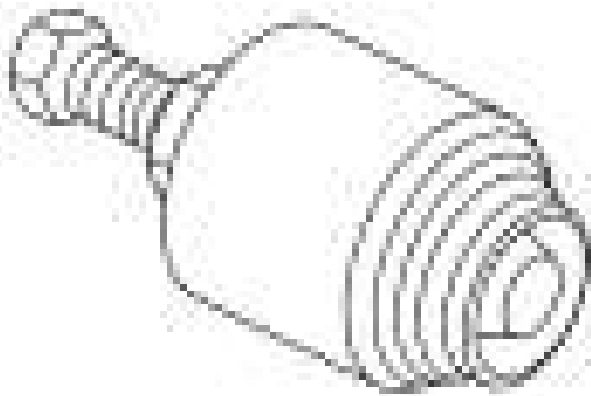

Remover, Crankshaft Front Oil Seal 303-107 (T74P-6700-A)

**ST1730-A**

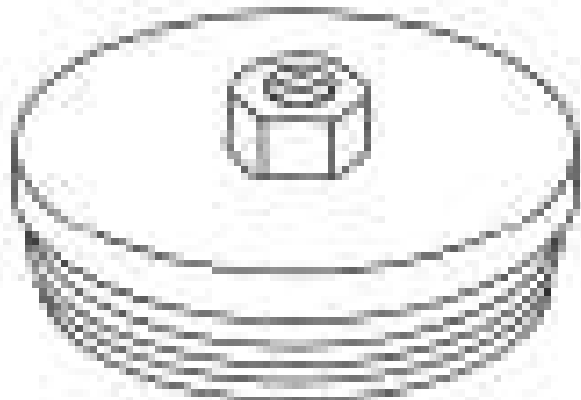

Remover, Crankshaft Rear Oil Seal 303-519 (T95P-6701-DH)

**ST1382-A**



Slide Hammer 100-001 (T50T-100-A)

ST1185-A

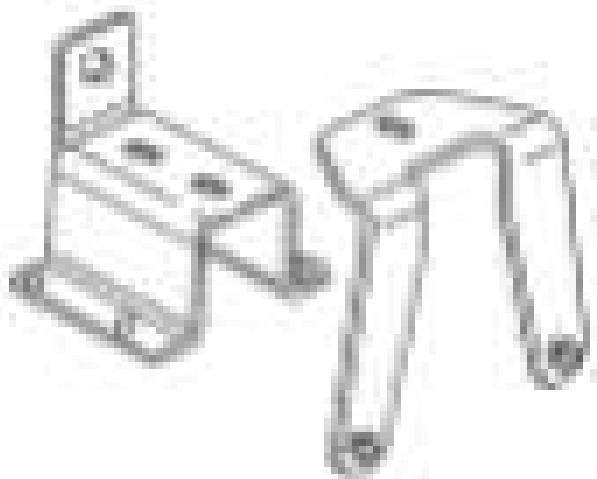

Support Brackets, Engine 303-1507 or equivalent

ST3110-A

**Material**

**MATERIAL SPECIFICATIONS**

| Item                                      | Specification |
|---|---------------|
| Motorcraft® Metal Surface Prep ZC-31-A    | -             |
| Motorcraft® Silicone Gasket Remover ZC-30 | -             |

**NOTE:** Remove the cylinder heads before removing the crankshaft. Failure to do so may result in engine damage.

**NOTE:** During engine repair procedures, cleanliness is extremely important. Any foreign material, including any material created while cleaning gasket surfaces that enters the oil passages, coolant passages or the oil pan, may cause engine failure.

**NOTE:** The flexplate and crankshaft rear seal must be removed before mounting the engine on the engine stand.

**NOTE:** For additional information, refer to the exploded view under the ASSEMBLY procedure .

1. Remove the 8 bolts and the flexplate.
  - Discard the 8 flexplate bolts.

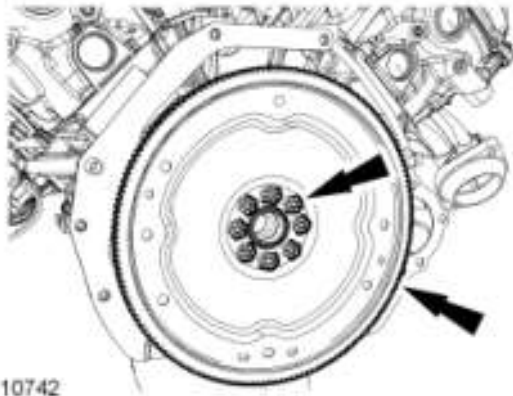

**Fig. 285: Locating Bolts And Flexplate**  
Courtesy of FORD MOTOR CO.

2. Remove the spacer plate.

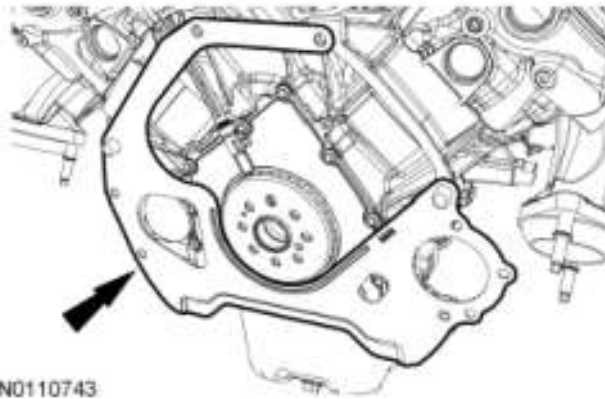

**Fig. 286: Locating Spacer Plate**  
Courtesy of FORD MOTOR CO.

3. **NOTE:** Inspect the ignition pulse ring for damage. If the ignition pulse ring has been dropped or has any visual damage, it must be discarded.

Remove the crankshaft ignition pulse ring.

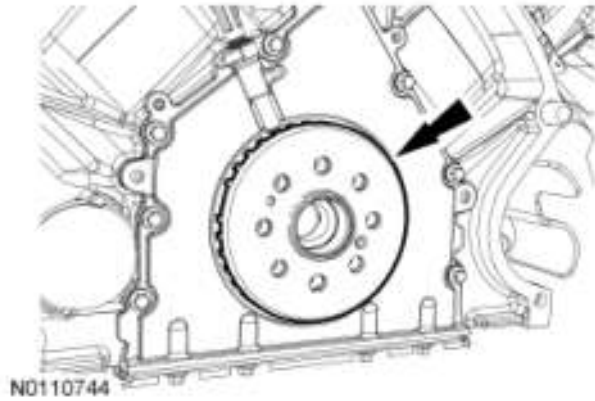

**Fig. 287: Locating Crankshaft Ignition Pulse Ring**  
 Courtesy of FORD MOTOR CO.

4. Disconnect the electrical connector and remove the bolt and the Crankshaft Position (CKP) sensor.

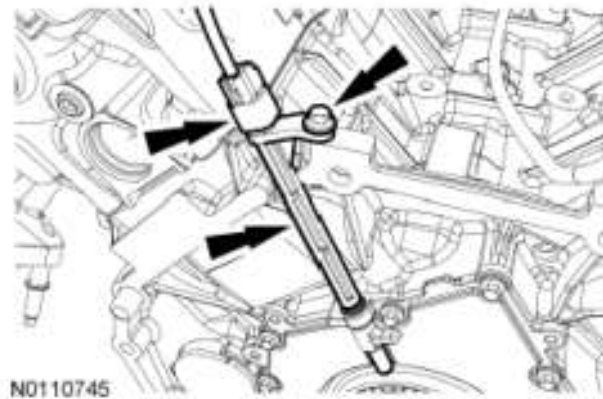

**Fig. 288: Locating Electrical Connector, Bolt And Crankshaft Position Sensor**  
 Courtesy of FORD MOTOR CO.

5. Using the Slide Hammer and the Crankshaft Rear Oil Seal Remover, remove and discard the crankshaft rear seal.

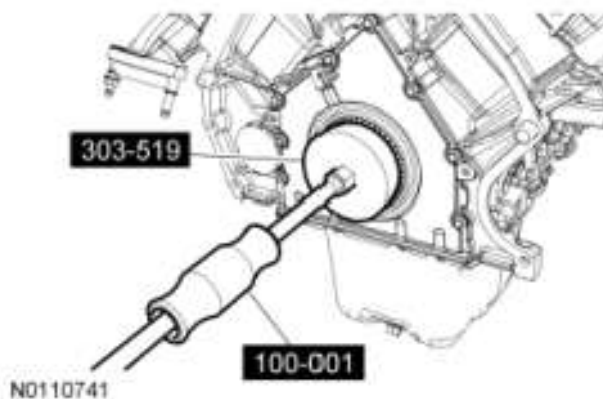

**Fig. 289: Removing Crankshaft Rear Seal Using Slide Hammer And Crankshaft Rear Oil Seal Remover**  
 Courtesy of FORD MOTOR CO.

6. Mount the engine on a work stand.
7. Remove the Engine Lifting Bracket and Engine Support Brackets.

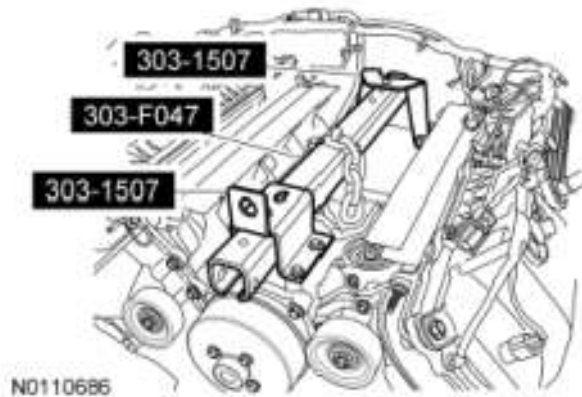

**Fig. 290: Identifying Engine Lifting Bracket And Engine Support Brackets**  
Courtesy of FORD MOTOR CO.

8. Disconnect the Engine Oil Pressure (EOP) switch electrical connector and wiring harness retainers.

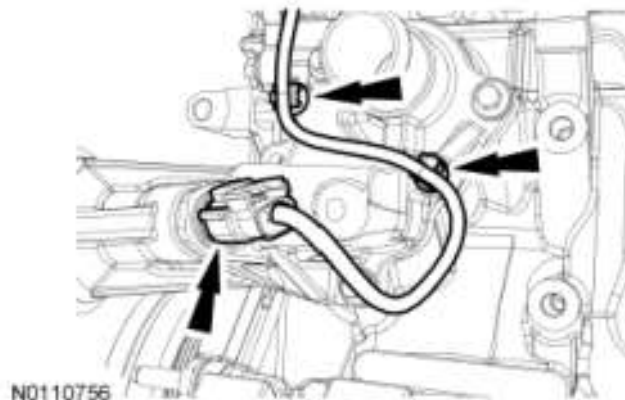

**Fig. 291: Locating Engine Oil Pressure Switch Electrical Connector And Wiring Harness Retainers**  
Courtesy of FORD MOTOR CO.

9. Disconnect the LH Variable Camshaft Timing (VCT) system oil control solenoid electrical connector and the 2 wiring harness retainers.

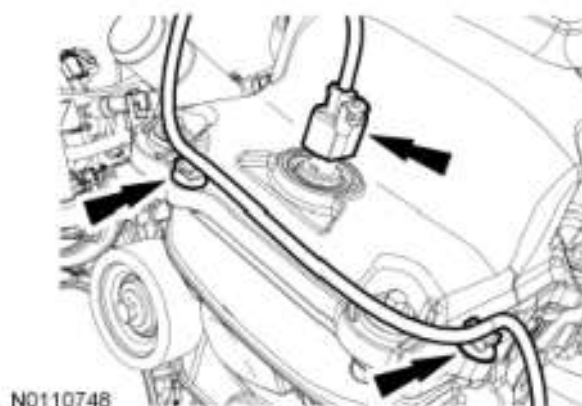

**Fig. 292: Locating LH Variable Camshaft Timing System Oil Control Solenoid Electrical Connector And Wiring Harness Retainers**  
Courtesy of FORD MOTOR CO.

10. Disconnect the 3 engine wiring harness position retainers from the LH valve cover.

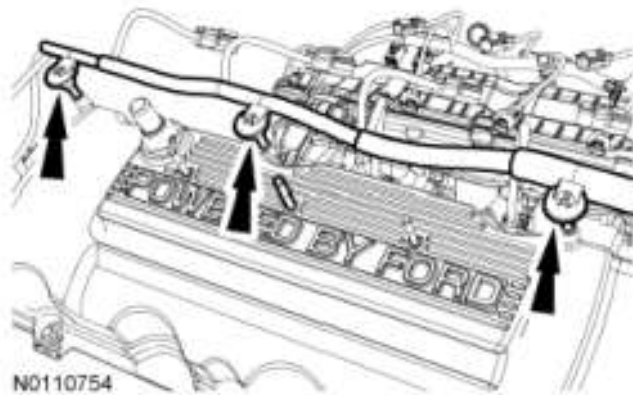

**Fig. 293: Locating Engine Wiring Harness Position Retainers On LH Valve Cover**  
Courtesy of FORD MOTOR CO.

11. Disconnect the wiring harness retainer, the Knock Sensor (KS) and Cylinder Head Temperature (CHT) sensor electrical connectors.

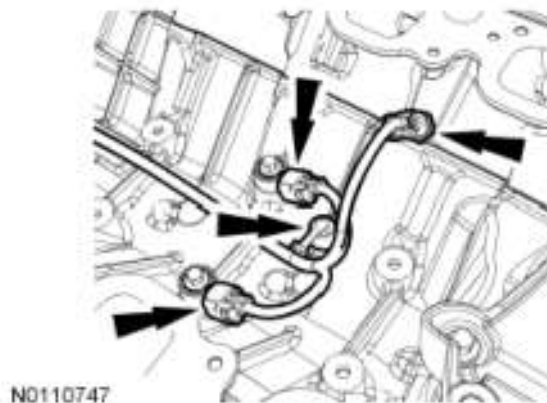

**Fig. 294: Locating Wiring Harness Retainer, Knock Sensor And Cylinder Head Temperature Sensor Electrical Connectors**  
Courtesy of FORD MOTOR CO.

12. Disconnect the LH and RH Camshaft Position (CMP) electrical connectors.

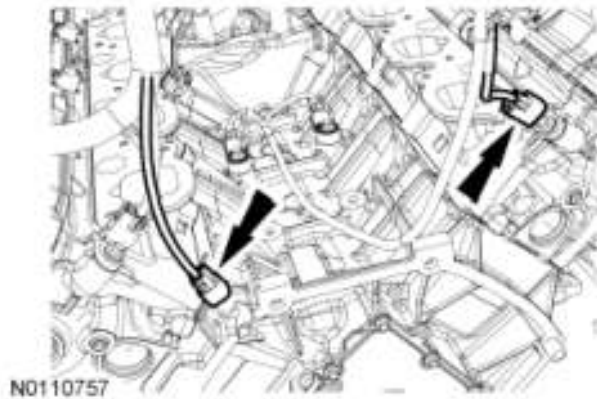

**Fig. 295: Locating LH And RH Camshaft Position Electrical Connectors**  
Courtesy of FORD MOTOR CO.

13. Remove the nut and the wiring harness ground cable.

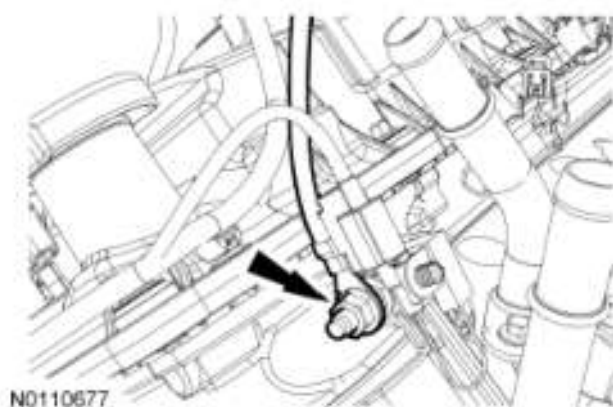

**Fig. 296: Locating Wiring Harness Ground Cable Nut**  
Courtesy of FORD MOTOR CO.

14. Remove the nut and the radio interference capacitor.

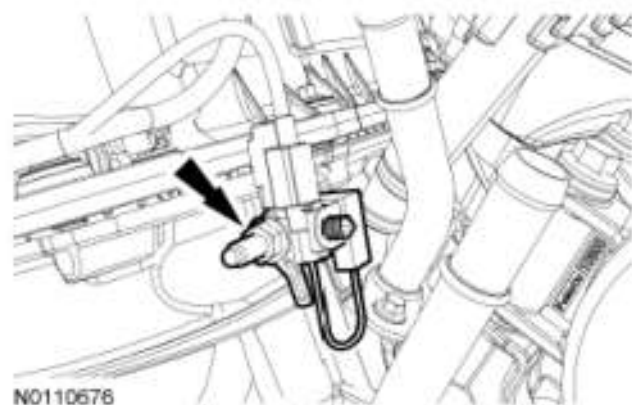

**Fig. 297: Locating Radio Interference Capacitor Nut**  
Courtesy of FORD MOTOR CO.

15. Disconnect the RH VCT system oil control solenoid electrical connector and the 2 wiring harness retainers.



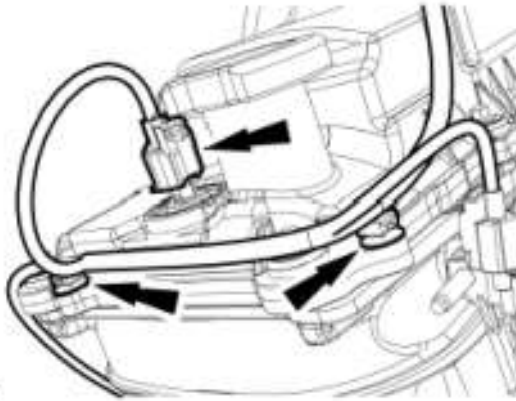

N0110750

**Fig. 298: Locating RH VCT System Oil Control Solenoid Electrical Connector And Wiring Harness Retainers**  
 Courtesy of FORD MOTOR CO.

16. Disconnect the 3 engine wiring harness position retainers from the RH valve cover and remove the engine wiring harness.

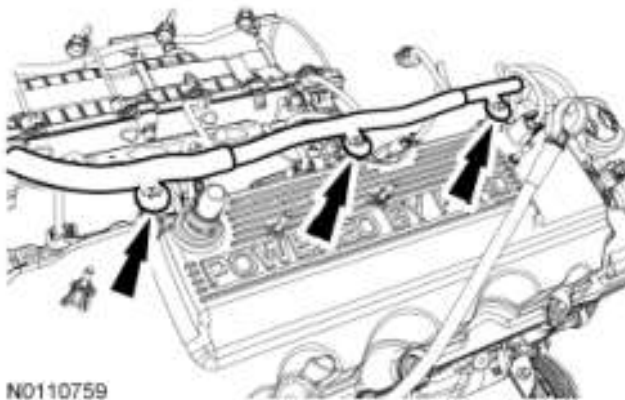

N0110759

**Fig. 299: Locating Engine Wiring Harness Position Retainers On RH Valve Cover**  
 Courtesy of FORD MOTOR CO.

17. **NOTE:** RH shown in illustration, LH similar.

Disconnect the 8 ignition wires from the valve cover retainers and the lower spark plugs.

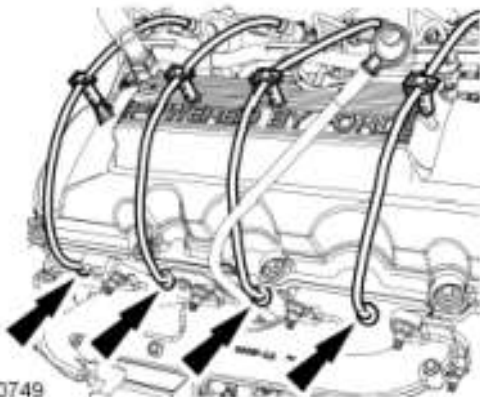

N0110749

**Fig. 300: Locating Ignition Wires Of Valve Cover Retainers And Lower Spark Plugs**  
Courtesy of FORD MOTOR CO.

18. Remove the 2 bolts and the LH and RH CMP sensors.

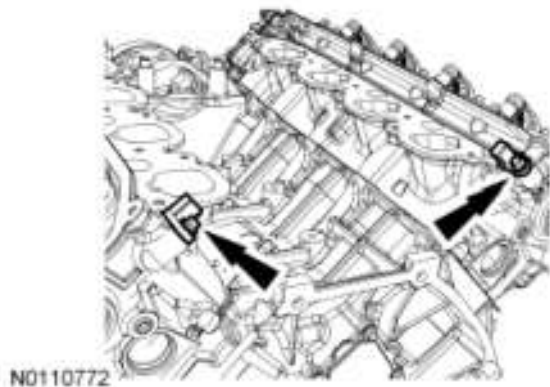

**Fig. 301: Locating Bolts And CMP Sensors**  
Courtesy of FORD MOTOR CO.

19. Remove the 2 bolts and the RH and LH KS .

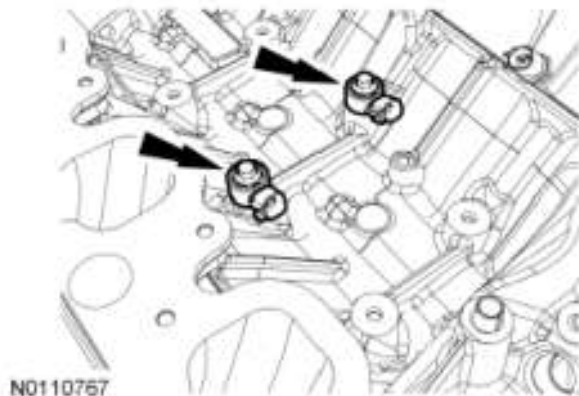

**Fig. 302: Locating Bolts And Knock Sensor**  
Courtesy of FORD MOTOR CO.

20. Remove the 2 bolts and the LH exhaust manifold heat shield.

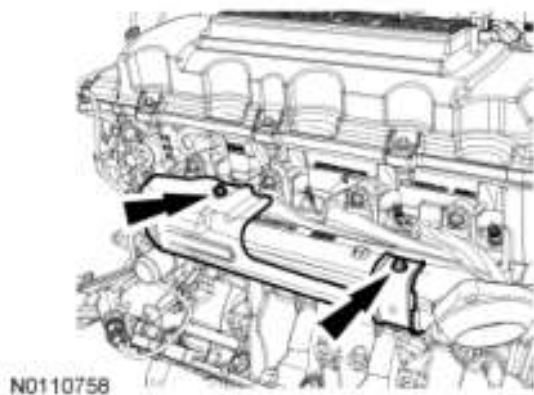

**Fig. 303: Locating Exhaust Manifold Heat Shield With Mounting Bolts**

**Courtesy of FORD MOTOR CO.**

21. Remove the 8 nuts, the 8 studs, the LH exhaust manifold and the 2 gaskets.
  - Discard the gaskets, nuts and studs.
  - Inspect the exhaust manifold. For additional information, refer to **ENGINE SYSTEM - GENERAL INFORMATION -- F150** .

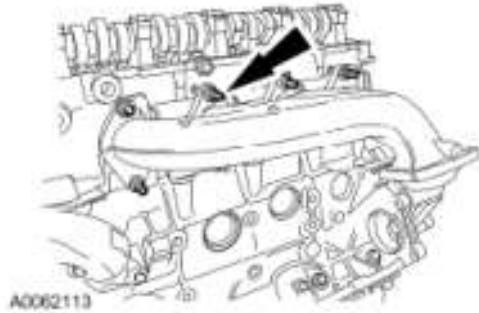

**Fig. 304: Locating Exhaust Manifold Nuts And Studs**  
**Courtesy of FORD MOTOR CO.**

22. Remove the 2 bolts and the RH exhaust manifold heat shield.

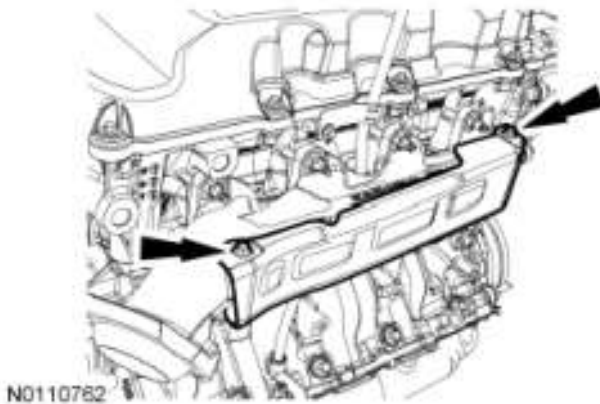

**Fig. 305: Locating RH Exhaust Manifold Heat Shield Bolts**  
**Courtesy of FORD MOTOR CO.**

23. Remove the 8 nuts, the 8 bolts, the RH exhaust manifold and the 2 gaskets.
  - Discard the gaskets, nuts and studs.
  - Inspect the exhaust manifold. For additional information, refer to **ENGINE SYSTEM - GENERAL INFORMATION -- F150** .

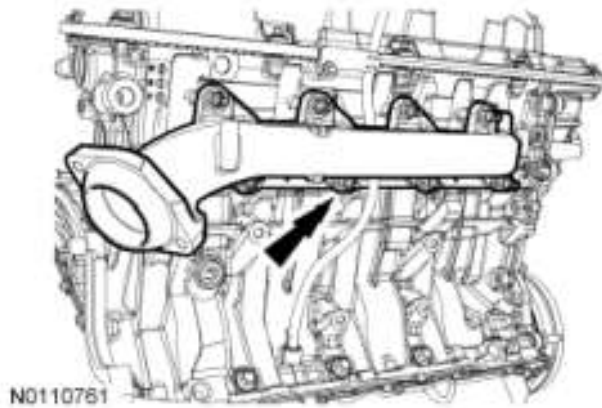

**Fig. 306: Locating RH Exhaust Manifold Nuts And Studs**  
 Courtesy of FORD MOTOR CO.

24. Remove the 3 bolts and the LH engine support insulator-to-cylinder block bracket.

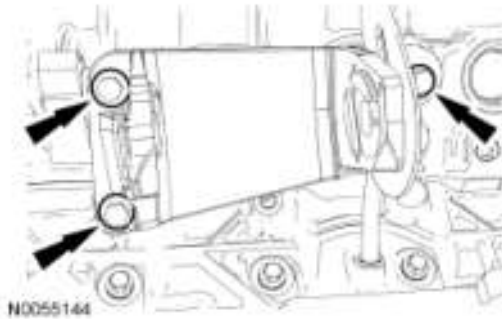

**Fig. 307: Locating Bolts And LH Engine Support Insulator-To-Cylinder Block Bracket**  
 Courtesy of FORD MOTOR CO.

25. Remove the 3 bolts and the RH engine support insulator.



**Fig. 308: Locating RH Engine Support Insulator Bolts**  
 Courtesy of FORD MOTOR CO.

26. Remove the bolt and the oil level indicator tube.
  - Discard the O-ring seal.

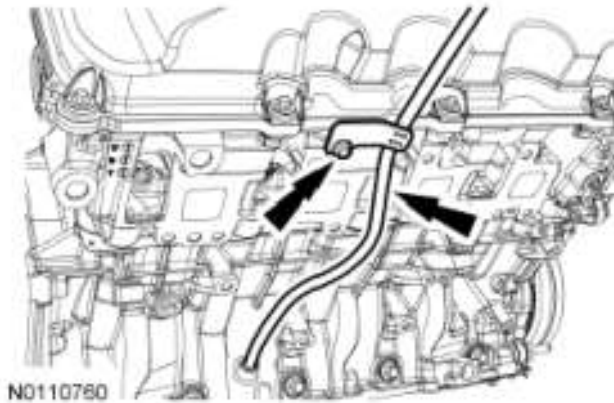

**Fig. 309: Locating Bolt And Oil Level Indicator Tube**  
 Courtesy of FORD MOTOR CO.

27.

**NOTE:** Do not use metal scrapers, wire brushes, power abrasive discs or other abrasive means to clean the sealing surfaces. These tools cause scratches and gouges which make leak paths. Use a plastic scraping tool to remove all traces of old sealant.

**NOTE:** Remove the valve cover carefully, or the Variable Camshaft Timing (VCT) system oil control solenoid may be damaged.

**NOTE:** The bolts are part of the valve cover and should not be removed.

Loosen the 10 bolts and remove the LH valve cover.

- Clean the valve cover mating surface of the cylinder head with silicone gasket remover and metal surface prep. Follow the directions on the packaging.
- Inspect the valve cover gasket. If the gasket is damaged, remove and discard the gasket. Clean the valve cover gasket groove with soap and water or a suitable solvent.

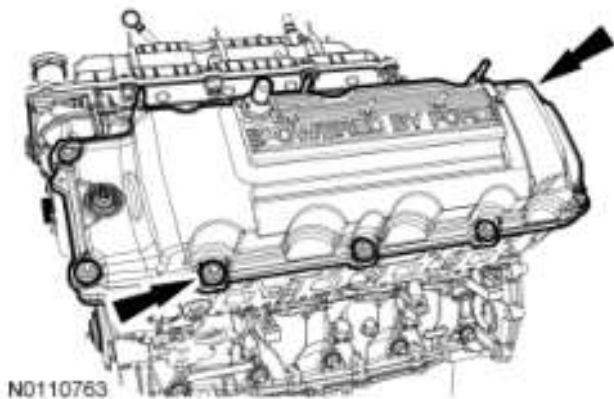

**Fig. 310: Locating Bolts And LH Valve Cover**  
 Courtesy of FORD MOTOR CO.

28.

**NOTE:** Do not use metal scrapers, wire brushes, power abrasive discs or other abrasive means to clean the sealing surfaces. These tools cause

28. scratches and gouges which make leak paths. Use a plastic scraping tool to remove all traces of old sealant.

**NOTE:** Remove the valve cover carefully, or the Variable Camshaft Timing (VCT) system oil control solenoid may be damaged.

**NOTE:** The bolts are part of the valve cover and should not be removed.

Loosen the 10 bolts and remove the RH valve cover.

- Clean the valve cover mating surface of the cylinder head with silicone gasket remover and metal surface prep. Follow the directions on the packaging.
- Inspect the valve cover gasket. If the gasket is damaged, remove and discard the gasket. Clean the valve cover gasket groove with soap and water or a suitable solvent.

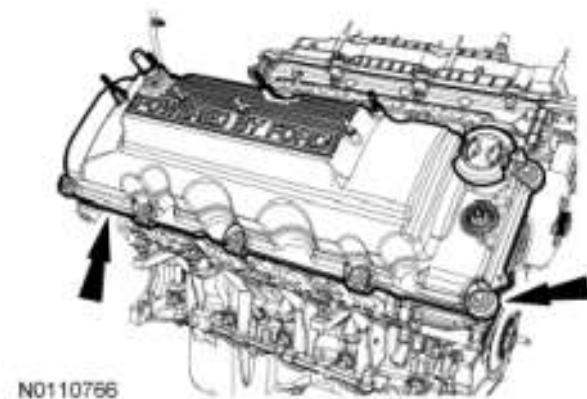

**Fig. 311: Locating Bolts And RH Valve Cover**  
Courtesy of FORD MOTOR CO.

29. Remove the 4 bolts and the oil filter adapter.

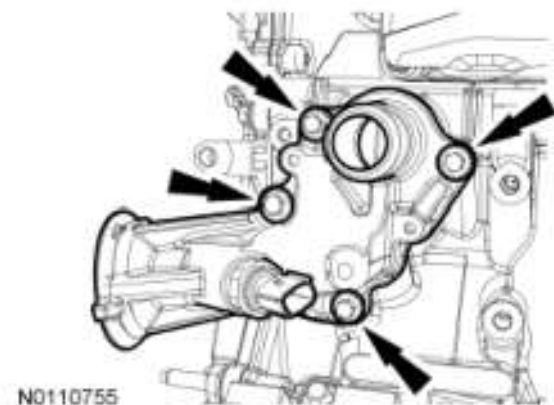

**Fig. 312: Locating Oil Filter Adapter Bolts**  
Courtesy of FORD MOTOR CO.

30. Remove the 6 bolts, coolant pump pulley and the 2 accessory drive belt idler pulleys.

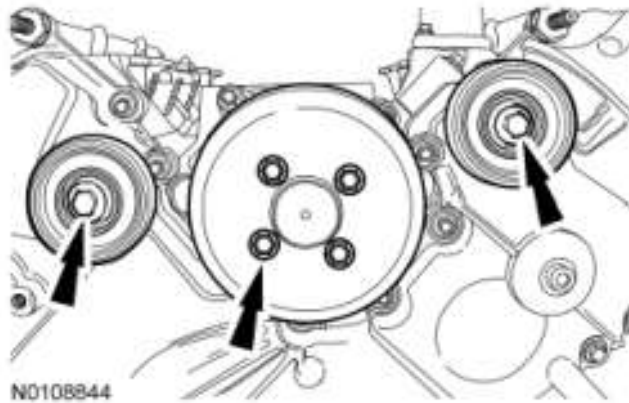

**Fig. 313: Locating Bolts, Coolant Pump Pulley And Accessory Drive Belt Idler Pulleys**  
 Courtesy of FORD MOTOR CO.

31. Remove the 3 bolts and the accessory drive belt tensioner.

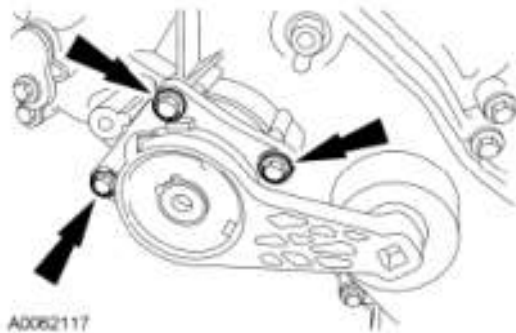

**Fig. 314: Identifying Accessory Drive Belt Tensioner Bolts**  
 Courtesy of FORD MOTOR CO.

32. Remove the 4 bolts and the coolant pump from the cylinder block.
  - Discard the O-ring seal.

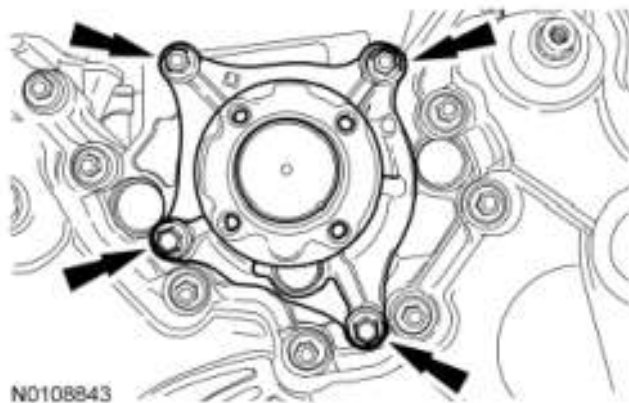

**Fig. 315: Locating Coolant Pump Bolts**  
 Courtesy of FORD MOTOR CO.

33. Remove and discard the crankshaft pulley bolt. Using the 3 Jaw Puller, remove the crankshaft pulley.

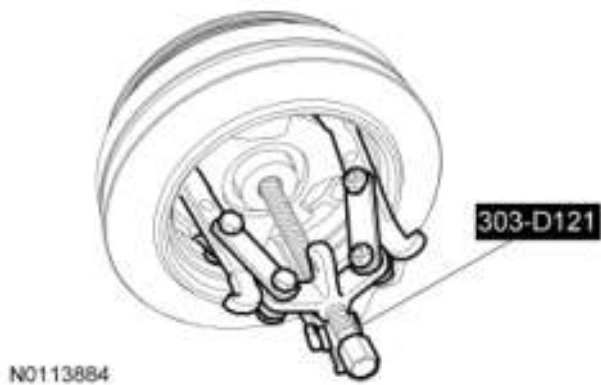

**Fig. 316: Removing Crankshaft Pulley Using Jaw Puller**  
 Courtesy of FORD MOTOR CO.

34. Using the Crankshaft Front Oil Seal Remover, remove and discard the crankshaft seal.

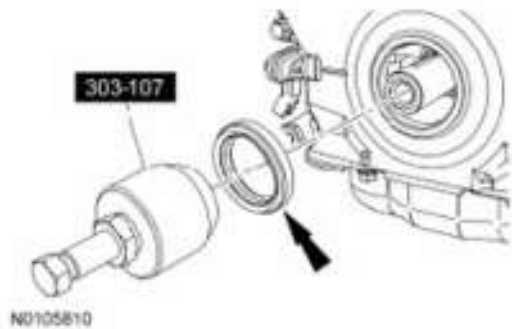
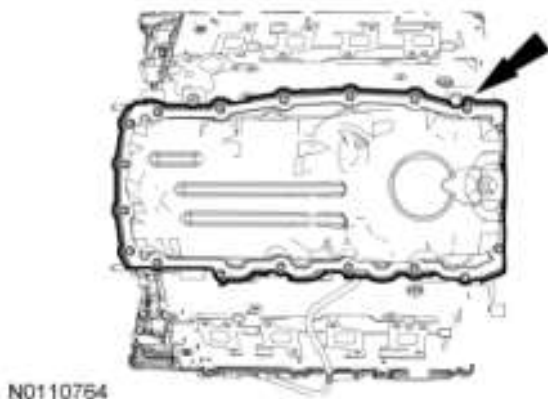

**Fig. 317: Locating Crankshaft Front Seal**  
 Courtesy of FORD MOTOR CO.

35. Remove the 20 bolts, oil pan and oil pan gasket.

**NOTE:** Do not use metal scrapers, wire brushes, power abrasive discs or other abrasive means to clean the sealing surfaces. These tools cause scratches and gouges, which make leak paths. Use a plastic scraping tool to remove all traces of old sealant.

Clean and inspect the sealing surfaces.



**Fig. 318: Inspecting Oil Pan Sealing Surfaces**



Courtesy of FORD MOTOR CO.

**NOTE:** Do not use metal scrapers, wire brushes, power abrasive discs or other abrasive means to clean the sealing surfaces. These tools cause scratches and gouges, which make leak paths. Use a plastic scraping tool to remove all traces of old sealant.

36.

Remove the 8 bolts and the crankshaft rear seal retainer plate.

- Clean and inspect the sealing surfaces.

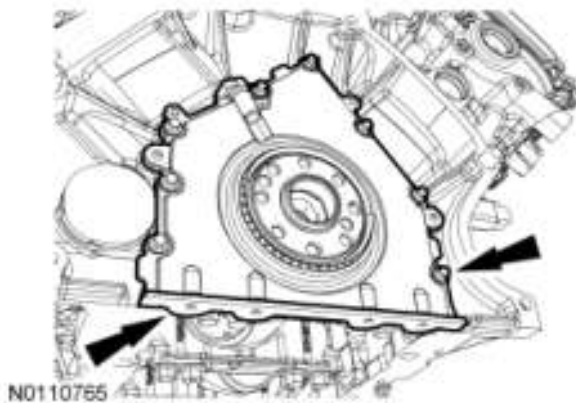
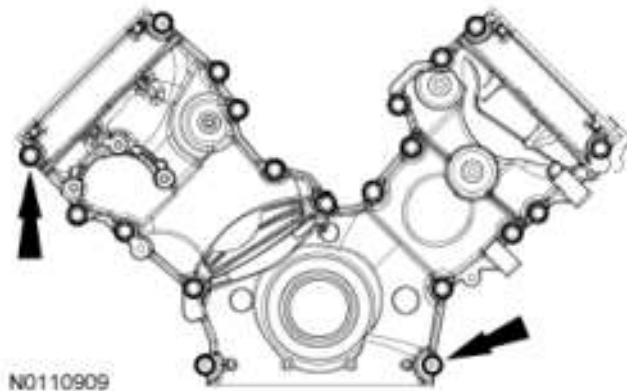

**Fig. 319: Locating Bolts And Crankshaft Rear Seal Retainer Plate**  
Courtesy of FORD MOTOR CO.

**NOTE:** Correct fastener location is essential for assembly procedure. Record fastener location.

37.

Remove the 17 bolts and the 3 studs.



**Fig. 320: Locating Engine Front Cover Bolts And Studs**  
Courtesy of FORD MOTOR CO.

38. Remove the engine front cover from the front cover-to-cylinder block dowel.
- Remove and discard the engine front cover gaskets.

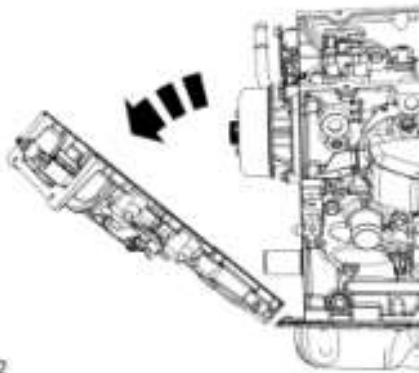

N0113962

**Fig. 321: Removing Engine Front Cover From Front Cover-To-Cylinder Block Dowel**  
Courtesy of FORD MOTOR CO.

39. Rotate the engine clockwise until the No. 1 intake valve is open.
40. Remove the 10 bolts and the LH intake rocker arm shaft assembly.

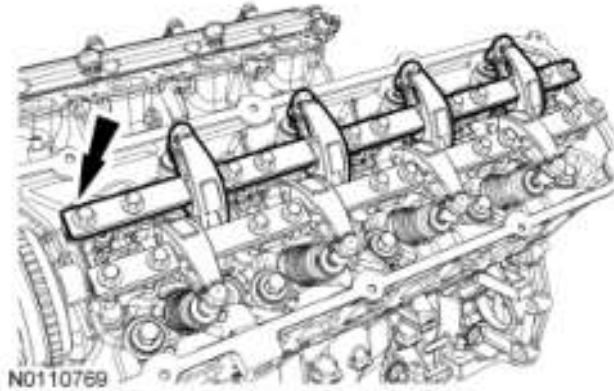

N0110769

**Fig. 322: Locating LH Intake Rocker Arm Shaft Assembly Bolts**  
Courtesy of FORD MOTOR CO.

41. Rotate the engine clockwise until the No. 1 exhaust valve is open.
42. Remove the 10 bolts and the LH exhaust rocker arm shaft assembly.

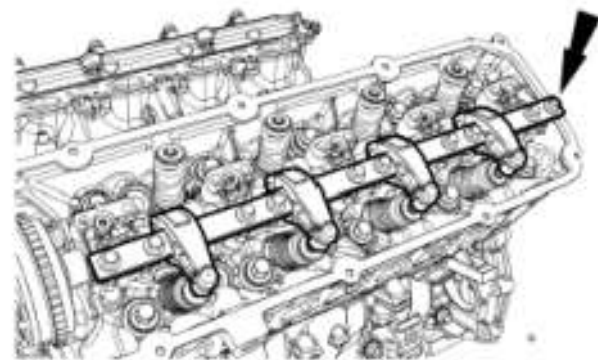

N0110774

**Fig. 323: Locating LH Exhaust Rocker Arm Shaft Assembly Bolts**  
Courtesy of FORD MOTOR CO.

43. Rotate the engine clockwise until the No. 1 intake valve is closed.
44. Remove the 10 bolts and the RH intake rocker arm shaft assembly.

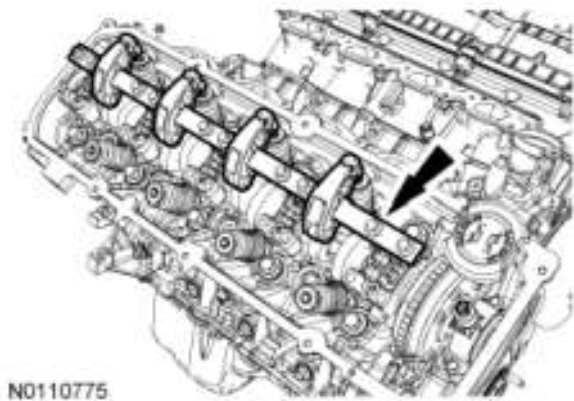

**Fig. 324: Locating RH Intake Rocker Arm Shaft Assembly Bolts**  
Courtesy of FORD MOTOR CO.

45. Rotate the engine clockwise until the No. 1 exhaust valve is closed.
46. Remove the 10 bolts and the RH exhaust rocker arm shaft assembly.

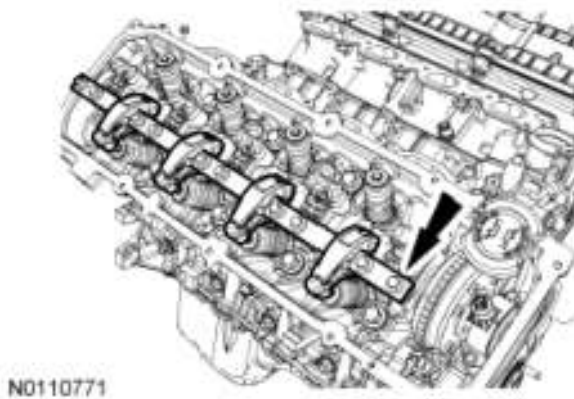

**Fig. 325: Locating RH Exhaust Rocker Arm Shaft Assembly Bolts**  
Courtesy of FORD MOTOR CO.

47. Position the crankshaft keyway at the 11 o'clock position.

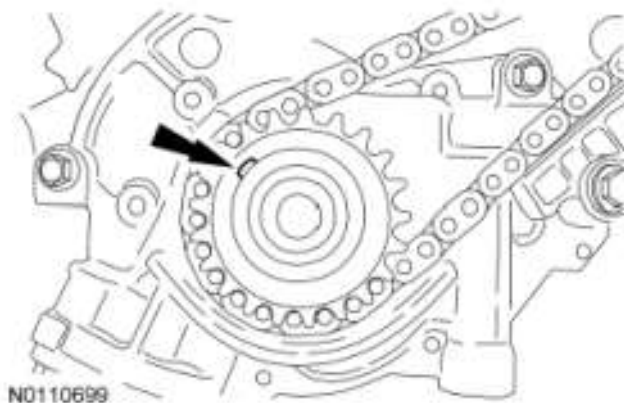

**Fig. 326: Positioning Crankshaft Keyway At 11 O'Clock Position**  
Courtesy of FORD MOTOR CO.

48. Remove the 2 bolts, the RH timing chain tensioner and tensioner arm.

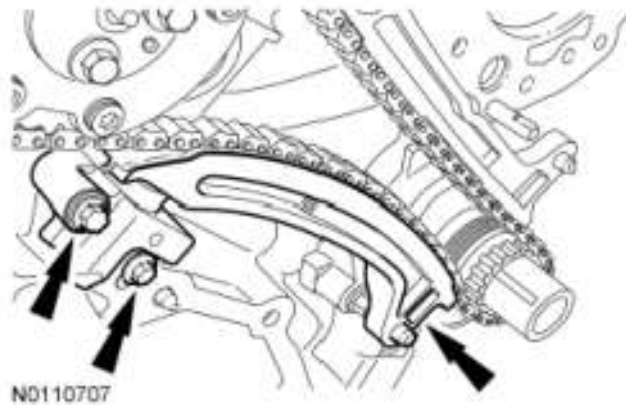

**Fig. 327: Locating Bolts, RH Timing Chain Tensioner And Tensioner Arm**  
Courtesy of FORD MOTOR CO.

49. Remove the bolt and the RH timing chain guide.

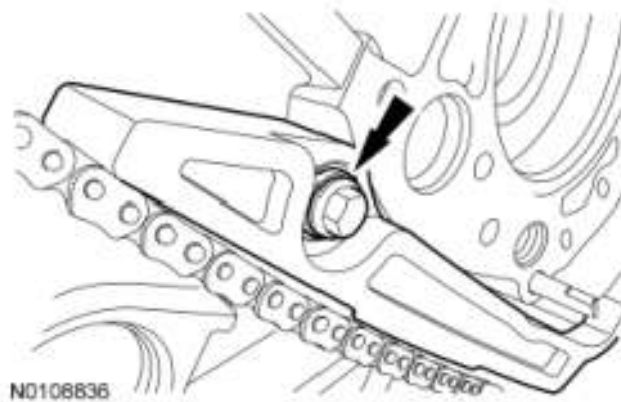

**Fig. 328: Locating RH Timing Chain Guide Bolt**  
Courtesy of FORD MOTOR CO.

50. Remove the RH timing chain.

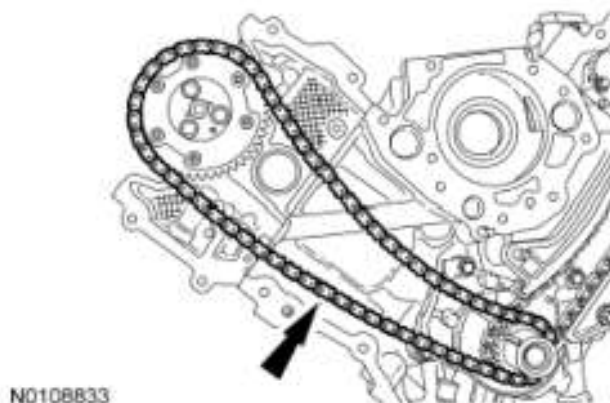

**Fig. 329: Locating RH Timing Chain**  
Courtesy of FORD MOTOR CO.

51. Remove the 2 bolts and the LH timing chain tensioner.

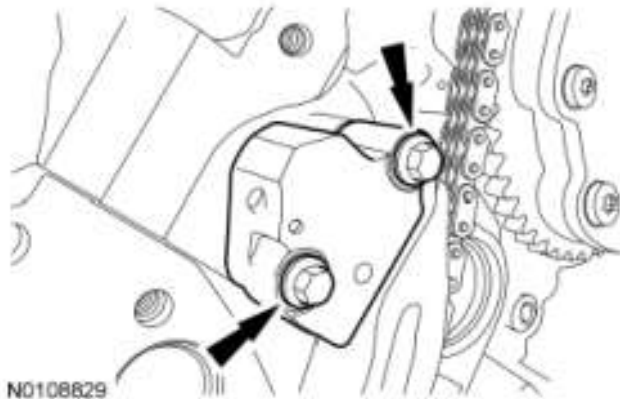

**Fig. 330: Locating LH Timing Chain Tensioner Bolts**  
Courtesy of FORD MOTOR CO.

52. Remove the LH timing chain tensioner arm.

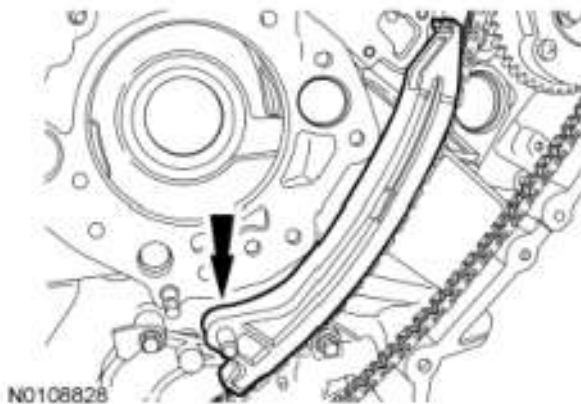

**Fig. 331: Locating LH Timing Chain Tensioner Arm**  
Courtesy of FORD MOTOR CO.

53. Remove the bolt and the LH timing chain guide.



**Fig. 332: Locating Bolt And LH Timing Chain Guide**  
Courtesy of FORD MOTOR CO.

54. Remove the LH timing chain.

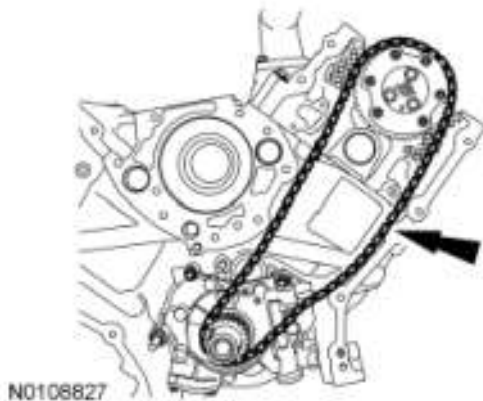

**Fig. 333: LH Timing Chain**  
Courtesy of FORD MOTOR CO.

55. Remove the crankshaft sprocket.

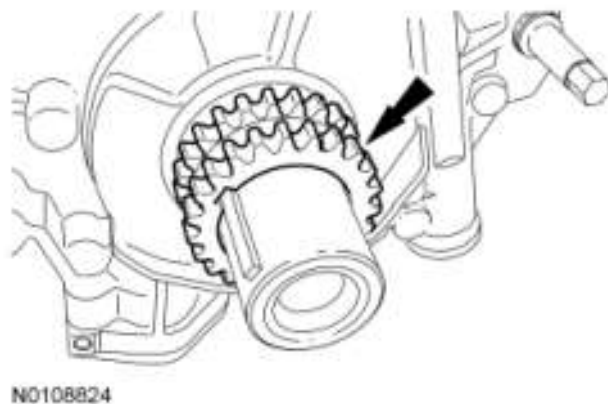

**Fig. 334: Locating Crankshaft Sprocket**  
Courtesy of FORD MOTOR CO.

56. **NOTE:** The cylinder head must be cool before removing it from the engine. Cylinder head warpage may result if a warm or hot cylinder head is removed.
- NOTE:** Place clean shop towels over exposed engine cavities. Carefully remove the towels so foreign material is not dropped into the engine. Failure to follow this instruction may cause engine damage.
- NOTE:** The cylinder head bolts must be discarded and new bolts must be installed. They are a tighten-to-yield design and cannot be reused.
- NOTE:** Do not use metal scrapers, wire brushes, power abrasive discs or other

abrasive means to clean the sealing surfaces. These tools cause scratches and gouges, which make leak paths. Use a plastic scraping tool to remove all traces of old sealant.

**NOTE:** Aluminum surfaces are soft and can be scratched easily. Never place the cylinder head gasket surface, unprotected, on a bench surface. Failure to follow this instruction may cause engine damage.

Remove the 10 bolts and the RH cylinder head.

- Discard the cylinder head gasket.
- Discard the cylinder head bolts.

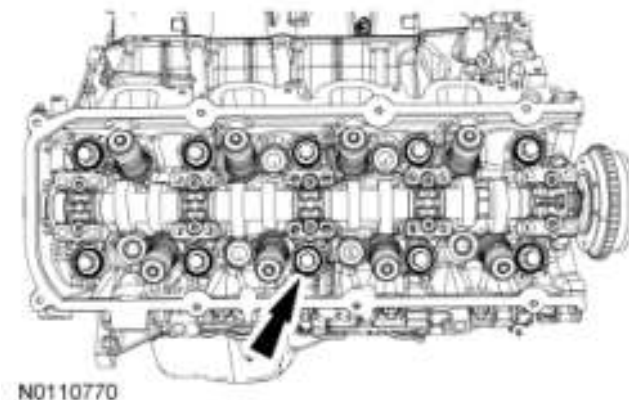

**Fig. 335: Locating RH Cylinder Head Bolts**  
Courtesy of FORD MOTOR CO.

57.

**NOTE:** The cylinder head must be cool before removing it from the engine. Cylinder head warpage may result if a warm or hot cylinder head is removed.

**NOTE:** Place clean shop towels over exposed engine cavities. Carefully remove the towels so foreign material is not dropped into the engine. Failure to follow this instruction may cause engine damage.

**NOTE:** The cylinder head bolts must be discarded and new bolts must be installed. They are a tighten-to-yield design and cannot be reused.

**NOTE:** Do not use metal scrapers, wire brushes, power abrasive discs or other abrasive means to clean the sealing surfaces. These tools cause scratches and gouges, which make leak paths. Use a plastic scraping tool to remove all traces of old sealant.

**NOTE:** Aluminum surfaces are soft and can be scratched easily. Never place the cylinder head gasket surface, unprotected, on a bench surface. Failure to follow this instruction may cause engine damage.

Remove the 10 bolts and the LH cylinder head.

- Discard the cylinder head gasket.
- Discard the cylinder head bolts.

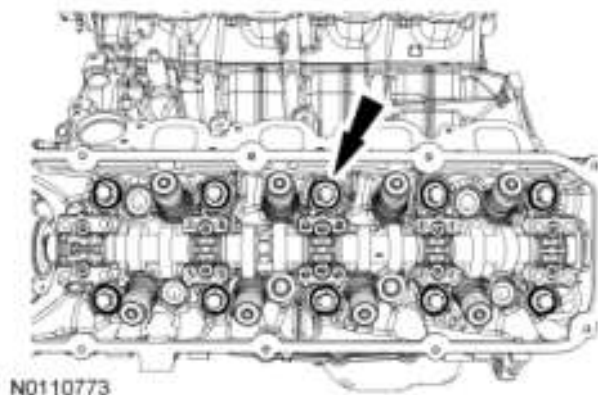

**Fig. 336: Locating LH Cylinder Head Bolts**  
Courtesy of FORD MOTOR CO.

58.

**NOTE:** Do not use metal scrapers, wire brushes, power abrasive discs or other abrasive means to clean the sealing surfaces. These tools cause scratches and gouges, which make leak paths. Use a plastic scraping tool to remove all traces of old sealant.

**NOTE:** Observe all warnings or cautions and follow all application directions contained on the packaging of the silicone gasket remover and the metal surface prep. Failure to follow this procedure may cause engine damage.

**NOTE:** If there is no residual gasket material present, metal surface prep can be used to clean and prepare the surfaces.

Clean the cylinder head-to-cylinder block mating surfaces of both the cylinder head and the cylinder block.

1. Remove any large deposits of silicone or gasket material with a plastic scraper.
  2. Apply silicone gasket remover, following package directions, and allow to set for several minutes.
  3. Remove the silicone gasket remover with a plastic scraper. A second application of silicone gasket remover may be required if residual traces of silicone or gasket material remain.
  4. Apply metal surface prep, following package directions, to remove any remaining traces of oil or coolant, and to prepare the surfaces to bond with the new gasket. Do not attempt to make the metal shiny. Some staining of the metal surfaces is normal.
59. Support the cylinder heads on a bench with the head gasket side up. Check the cylinder head distortion and the cylinder block distortion, paying particular attention to the oil pressure feed area. For additional information, refer to **ENGINE SYSTEM - GENERAL INFORMATION -- F150**.
60. Remove the oil pump screen and pickup tube support bracket nut.



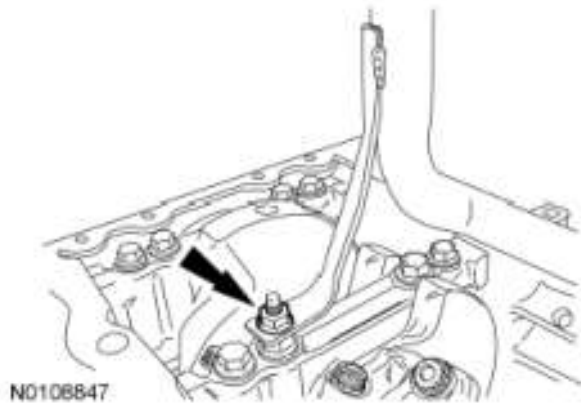

**Fig. 337: Locating Pickup Tube Support Bracket Nut**  
 Courtesy of FORD MOTOR CO.

61. Remove the 2 bolts and the oil pump screen and pickup tube.

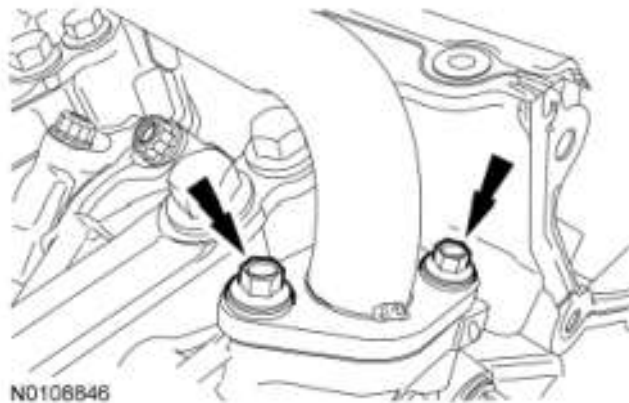

**Fig. 338: Locating Bolts, Oil Pump Screen And Pickup Tube**  
 Courtesy of FORD MOTOR CO.

62. Remove the 2 upper bolts, the 2 lower stud bolts and the oil pump.

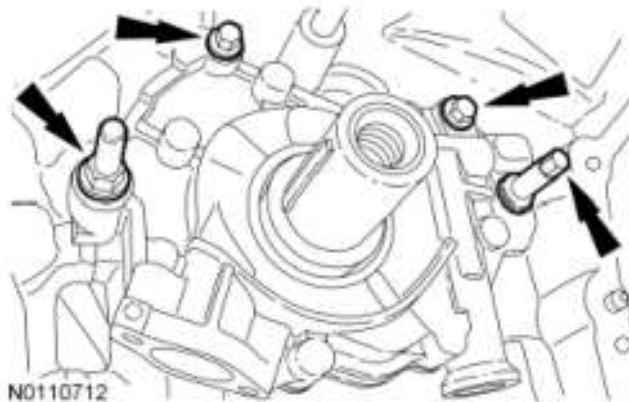

**Fig. 339: Locating Upper Bolts, Lower Stud Bolts And Oil Pump**  
 Courtesy of FORD MOTOR CO.

63. Before removing the pistons, inspect the top of the cylinder bores. If necessary, remove the ridge or carbon deposits from each cylinder using an abrasive pad or equivalent, following the manufacturer

instructions.

**NOTE:** Verify that the connecting rods and rod caps have orientation numbers cast into them. If not, number the connecting rods and rod caps for correct orientation. Failure to follow these instructions may result in engine damage.

64.

Remove the 16 bolts and the 8 connecting rod caps and bearings. Discard the bolts.

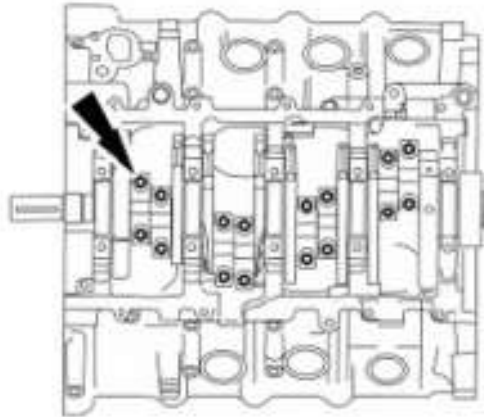

DA0578-A

**Fig. 340: Locating Bolts And Connecting Rod Caps**  
Courtesy of FORD MOTOR CO.

**NOTE:** Do not scratch the cylinder walls or crankshaft journals with the connecting rod. Failure to follow this instruction may result in engine damage.

65.

Use the Connecting Rod Installer to push the piston through the top of the cylinder block.

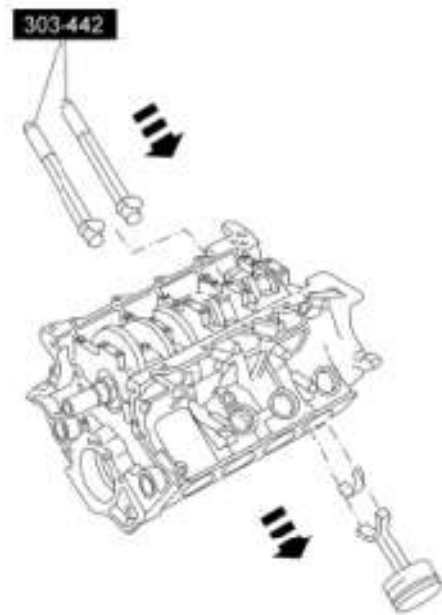

N0010189

**Fig. 341: Pushing Piston Through Top Of Cylinder Block**  
 Courtesy of FORD MOTOR CO.

66. Disassemble the 8 pistons. For additional information, refer to **PISTON**.
  - Inspect the pistons. For additional information, refer to **ENGINE SYSTEM - GENERAL INFORMATION -- F150**.
67. Remove and discard the 10 cross-mounted main cap bolts.
68. **NOTE: Correct stud bolt location is essential for assembly procedure. Record the stud bolt location.**

Remove and discard the 19 main bearing cap bolts and the stud bolt.

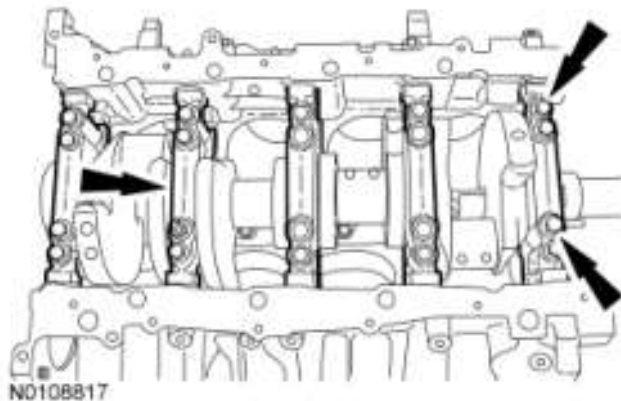

N0108817

**Fig. 342: Locating Main Bearing Cap Bolts And Stud Bolt**  
 Courtesy of FORD MOTOR CO.

69. Remove the main bearing caps, the lower crankshaft main bearings and the lower thrust washer.

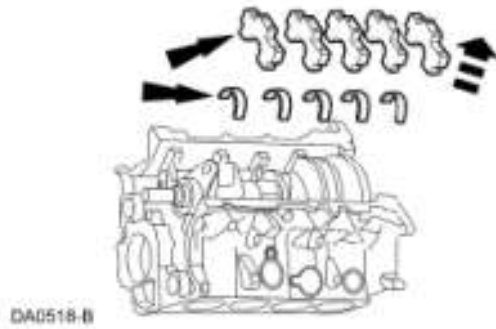

**Fig. 343: Locating Main Bearing Caps, Lower Crankshaft Main Bearings And Lower Thrust Washer**

Courtesy of FORD MOTOR CO.

70. Remove the crankshaft, the upper crankshaft main bearings and the upper thrust washers from the cylinder block.

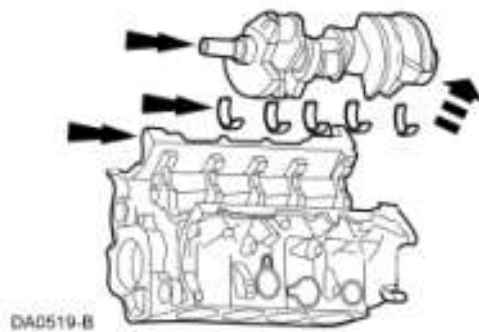

**Fig. 344: Locating Crankshaft, Upper Crankshaft Main Bearings And Upper Thrust Washers**

Courtesy of FORD MOTOR CO.

71. Remove the 4 bolts and the 4 piston oil cooler valves.



**Fig. 345: Locating Bolts And Piston Oil Cooler Valves**

Courtesy of FORD MOTOR CO.

72. Inspect the cylinder block. For additional information, refer to **ENGINE SYSTEM - GENERAL INFORMATION -- F150** .