

GENERAL PROCEDURES

VALVE CLEARANCE ADJUSTMENT

MATERIALS SPECIFICATION

Name	Specification
Motorcraft® SAE 5W-20 Premium Synthetic Blend Motor Oil (U.S.) XO-5W20-QSP (U.S.)	WSS-M2C945-A
Flange Sealant CU7Z-19B508-A	WSS-M2G348-A11

Check

WARNING: Before beginning any service procedure in this service information, refer to health and safety warnings in **GENERAL INFORMATION** . Failure to follow this instruction may result in serious personal injury.

1.

Refer to: **HEALTH AND SAFETY PRECAUTIONS** .

2. Refer to: **VALVE COVER** .

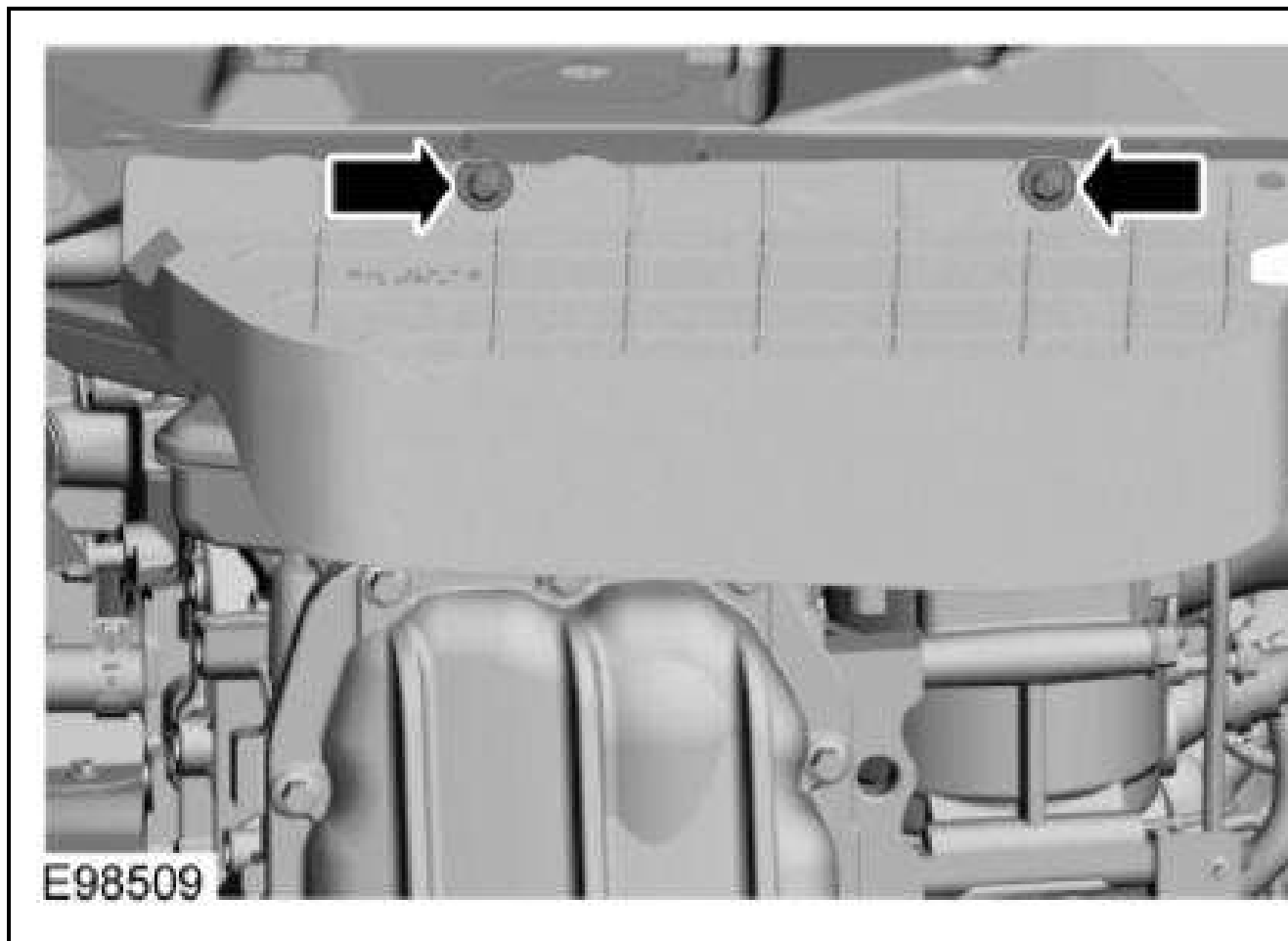

3.

4.

4. **NOTE:** Turn the engine clockwise only and use the crankshaft bolt only.

NOTE: Measure the valve clearance at base circle, with the lobe pointed away from the tappet, before removing the camshafts. Failure to measure all clearances prior to removing the camshafts will necessitate repeated removal and installation and wasted labor time.

Measure each valve's clearance and record its location.

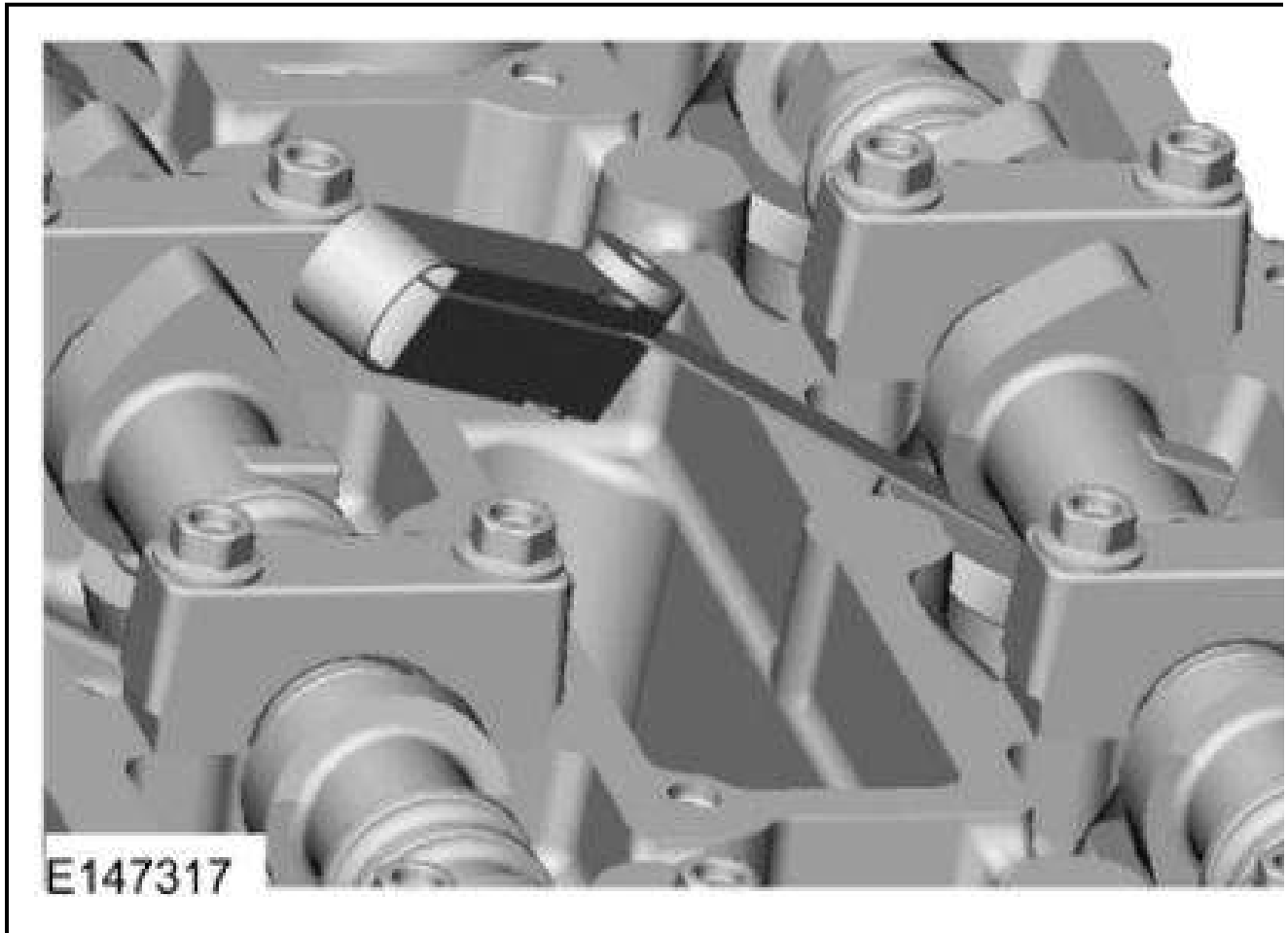

NOTE: The nominal clearance is:

- intake: 0.20 mm (0.0079 in)
 - exhaust: 0.34 mm (0.0133 in)
- 5.

NOTE: The acceptable clearance is:

- intake: 0.17-0.23 mm (0.007-0.009 in)
- exhaust: 0.31-0.37 mm (0.012-0.015 in)

Replace the valve tappets as needed.

Adjustment

1. Refer to: CAMSHAFTS .

NOTE: The number on the valve tappet only reflects the digits that follow the decimal. For example, a tappet with the number 0.650 has the thickness of 3.650 mm.

- 2.

NOTE: Select the closest tappet size to the ideal tappet thickness available and mark the installation location.

Select tappets using this formula: tappet thickness = measured clearance + the existing tappet thickness - nominal clearance.

3. Install the correct valve tappet(s).
4. If necessary.

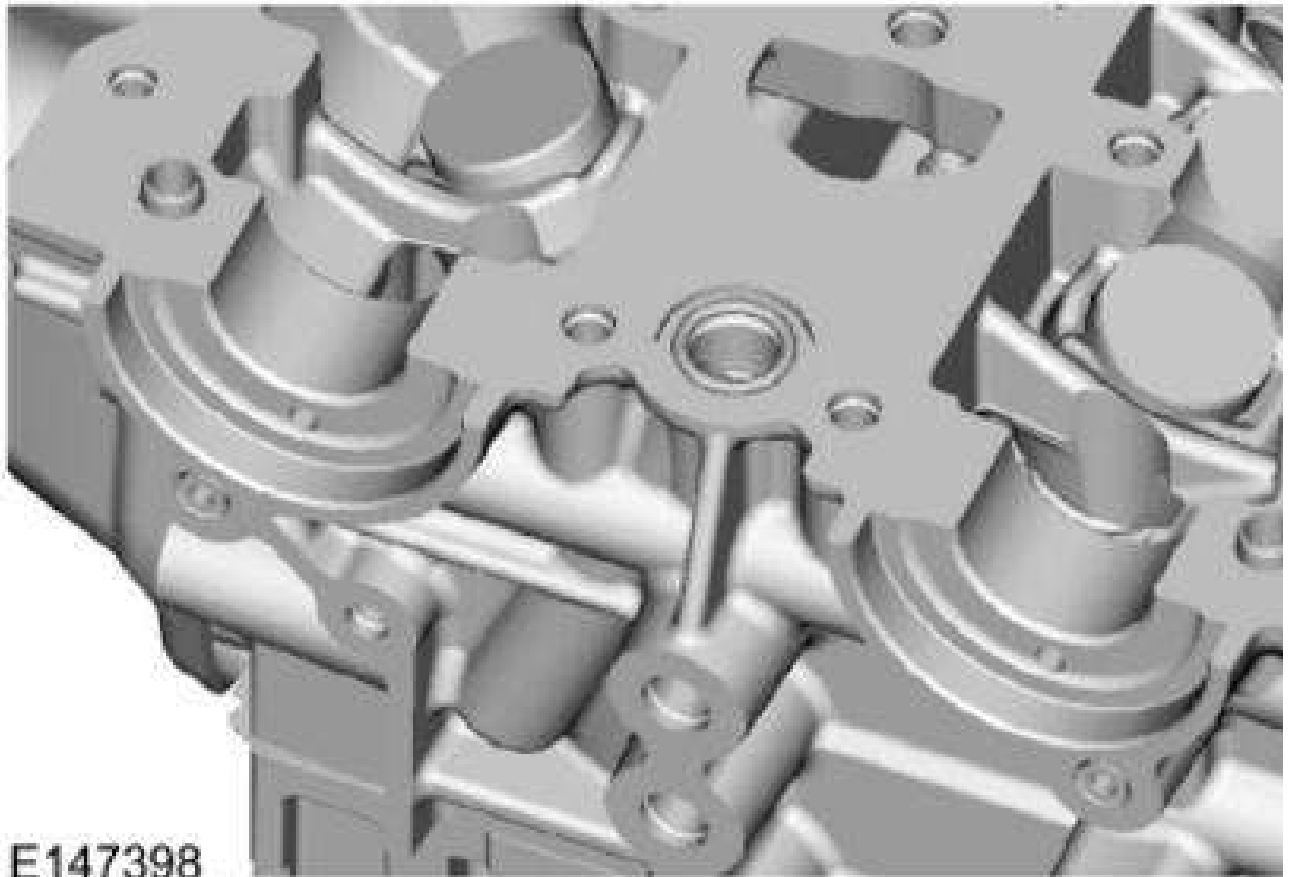

5. *Material:* Motorcraft® SAE 5W-20 Premium Synthetic Blend Motor Oil (U.S.)/XO-5W20-QSP (U.S.) (WSS-M2C945-A)

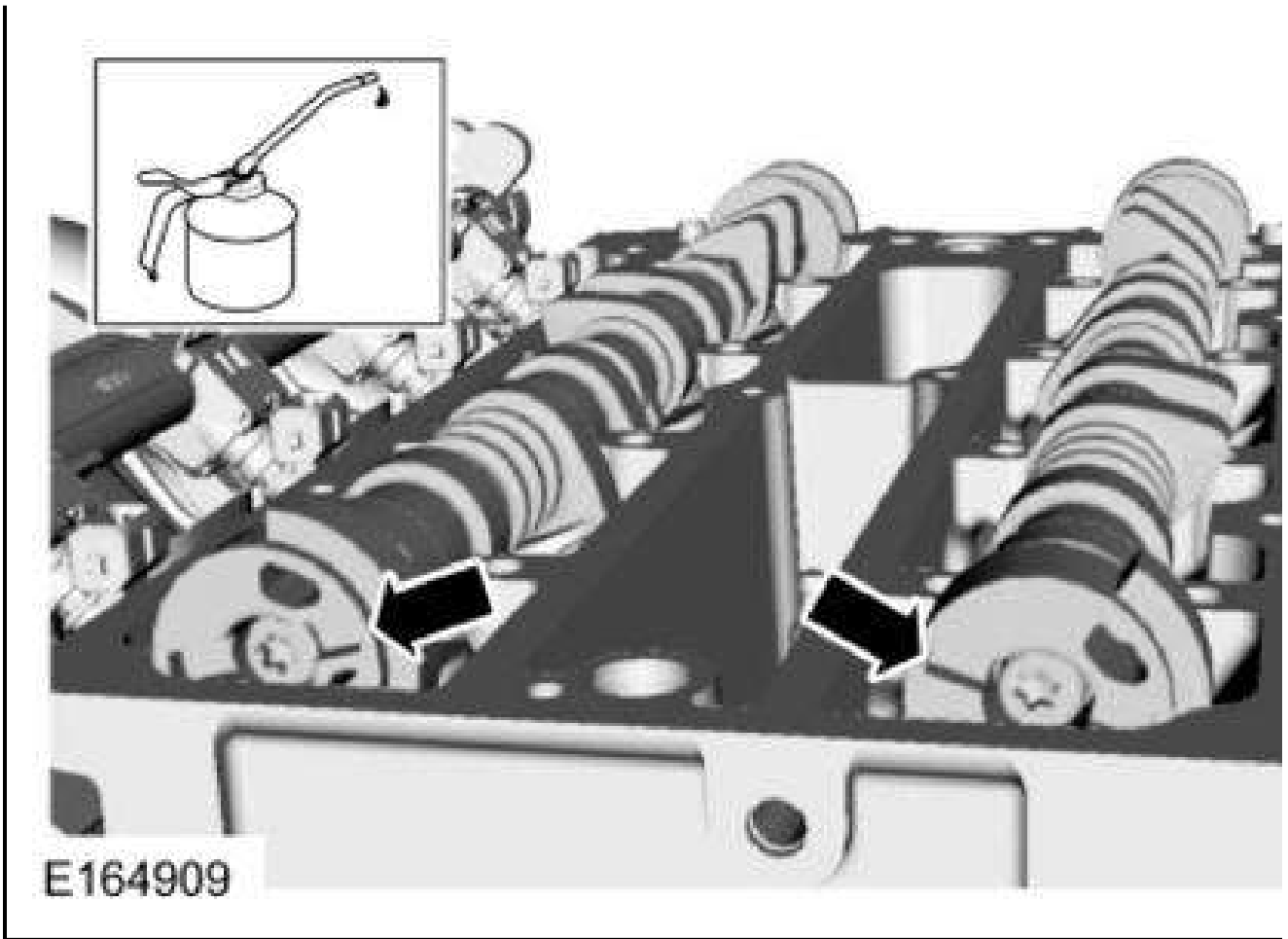

6. *Material:* Flange Sealant/CU7Z-19B508-A (WSS-M2G348-A11)

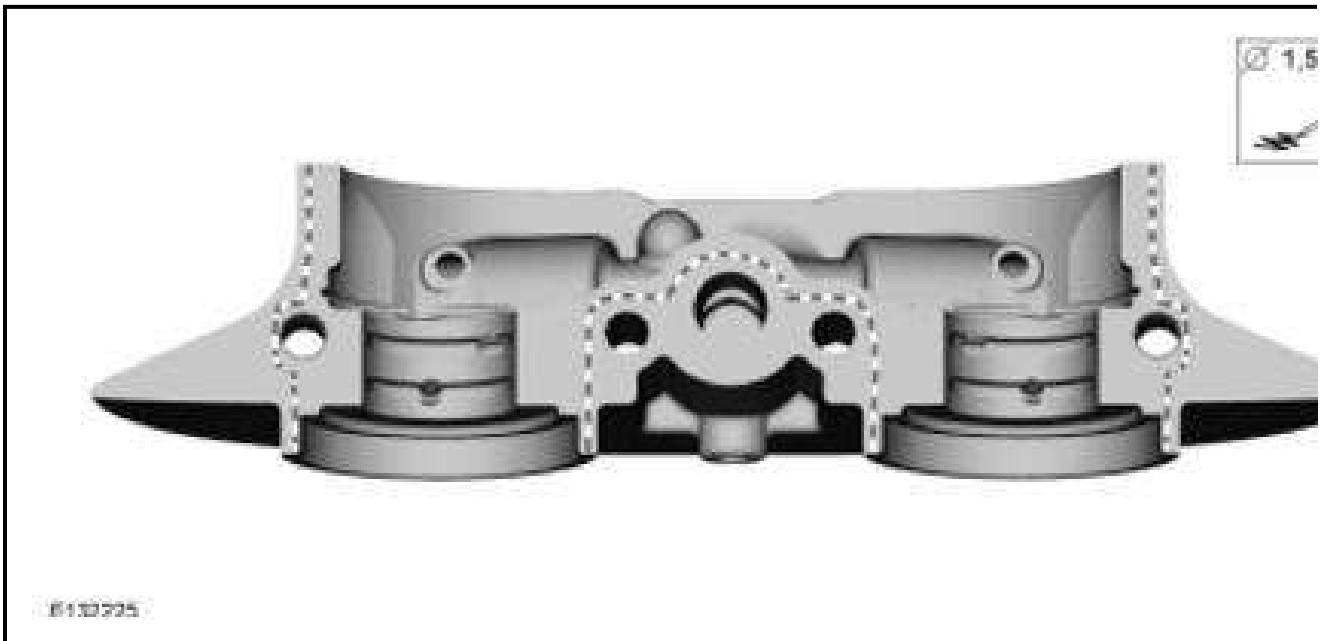

7. Tighten the bolts evenly, half turn at a time, until the crankshaft bearing caps and the VCT bridge are seated against the cylinder head.

Torque :

Stage 1: 1 - 16: 62 lb.in (7 Nm)

Stage 2: 17 - 20: 89 lb.in (10 Nm)

Stage 3: 1 - 16: 45°

Stage 4: 17 and 19: 70°

Stage 5: 18 and 20: 53°

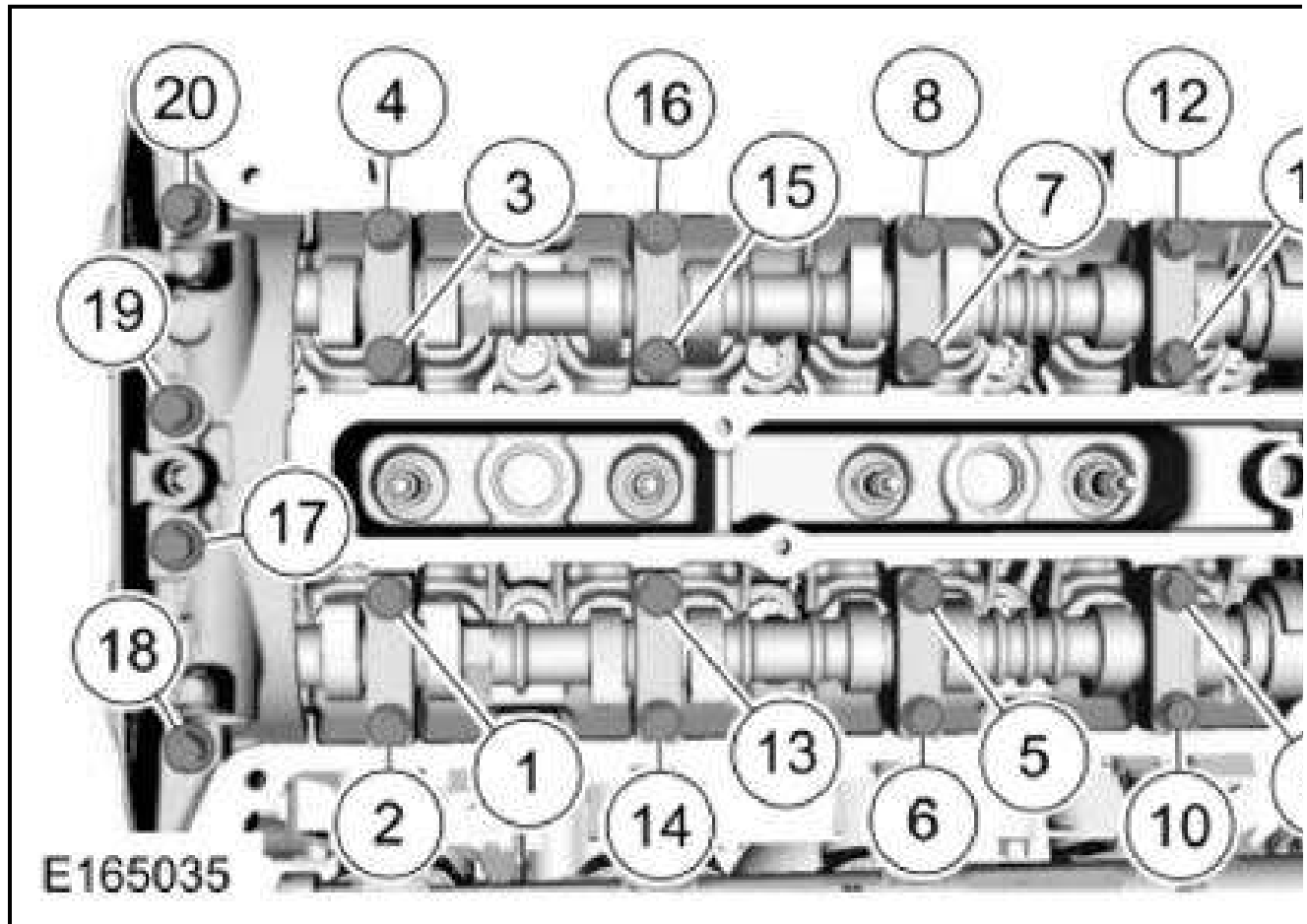

8.

- Turn the crankshaft back by 45° (counterclockwise).
- Turn the camshafts to measure the valve clearance.
- Repeat the procedure as necessary until all the valve clearances are within specifications.
- Turn the crankshaft clockwise until it stops against the special tool.

9. Refer to: **CAMSHAFT SEAL** .

10. *Torque:* 80 lb.in (9 Nm)

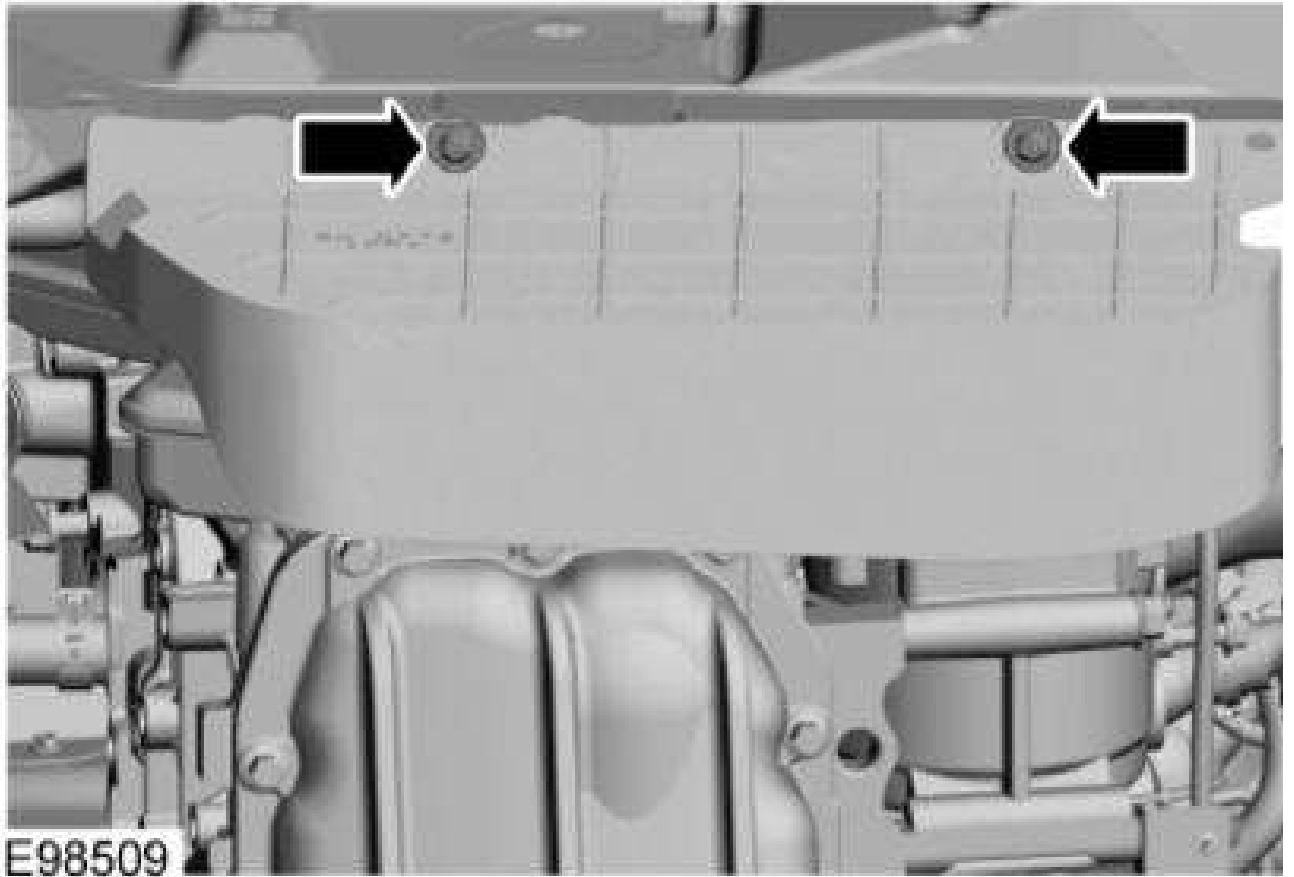

E98509