

DISASSEMBLY AND ASSEMBLY OF SUBASSEMBLIES

FORWARD/OVERDRIVE CLUTCH ASSEMBLY - DISASSEMBLY

Material

MATERIAL SPECIFICATION

Item	Specification
MERCON® SP Automatic Transmission Fluid XT-6-QSP	MERCON® SP

Disassembly & Assembly

1. Remove the direct clutch outer shell retaining ring.

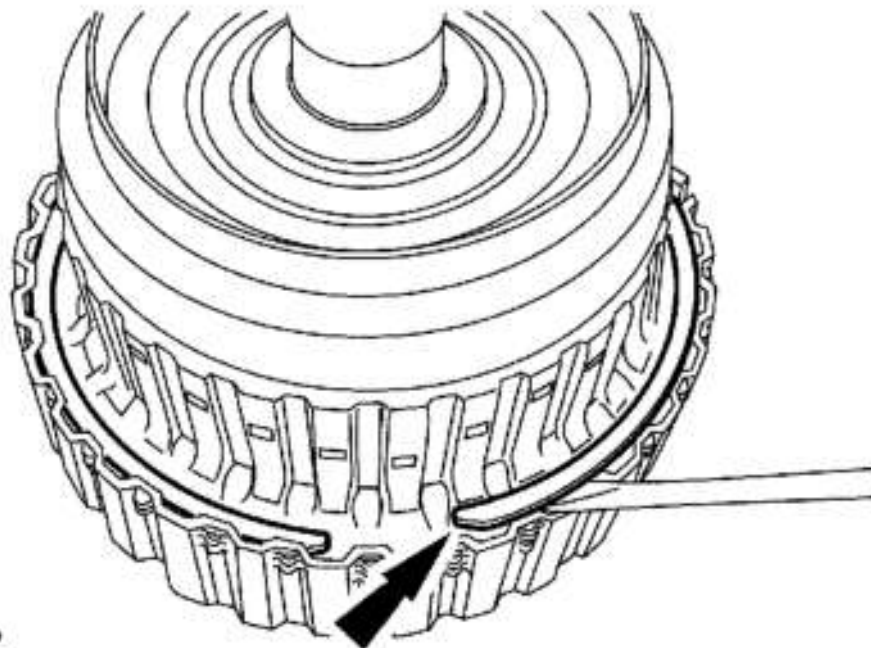
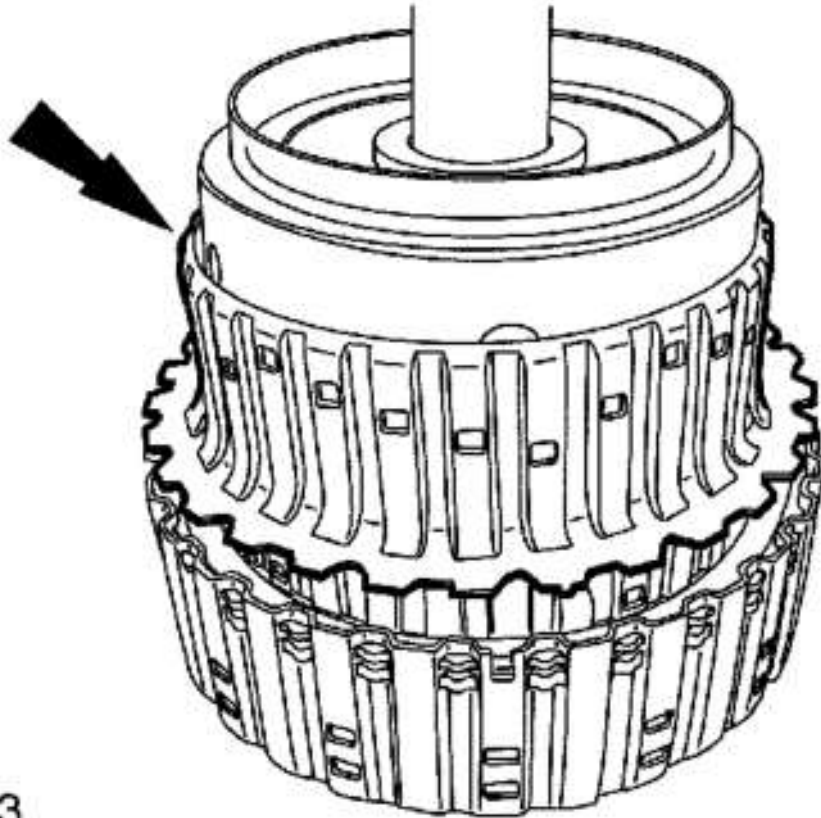

Fig. 188: Removing Direct Clutch Outer Shell Retaining Ring
Courtesy of FORD MOTOR CO.

2. Remove the direct clutch outer shell.



N0005503

Fig. 189: Removing Direct Clutch Outer Shell
Courtesy of FORD MOTOR CO.

3. Remove the forward clutch drum.

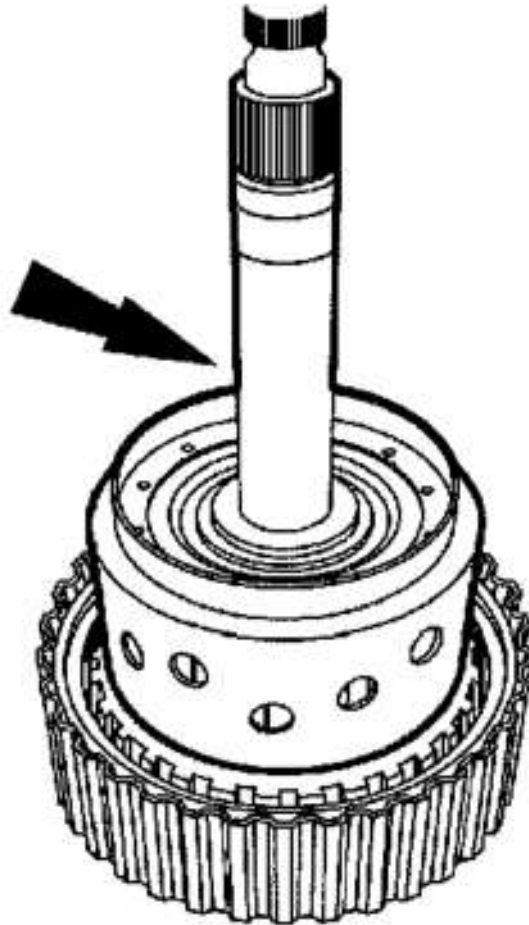

A0088629

Fig. 190: Removing Forward Clutch Drum
Courtesy of FORD MOTOR CO.

NOTE: The bearing may stick in the forward clutch drum.

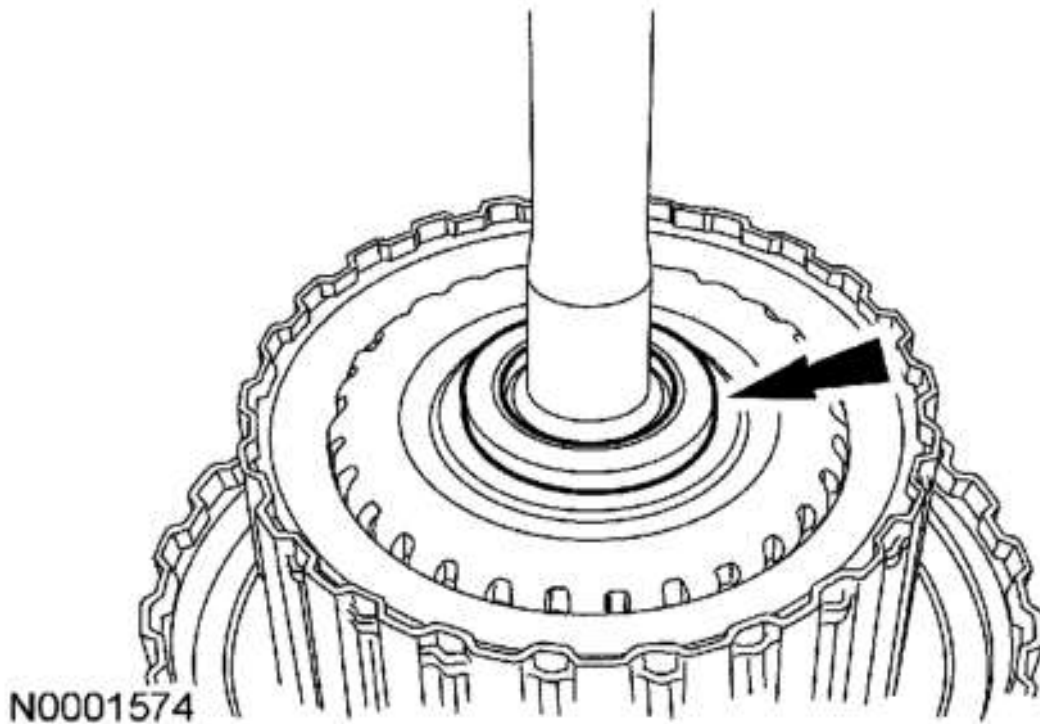

Fig. 191: Removing Intermediate Shaft Bearing
Courtesy of FORD MOTOR CO.

4. Remove the intermediate shaft bearing.
5. Remove the intermediate shaft assembly.

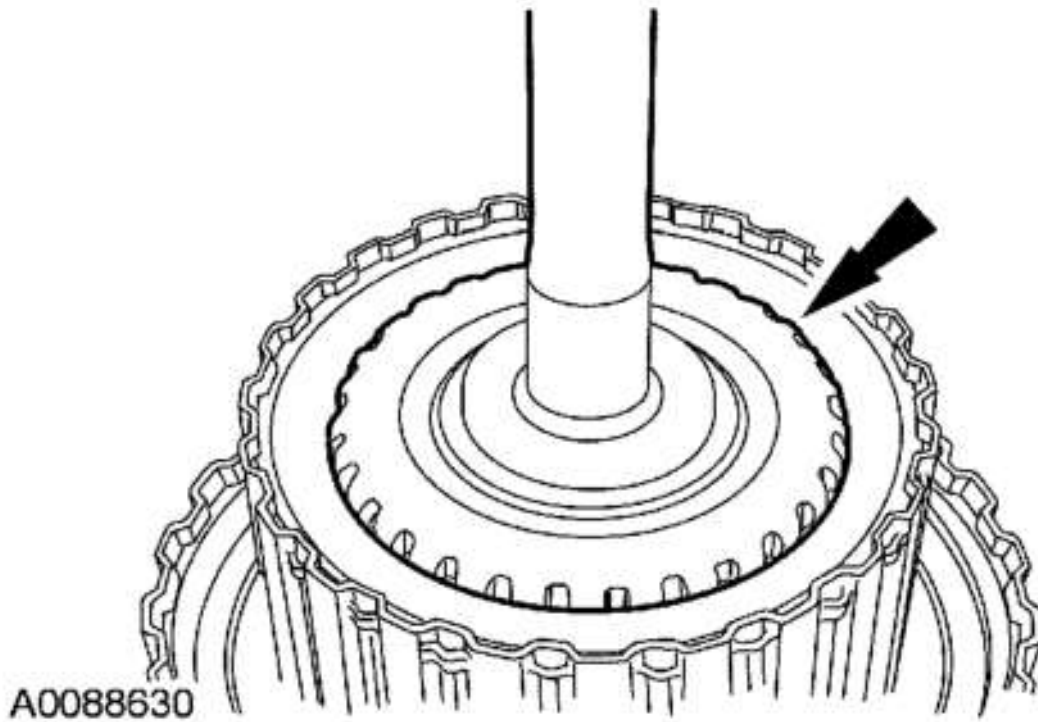
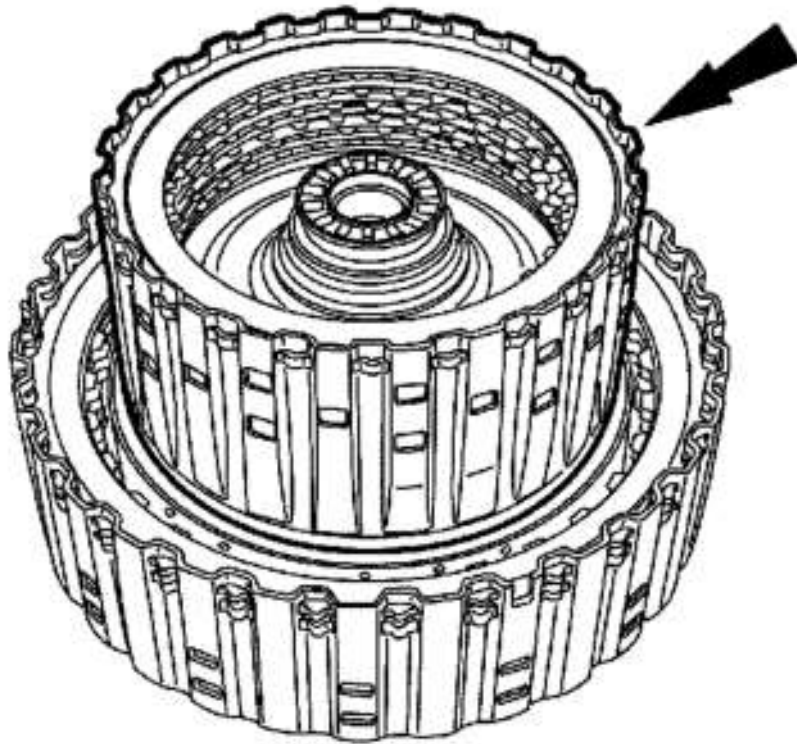

Fig. 192: Removing Intermediate Shaft Assembly
Courtesy of FORD MOTOR CO.

6. Remove the overdrive clutch pack from the forward clutch pack.



N0010203

Fig. 193: Removing Overdrive Clutch Pack
Courtesy of FORD MOTOR CO.

FORWARD CLUTCH ASSEMBLY

Material

MATERIAL SPECIFICATION

Item	Specification
MERCON® SP Automatic Transmission Fluid XT-6-QSP	MERCON® SP

Disassembly

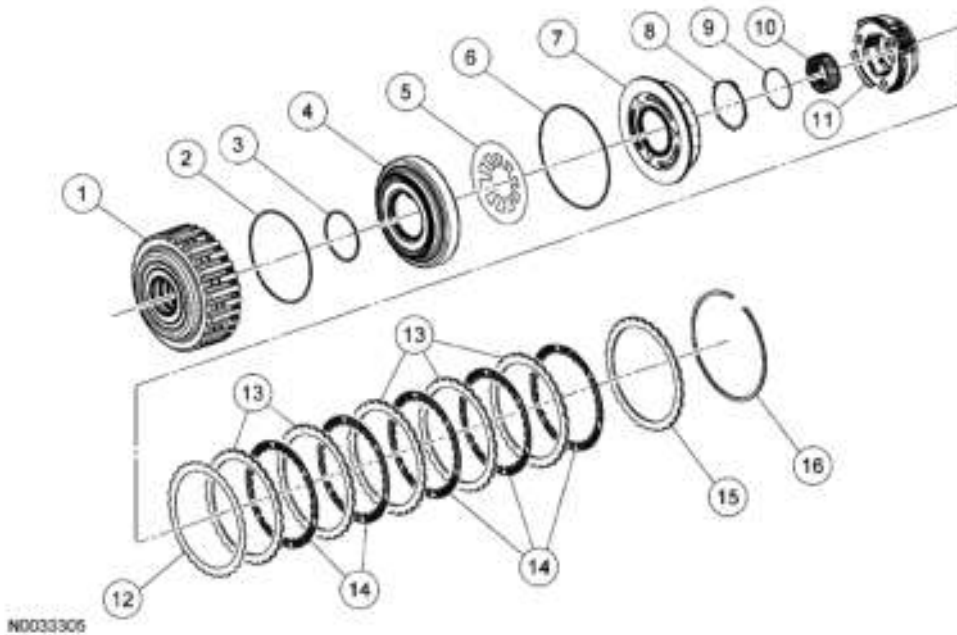

Item	Part Number	Description
1	7J011	Forward clutch drum
2	7F227	Forward clutch piston outer O-ring seal
3	7G242	Forward clutch piston inner O-ring seal
4	7L140	Forward clutch piston
5	7F230	Forward clutch piston return spring
6	7F227	Forward clutch balance dam O-ring seal

Item	Part Number	Description
7	7J032	Forward clutch balance dam
8	—	Forward clutch balance dam retaining ring
9	7H365	Sun gear retaining ring
10	7G231	Sun gear
11	7G219	Planetary gear
12	7E457	Forward clutch wave spring
13	7E314	Forward clutch external splined steel plates (quantity model dependent)
14	7B164	Forward clutch internal splined friction plates (quantity model dependent)
15	—	Forward clutch pressure plate
16	7B421	Forward clutch plate retaining ring

Fig. 194: Exploded View Of Forward Clutch Assembly (A Clutch)
 Courtesy of FORD MOTOR CO.

1. Remove the sun gear from the forward clutch assembly.
 - With a small screwdriver inserted into the sun gear push on the retaining ring in 3 places, while lifting up on the sun gear to remove.

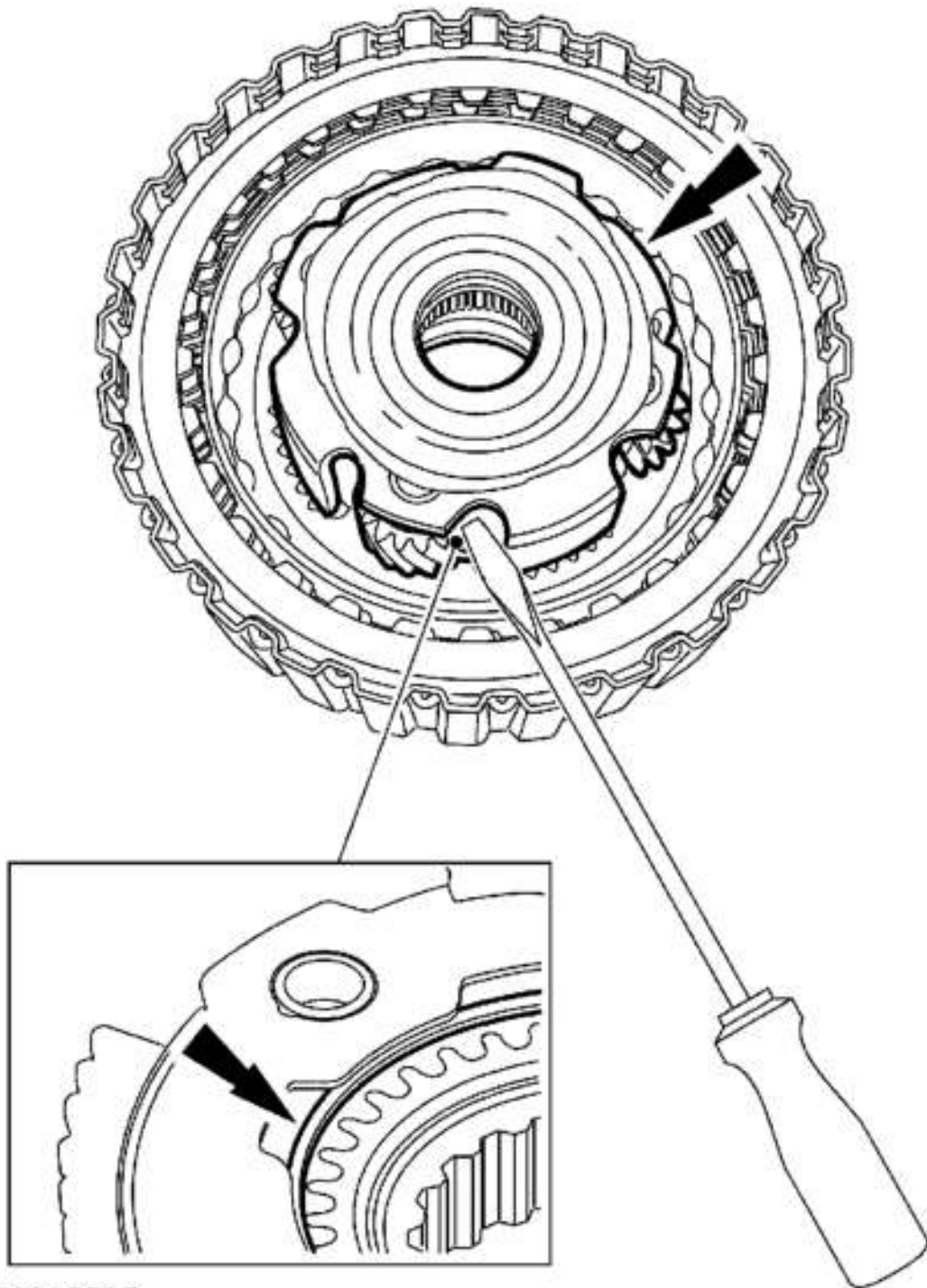

N0005505

Fig. 195: Removing Sun Gear From Forward Clutch Assembly
Courtesy of FORD MOTOR CO.

2. Remove the forward clutch pack snap ring.

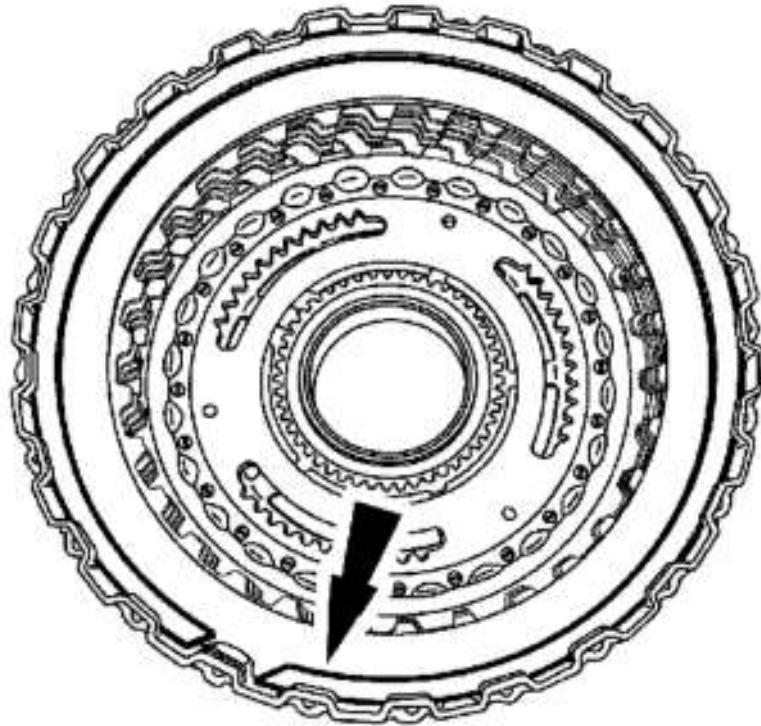

N0001567

Fig. 196: Removing Forward Clutch Pack Snap Ring
Courtesy of FORD MOTOR CO.

NOTE: Inspect the forward clutch drum, friction plates and steel plates for damage. No new components are installed at this time. If new components are required, a new forward clutch assembly is required.

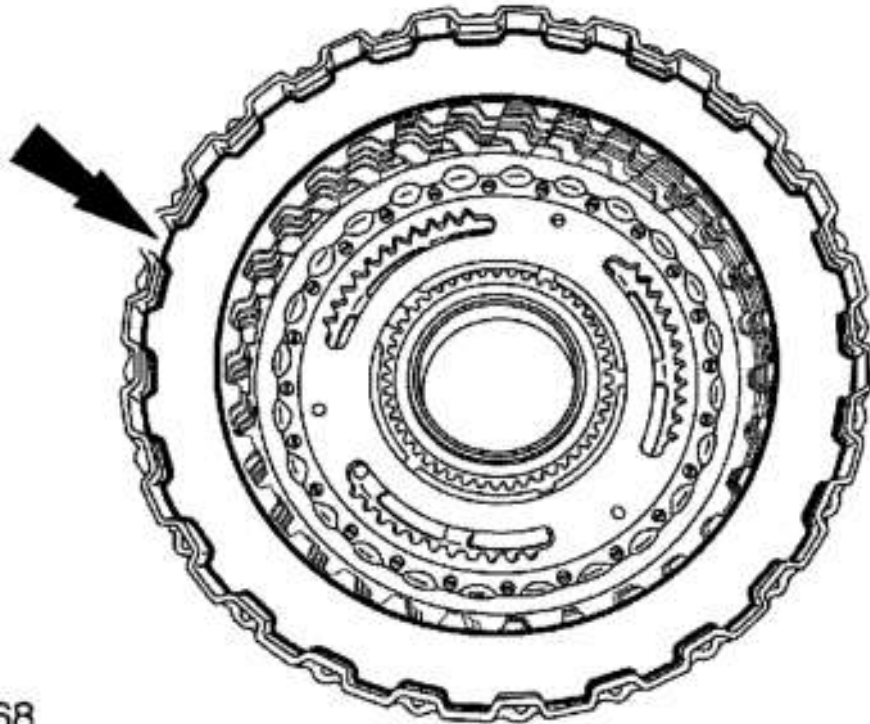

N0001568

Fig. 197: Removing Forward Clutch Plates
Courtesy of FORD MOTOR CO.

3. Remove the forward clutch plates, steel and friction. Inspect the steel and friction plates for damage. If damage is indicated, a new forward clutch assembly will be required.
 - If no damage is indicated the forward clutch can be re-assembled.

Assembly

1. Install the forward clutch plates, starting with the wave spring then a steel plate and alternating between friction and steel plates, and ending up with the pressure plate.

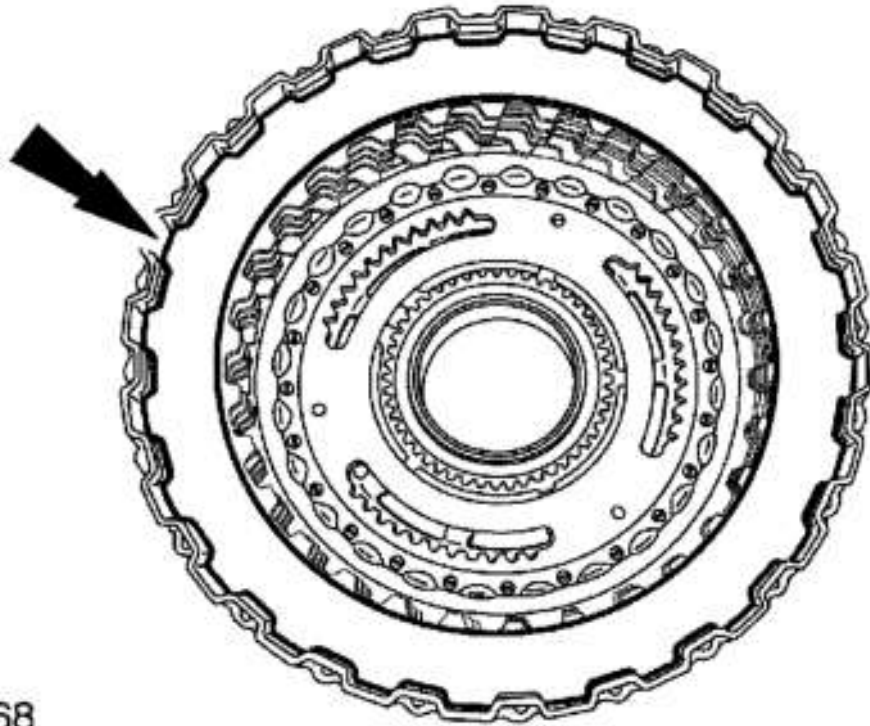

N0001568

Fig. 198: Installing Forward Clutch Plates
Courtesy of FORD MOTOR CO.

2. Install the forward clutch plate snap ring.

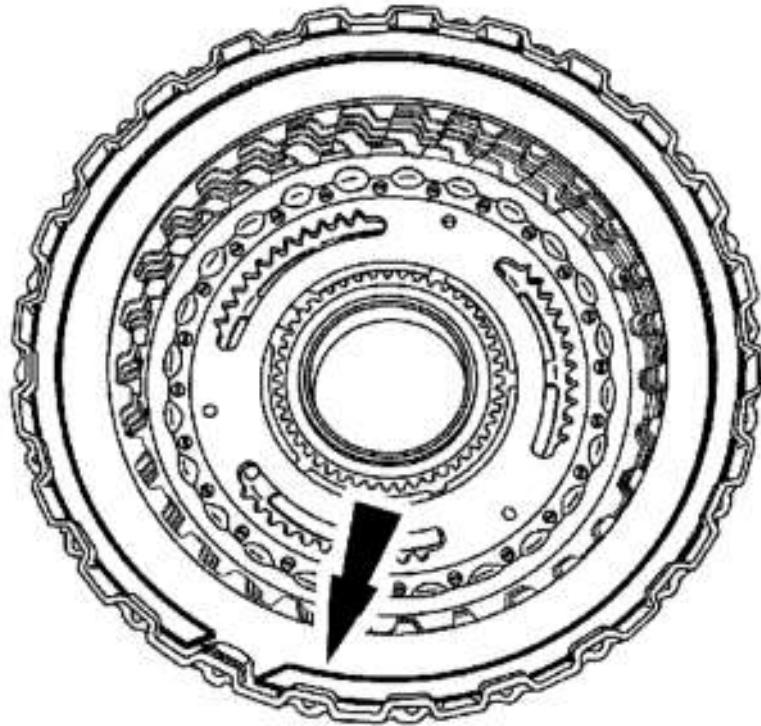

N0001567

Fig. 199: Installing Forward Clutch Plate Snap Ring
Courtesy of FORD MOTOR CO.

3. Install the sun gear into the forward clutch drum. Make sure that it snaps and locks in place.

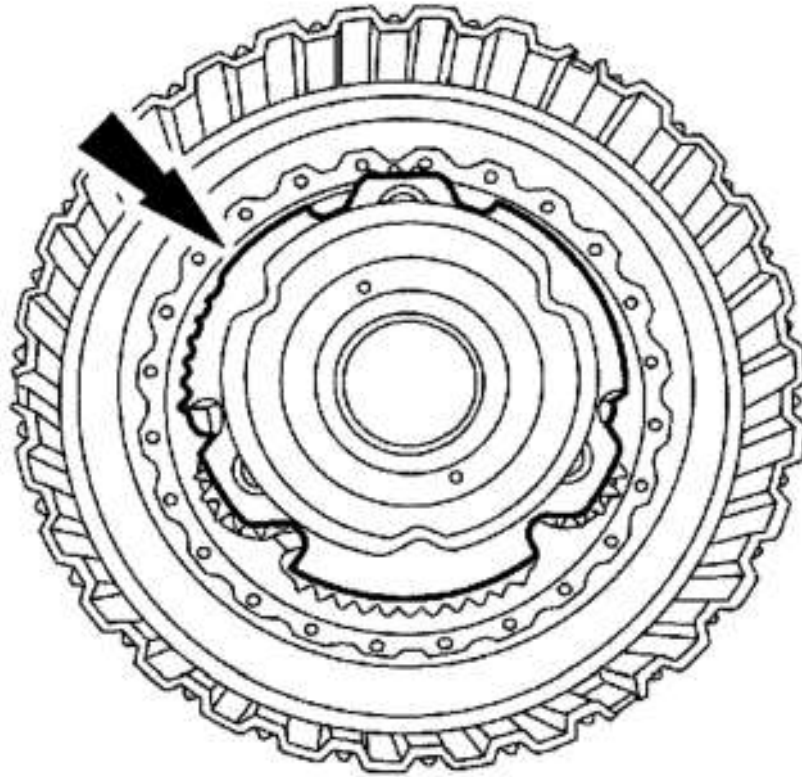

N0005541

Fig. 200: Installing Sun Gear Into Forward Clutch Drum
 Courtesy of FORD MOTOR CO.

OVERDRIVE CLUTCH ASSEMBLY

Material

MATERIAL SPECIFICATION

Item	Specification
MERCON® SP Automatic Transmission Fluid XT-6-QSP	MERCON® SP

Disassembly

NOTE: Overdrive clutch also referred to as E-clutch.

1. Remove the roller bearing. Clean and inspect the roller bearing.
 - If damage is indicated, a new overdrive clutch assembly will be required.

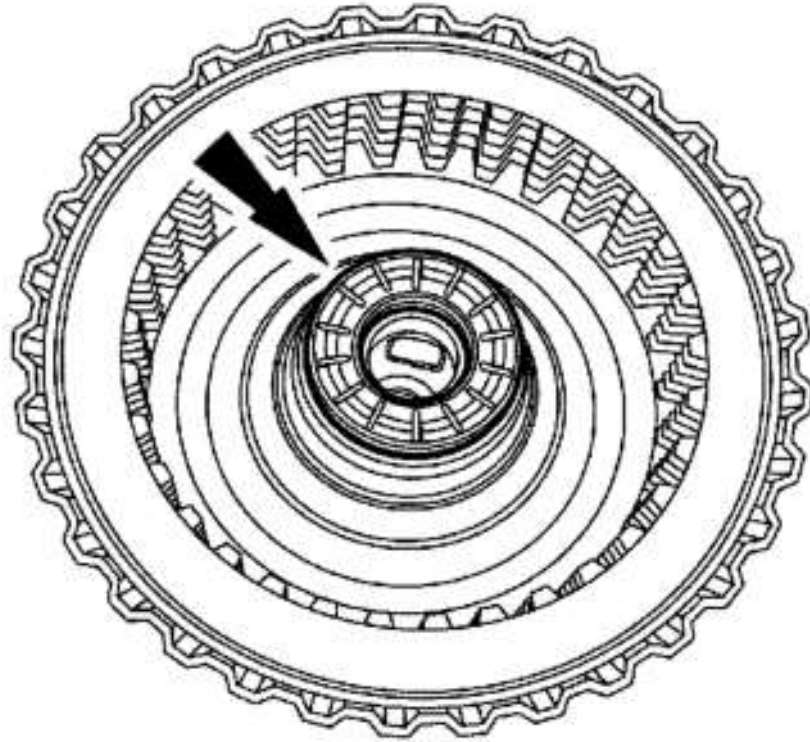

N0005504

Fig. 201: Removing Roller Bearing
Courtesy of FORD MOTOR CO.

2. Remove the overdrive clutch pack snap ring.

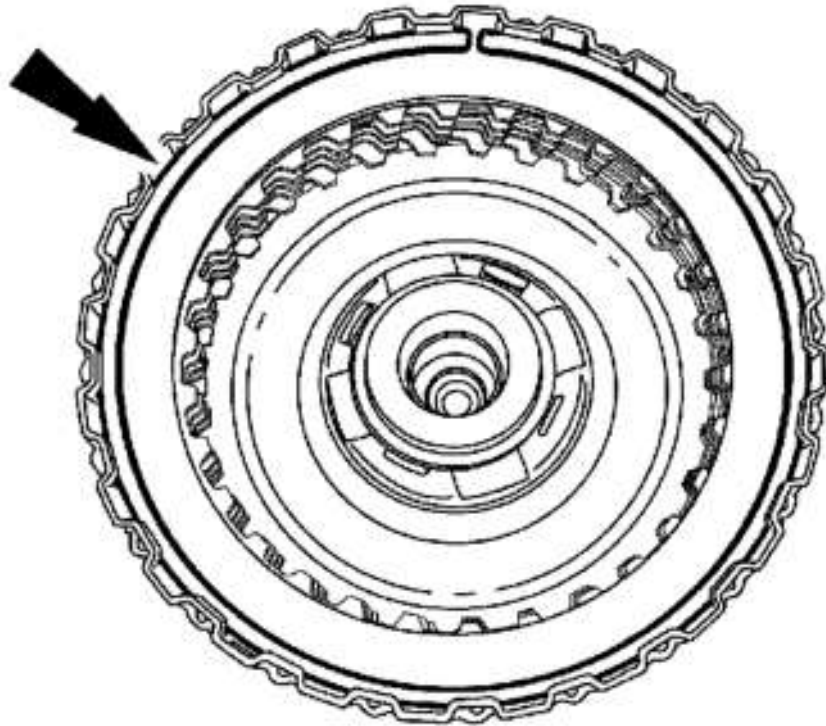

N0001561

Fig. 202: Removing Overdrive Clutch Pack Snap Ring
Courtesy of FORD MOTOR CO.

NOTE: Inspect the overdrive clutch drum, friction plates and steel plates for damage. No new components are installed at this time. If new components are required, a new overdrive clutch assembly is required.

)LJ 5HPRYLQJ 2YHUGULYH &OXWFK 3ODWHV
&RXUWHV\ RI)25' 02725 &2

5HPRYH WKH RYHUGULYH FVXWFK, SUSHW WKWHVOPIDIC
,I GDPDJH LV LQGLFDWHG DEONZZRYGLEHUUHXFQXK DVV
z ,I QR GDPDJH LV LQGLFDWHG WKHRYHBBBHH FOXWFK
,I HTXLSSHG UHPRYH WKHRYHUG&QYBQDXWFKQW&HWW
z ,I GDPDJH LV LQGLFDWHG DEONZZRYGLEHUUHXFQXM

)LJ 5HPRYLQJ 2YHUGULYH &OXWFK 7KUXVW :DVKHU
&RXUWHV\ RI)25' 02725 &2

127(7KH UROOHU EHDULQJ PD\ V\ ~~W&MF~~ ~~WB~~ ~~WIKIP~~ ~~RO~~ \HU

)LJ ,QVSHFWLQJ 6TXDUH &XW 6HDOV
&RXUWHV\ RI)25' 02725 &2

,QVSHFW WKH WKUHH VTXDUH E@WIRH DGDV DQG WKH UROO
z ,I GDPDJH LV LQGLFDWHG DEON ZZ RO@LEGUUMH XFLXMGFK

\$VVHPEO\

,QVWDOO WKH VTXDUH UFLXW VHDOV DQG WKH UROOHU EH

)LJ ,QVWDOOLQJ 6TXDUH &XW 6HDOV
&RXUWHV\ RI)25' 02725 &2

,I UHPRYHG LQVWDOO W ~~DKR~~ MHUGULYH FOXWFK WKUXVW

)LJ _____, QVWDOOLQJ 2YHUGULYH & OXWFK 7KUXVW :DVKHU
&RXUWHV\ RI)25' 02725 &2

, QVWDOO WKH RYHUGULKHWKHXZDFYKHSVOSUWLQV VVWVHQJWLVQVHZ
EHWZHHQ IULFWLRQ DQG VVWVHQJWLVQVHZVWVHQJWLVQVHZVWVHQJWLVQVHZ

)LJ _____, QVWDOOLQJ 2YHUGULYH & OXWFK 3ODWHV
&RXUWHV\ RI)25' 02725 &2

, QVWDOO WKH RYHUGULYH FOXWFK SDFN VQDS ULQJ

)LJ ,QVWDOOLQJ 2YHUGULYH &OXWFK 3DFN 6QDS 5LQ
&RXUWHV\ RI)25' 02725 &2

,QVWDOO WKH UROOHU EHDULQJ

)LJ _____, QVWDOOLQJ 5ROOHU %HDULQJ
&RXUWHV\ RI)25' 02725 &2

)25:\$5' 29(5'5,9(&/87&+ \$66(0%/< \$66(0%/<

0DWHULDO

0\$7(5,\$/ 63(&,),&\$7,21

,WHP	6SHFLILFDWLRQ
0(5&21Š 63 \$XWRPDWLF 7UDQVPLVLRQ)OXLC(5&21Š66Š	

\$VVHPEO\

,QVWDOO WKH RYHUGULYB FOXWFK SDFN RQWR WKH IRUZ

)LJ _____, QVWDOOLQJ 2YHUGULYH & OXWFK 3DFN
&RXUWHV\ RI)25' 02725 &2

,QVWDOO WKH LQWHUPHGLDWH VKDIW DVVHPEO\

)LJ _____, QVWDOOLQJ ,QWHUPHGLDWH 6KDIW \$VVHPEO\
&RXUWHV\ RI)25' 02725 &2

,QVWDOO WKH LQWHUPHGLDWH VKDIW EHDULQJ

)LJ _____, QVWDOOLQJ , QWHUPHGLDWH 6KDIW %HDULQJ
&RXUWHV\ RI)25' 02725 &2

, QVWDOO WKH QHHGOH EMDKLGUXEPQWR WKH RYHUGULYH F

)LJ ,QVWDOOLQJ 1HHGOH&XWFKQWXQWR 2YHUGULYH
&RXUWHV\ RI)25' 02725 &2

,QVWDOO WKH RYHUGULYH FOXWFK GUXP

)LJ ,QVWDOOLQJ 2YHUGULYH &OXWFK 'UXP
&RXUWHV\ RI)25' 02725 &2

,QVWDOO WKH GLUHFV FOXWFK RXWHU VKHOO

)LJ _____, QVWDOOLQJ 'LUHFW &OXWFK 2XWHU 6KHOO
&RXUWHV\ RI)25' 02725 &2

, QVWDOO WKH GLUHFW ~~EOX~~WFK RXWHU VKHOO UHWDLQLQ

)LJ _____, QVWDOOLQJ 'LUHFWLQDQWFKQXWHU 6KHOO 5HWD
&RXUWHV\ RI)25' 02725 &2

',5(&7 &/87&+ \$66(0%/<

0DWHULDO

0\$7(5,\$/ 63(&,),&\$7,21

,WHP	6SHFLILFDWLRQ
0(5&21Š 63 \$XWRPDWLF 7UDQVPLVLRQ)OXLQ(5&21Š66\$	

'LUHFW &OXWFK \$VVHPEO\ % &OXWFK

'LVDVVHPEO\

)LJ ([SORGHG 9LHZ 2I 'LUHF&O&O*WFK \$VVHPEO\ %
&RXUWHV\ RI)25' 02725 &2

,QVSHFW WKH VFDUI FXLQJVHJDO&DPOGHWKH UROOHU EHD
z ,I GDPDJH LV LQGLFDWHG DZLQZGEHUHFHXEOKWFK

)LJ _____, QVSHFWLQJ 6FDUI &XW 6HDOV
&RXUWHV\ RI)25' 02725 &2

5HPRYH WKH XSSHU UROOHU W K B U L P Q O R & O H E D O U L Q G I L R V S G
z , I GDPDJH LV LQGLFDWHG B E O H Z Z R Y G L E G U U Y H X F L O X M F K

)LJ 5HPRYLQJ 8SSHU 5ROOHU %HDULQJ
&RXUWHV\ RI)25' 02725 &2

5HPRYH WKH GLUHFV FOXWFK VQDS ULQJ

)LJ 5HPRYLQJ 'LUHFW &OXWFK 6QDS 5LQJ
&RXUWHV\ RI)25' 02725 &2

127(

,QVSHFW WKH GLUHFV FOXWFOGGVWPHHQ LSFQDLVRIQ
GDPDJH 1R QHZ FRPSRQHQQV DUH, LQVWDOOHG
FRPSRQHQQV DUH UHTXLHG D QHZ GLUHFWUFHQ

)LJ 5HPRYLQJ 'LUHFW &OXWFK 3ODWHV
&RXUWHV\ RI)25' 02725 &2

5HPRYH WKH GLUHFV FORWFKQSSEIWW WKHW MWOHDOO BQQGLIFU
GDPDJH LV LQGLFDWHG D QHZOGELW HUFW XFLOXMGFK DVVHPEO
z ,I QR GDPDJH LV LQGLFDWHG D WKVHEOEOMHGW FOXWFK F

\$VVHPEO\

,QVWDOO WKH GLUHFV KIOZDFK SODWCHJ WKKW QUDV LHWZCHWS
VWHHO DQG IULFWLRQ SODWCHJ SODGW H RGL QJK ZLWRSWK

)LJ _____, QVWDOOLQJ 'LUHFW &OXWFK 3ODWHV
&RXUWHV\ RI)25' 02725 &2

,QVWDOO WKH GLUHFW FOXWFK VQDS ULQJ

)LJ _____, QVWDOOLQJ 'LUHFW &OXWFK 6QDS 5LQJ
&RXUWHV\ RI)25' 02725 &2

,QVWDOO WKH UROOHU EHDULQJ

)LJ _____, QVWDOOLQJ 5ROOHU %HDULQJ
&RXUWHV\ RI)25' 02725 &2

,17(50(',\$7(&/87&+ \$66(0%/<

0DWHULDO

0\$7(5,\$/ 63(&,),&\$7,21

,WHP	6SHFLILFDWLRQ
0(5&21Š 63 \$XWRPDWLF 7UDQVPLVLRQ)OXLC(5&21Š66\$	

'LVDVVHPEO\

)LJ (ISORGHG 9LHZ 2I ,QWHUPH&L&W&XWFK \$VVHPE
&RXUWHV\ RI)25' 02725 &2

5HPRYH WKH EHDULQJ UDFPDJHOHDQ DQG LQVSHFW IRU G
z ,I GDPDJH LV LQGLFDWHG DVHPELQZMLHUPHGLDWHKIEOK

)LJ _____ 5HPRYLQJ %HDULQJ 5DFH
&RXUWHV\ RI)25' 02725 &2

5HPRYH WKH LQWHUPHGLDWH FOXWFK SODWH VQDS UI

)LJ 5HPRYLQJ ,QWHUPHGLDWH &OXWFK 3ODWH 6QDS 5
&RXUWHV\ RI)25' 02725 &2

127(,QVSHFW WKH LQWHUPHGLDWH RFDUW WFK FWLXPQ FSK
VWHHO SODWHV IRU GDPDJH 1R QHZ FRPSRQHQW
,I QHZ FRPSRQHQWV DUH UHTXLUHG WKHQ QHZ WQH
VXSSRUW DVVHPEO\ LV UHTXLUHG

)LJ 5HPRYLQJ ,QWHUPHGLDWH &OXWFK 3ODWHV
&RXUWHV\ RI)25' 02725 &2

5HPRYH WKH LQWHUPHGLDWH F W O R Q F K Q S S E F M W W K / W M W O H D C
GDPDJH ,I GDPDJH LV LQGLFDW H K D V Q / H Z P E Q W Z I L O P H E I H D W H
z ,I QR GDPDJH LV LQGLFDW H F Q V E K I H U L H Q D W H U P H E C L D G V H F O

\$VVHPEO\

,QVWDOO WKH LQWHUPHGLDWH F W O R Q F K Q S S E F M W W K / W M W O H D C
EHWZHHQ IULFWLRQ DQG VWKHHS S I O D W X H V S O D W H Q G L Q J Z I

)LJ _____,QVWDOOLQJ ,QWHUPHGLDWH &OXWFK 3ODWHV
&RXUWHV\ RI)25' 02725 &2

,QVWDOO WKH LQWHUPHGLDWH FOXWFK SODWH VQDS I

)LJ _____, QVWDOOLQJ , QWHUPHIGL DWH & OXWFK 3ODWH 6QD
&RXUWHV\ RI)25' 02725 &2

, QVWDOO WKH EHDULQJ UDFH

)LJ _____, QVWDOOLQJ %HDULQJ 5DFH
&RXUWHV\ RI)25' 02725 &2

/2: 5(9(56(&/87&+ \$66(0%/<

0DWHULDO

0\$7(5,\$/ 63(&,), &\$7,21

,WHP	6SHFLILFDWLRQ
0(5&21\$ 63 \$XWRPDWLF 7UDQVPLVLRQ)OXLC(5&21\$66\$	

'LVDVVHPEO\

)LJ _____ (ISORGHG 9LHZ 2I /RZ 5HMHU & H & O K WFK \$VVHPE
&RXUWHV\ RI)25' 02725 &2

127(/RZ UHYHUVH FOXWFK SODWHH G XWHHQU QDWWH D P E H G S L O

5HPRYH WKH UROOHU EHDWIEQ JFRIQ WHKH VXS SHRUPWH G & O MDHQF
z ,I GDPDJH LV LQGLFDWHG B QWHZUL QXS SURFUHG IDW H PFCOX

)LJ 5HPRYLQJ 5ROOHU %HDULQJ
&RXUWHV\ RI)25' 02725 &2

127(,QVSHFW WKH ORZ UHYHUVB ~~SOXWFK~~ ~~SODGWHWHH~~
GDPDJH 1R QHZ FRPSRQHQWV DUH, ~~LQWZ~~ DOOHG
FRPSRQHQWV DUH UHTXLUHG D QHZVWUDQVLPVHG

,QVSHFW WKH LQWHUPHGLDWFWER ~~SOXWFK~~ ~~SODGWHWHH~~ ,VGHROJ
WUDQVPLVLRQ DVVHPEO\ ZLOO EH UHTXLUHG

z ,I QR GDPDJH LV LQGLFDWHDG ~~WKH~~ ~~ORZ~~ ~~WHPH~~ ~~QJH~~ FOXV

3803 \$66(0%/<

6SHFLDO 7RRO V

3803 \$66(0%/< 63(&,\$/ 722/

--	--

,QVWDOOHU)OXLG 3XPS 6H

0DWHULDO

0\$7(5,\$/ 63(&,),&\$7,21

,WHP	6SHFLILFDWLRQ
0(5&21Š 63 \$XWRPDWLF 7UDQVPLVLRQ)OXLG(5&21Š683	

'LVDVVHPEO\

5HPRYH WKH IURQW SXPS ZDVKHU

)LJ _____ 5HPRYLQJ)URQW 3XPS :DVKHU
&RXUWHV\ RI)25' 02725 &2

5HPRYH DQG GLVFDUG WKH IURQW SXPS 2 ULQJ VHDO

)LJ _____ 5HPRYLQJ)URQW 3XPS 2
&RXUWHV\ RI)25' 02725 &2

5HPRYH DQG GLVFDUG WKH IURQW SXPS VHDOV

)LJ _____ 5HPRYLQJ)URQW 3XPS 6HDOV
&RXUWHV\ RI)25' 02725 &2

5HPRYH WKH EROWV DQG ~~VHS DUB W W W H H S X P S E F Q~~

)LJ 6HSDUDWLQJ 3XPS &RQWURO %RG\)URP 3XPS %R
&RXUWHV\ RI)25' 02725 &2

,QVSHFW WKH SXPS ERG\ ~~DXVHH~~ VHDQGRFDGDHGDHGHZGX
UHTXLUHG

)LJ _____, QVSHFWLQJ 3XPS %RG\ 2XWHU 6HDO
&RXUWHV\ RI)25' 02725 &2

5HPRYH DQG LQVSHFW WKHHDOUHU DQG WKH RXWHU SXPS
z &OHDQ DOO SXPS SDUWV LQ VROYHQW
z 'U\ WKH SDUWV ZLWK FRPSUHVHVG DLU
z ,QVSHFW WKH SXPS JHDUV VDEHVDQGHDPDWLQJWXXUSDFSH
VFRULQJ
z ,QVWDOO D QHZ SXPS LI DQRURZRUKH SDUWV DUH GDPD

)LJ _____, QVWDOOLQJ 3XPS
&RXUWHV\ RI)25' 02725 &2

\$VVHPEO\

127(3ULRU WR LQVWDOODWLRQPSOLJHDMO\ZQXWUEEDW
DXWRPDWLF WUDQVPLVLRQ IOXLG

)LJ _____, QVWDOOLQJ 3XPS *HDUV
&RXUWHV\ RI)25' 02725 &2

, QVWDOO WKH SXPS JHDUR\ QZMLURK VERIG\ GB WWH PDEF\ QJ WKH
, QVWDOO D QHZ SXPS ERG\ RXWHU VHDO

)LJ _____, QVWDOOLQJ 3XPS %RG\ 2XWHU 6HDO
&RXUWHV\ RI)25' 02725 &2

\$VVHPEOH WKH SODWH DVVHPEO\ WR WKH SXPS ERG\ DVV
z 7LJKWHQ WR 1P OE IW

)LJ \$VVHPEOLQJ 3ODWH \$VVHPEO\ 7R 3XPS %RG\
&RXUWHV\ RI)25' 02725 &2

&\$87,21 0DNH VXUH WKH VHDO HQBQHDGHWRRHWKFWO
VHSDUDWHG

)LJ ,QVWDOOLQJ &RDVW &OXWFK 7HIORQ 6HDOV
&RXUWHV\ RI)25' 02725 &2

,QVWDOO WKH FRDVW FOXWFK 7HDOQSDVHDOO00VNDOW
JURRYHV DQG WKH VHDO HQSDUDWH RULHQWHG GHJUHH
,QVWDOO D QHZ SXPS RXWHLQGLVFDWHU IURQW SXPS

)LJ _____, QVWDOOLQJ 3XPS 2XWHU L'QDPHMDIU)URQW 3XPS
&RXUWHV\ RI)25' 02725 &2

127(/LJKWO\ OXEULFDWH WKH WDWXQW ZIDWKHSUHQBC
WR KROG WKHP LQ SODFH GXULQJ DVVHPEO\

)LJ _____, QVWDOOLQJ 3XPS 7KUXVW :DVKHU

&RXUWHV\ RI)25' 02725 &2

,QVWDOO WKH SXPS WKUXVW ZDVKHU

8VLQJ WKH VSHFLDO WR~~DO~~ LQVWDOO WKH IURQW SXPS V

)LJ _____,QVWDOOLQJ)URQW 3XPS 6HDO
&RXUWHV\ RI)25' 02725 &2