

INSTALLATION

TRANSMISSION - 4X4

Special Tool(s)

TRANSMISSION SPECIAL TOOL - 4x4

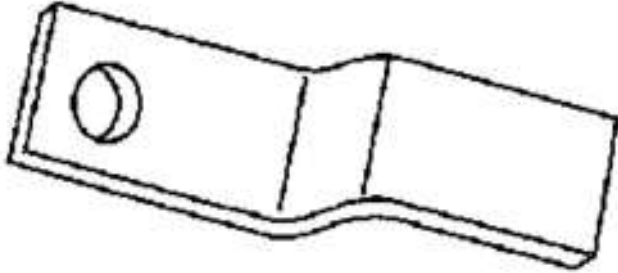

ST1636-A

Retainer, Torque Converter 307-346 (T97T-7902-A)

Worldwide Diagnostic System (WDS)
Vehicle Communication Module (VCM)
with appropriate adapters, or equivalent
diagnostic tool

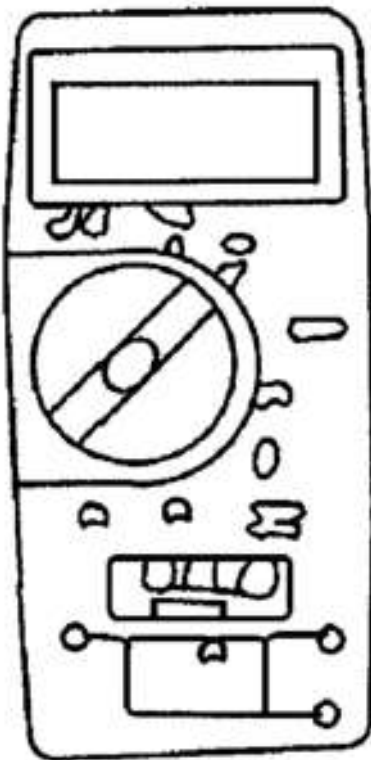

ST1137-A

Material

MATERIAL SPECIFICATION

Item	Specification
MERCON® SP Automatic Transmission Fluid XT-6-QSP	MERCON® SP

Installation

1. Install the special tool.

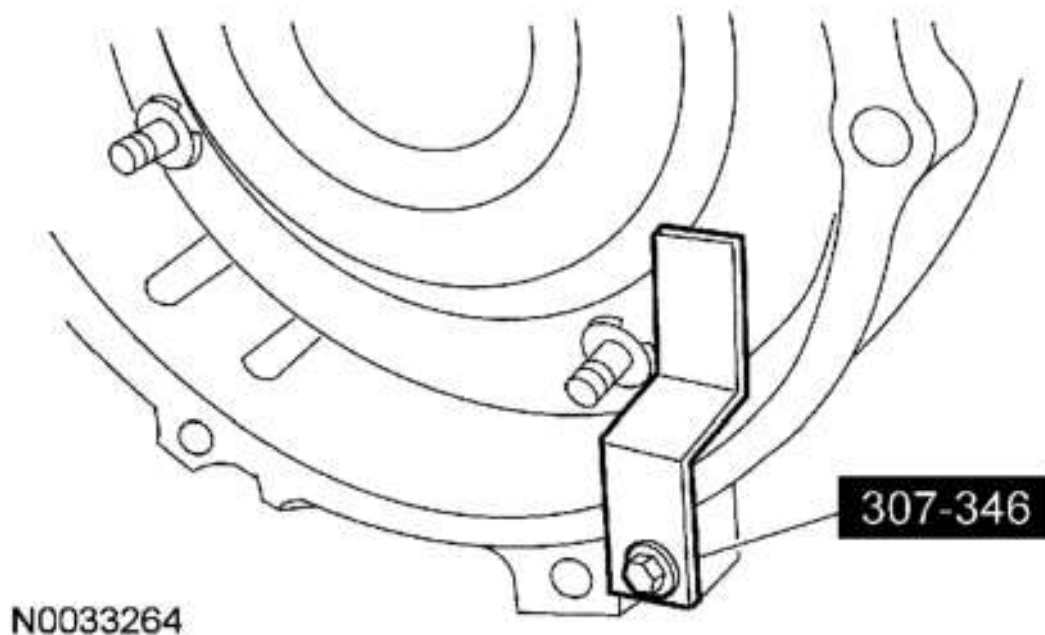

Fig. 314: Installing Special Tool
Courtesy of FORD MOTOR CO.

CAUTION: The converter housing is piloted into position by dowels in the rear of the engine block. The torque converter must rest squarely against the flexplate. This indicates that the converter pilot is not binding in the engine crankshaft.

2. Position and secure the transmission on the high-lift transmission jack. Raise and position the transmission into the vehicle.

NOTE: Make sure the torque converter is fully seated in the transmission before aligning the transmission to the engine.

3. With the transmission in a horizontal position move it toward the engine. Align the orange balancing marks between the torque converter studs and the flexplate bolt holes.

NOTE: Install the transmission bolts in their correct locations noted during removal.

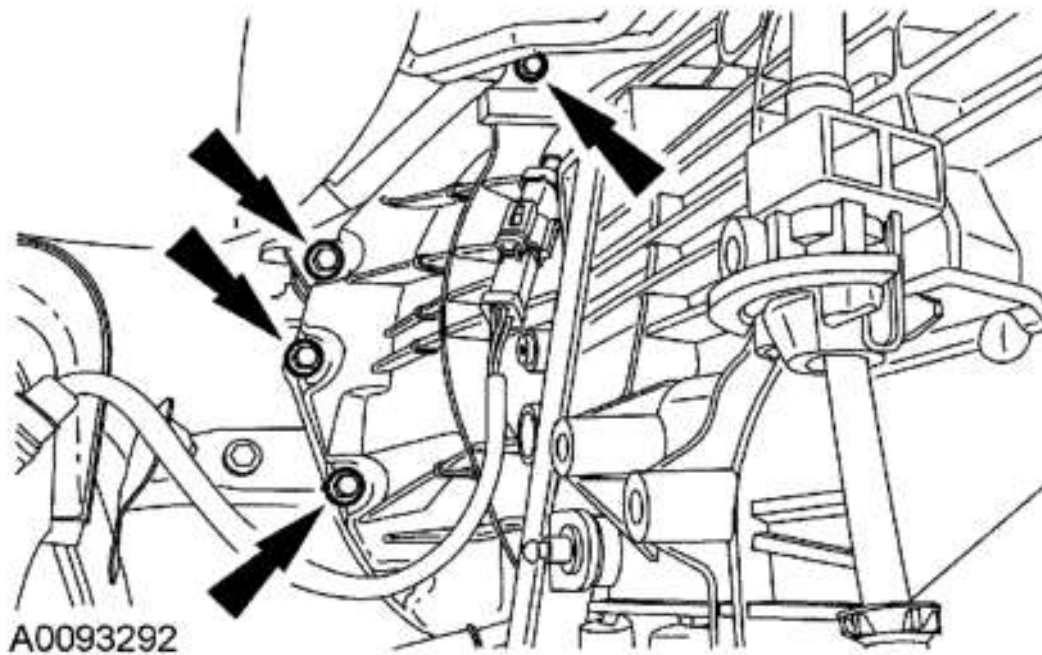
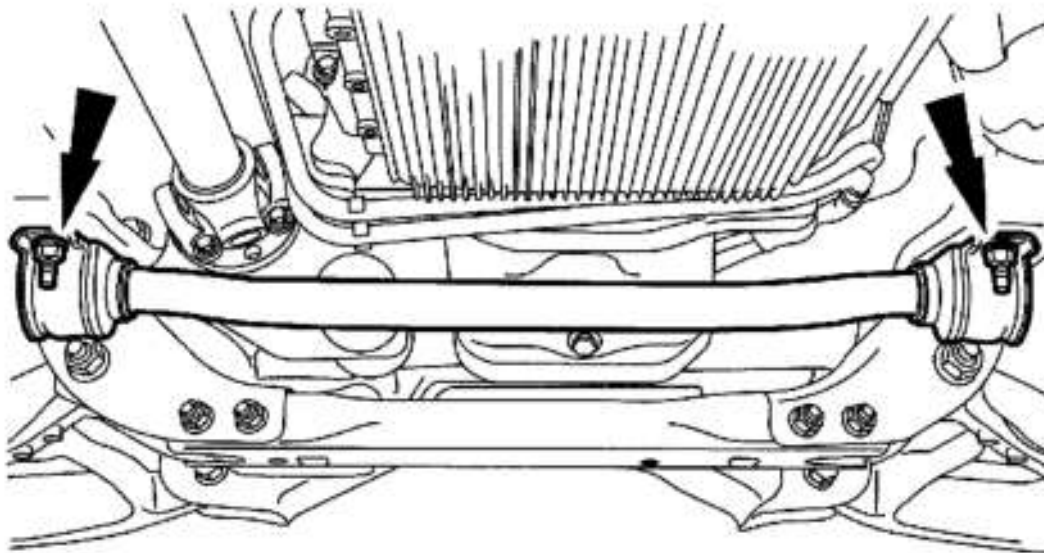

Fig. 315: Installing Transmission-To-Engine Bolts
Courtesy of FORD MOTOR CO.

4. Install the 7 transmission-to-engine bolts.
 - Tighten to 48 Nm (35 lb-ft).
5. Install the front sway bar U-brackets and the bolts.
 - Tighten to 102 Nm (75 lb-ft).



N0011369

Fig. 316: Installing Front Sway Bar U-Brackets And Bolts
Courtesy of FORD MOTOR CO.

6. Connect the wire harness retainer to the top of the transmission. Connect the main transmission electrical harness by pushing it in and twisting the outer shell to lock it in place.

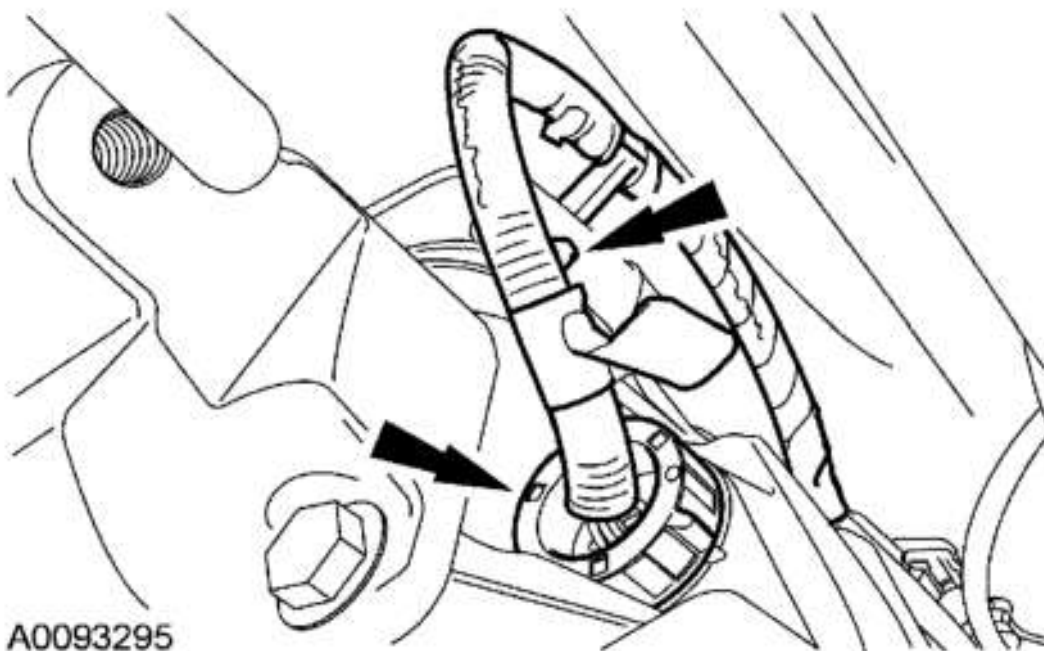

A0093295

Fig. 317: Connecting Wire Harness Retainer
Courtesy of FORD MOTOR CO.

7. Connect the wire harness to the top of the transmission.

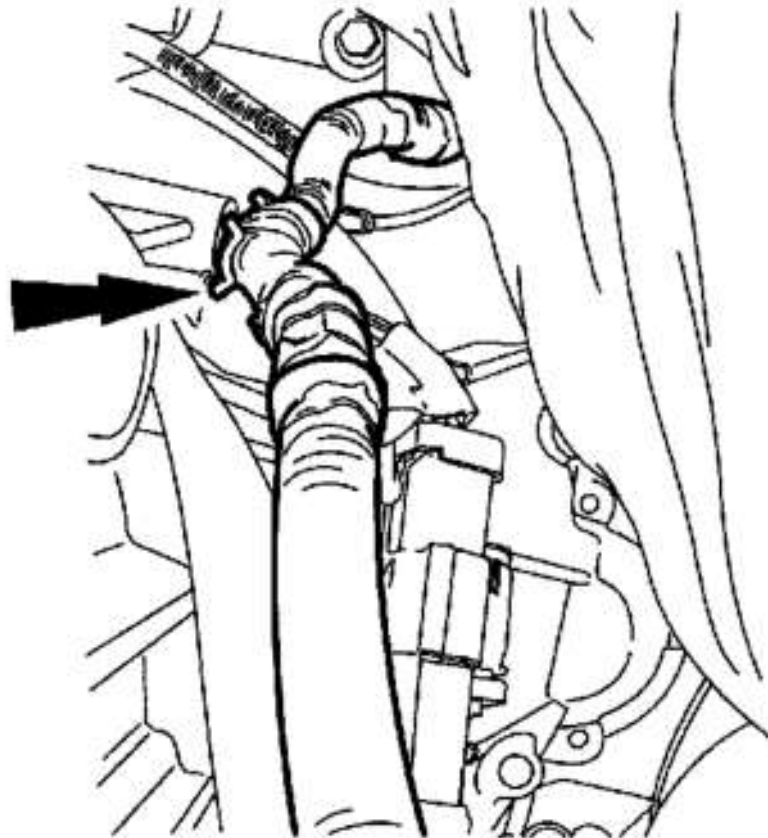

A0093294

Fig. 318: Connecting Wire Harness To Top Of Transmission
Courtesy of FORD MOTOR CO.

8. Connect the RH heated oxygen sensor (HO2S) electrical connector to the side of the transmission.

A0093293

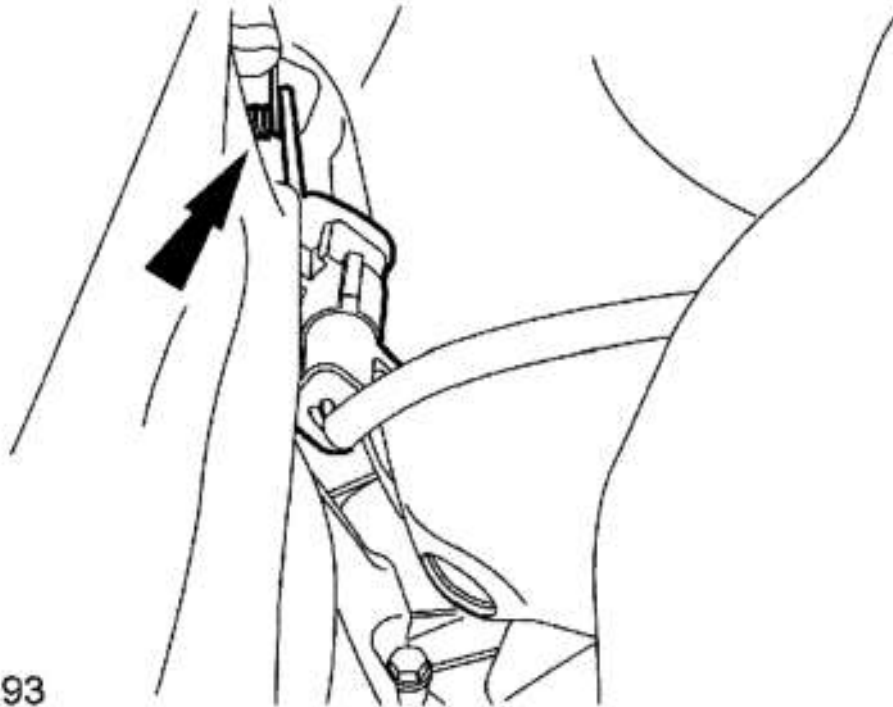

Fig. 319: Connecting RH Heated Oxygen Sensor
Courtesy of FORD MOTOR CO.

9. Connect the LH HO2S electrical connector to the side of the transmission.

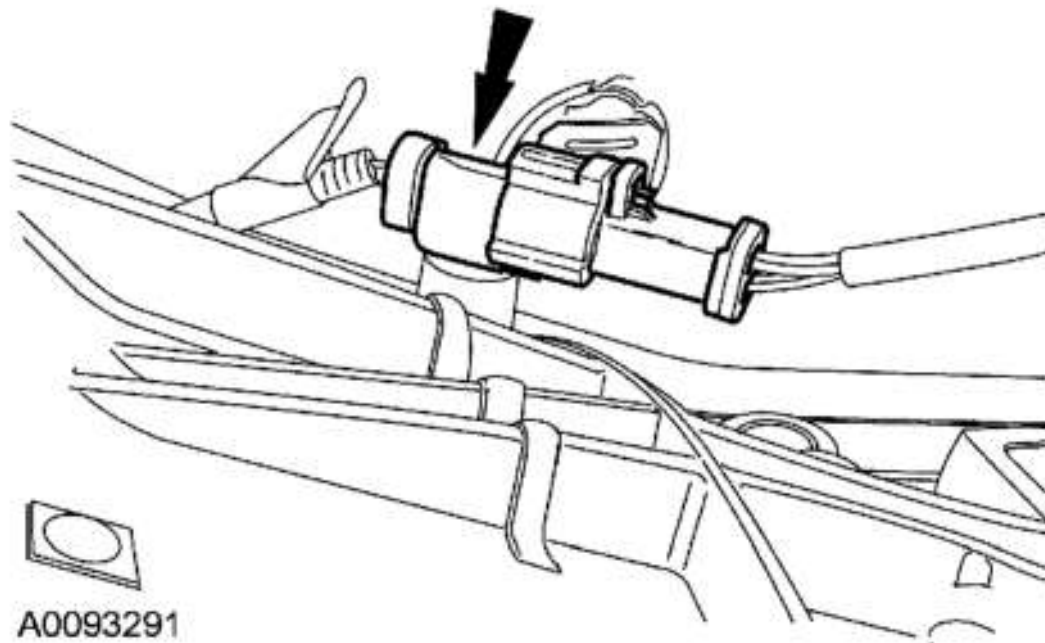

Fig. 320: Connecting LH HO2S Electrical Connector
Courtesy of FORD MOTOR CO.

10. Install the rear transmission mount. Install the LH bolt for the rear transmission support.
 - Tighten to 80 Nm (59 lb-ft).

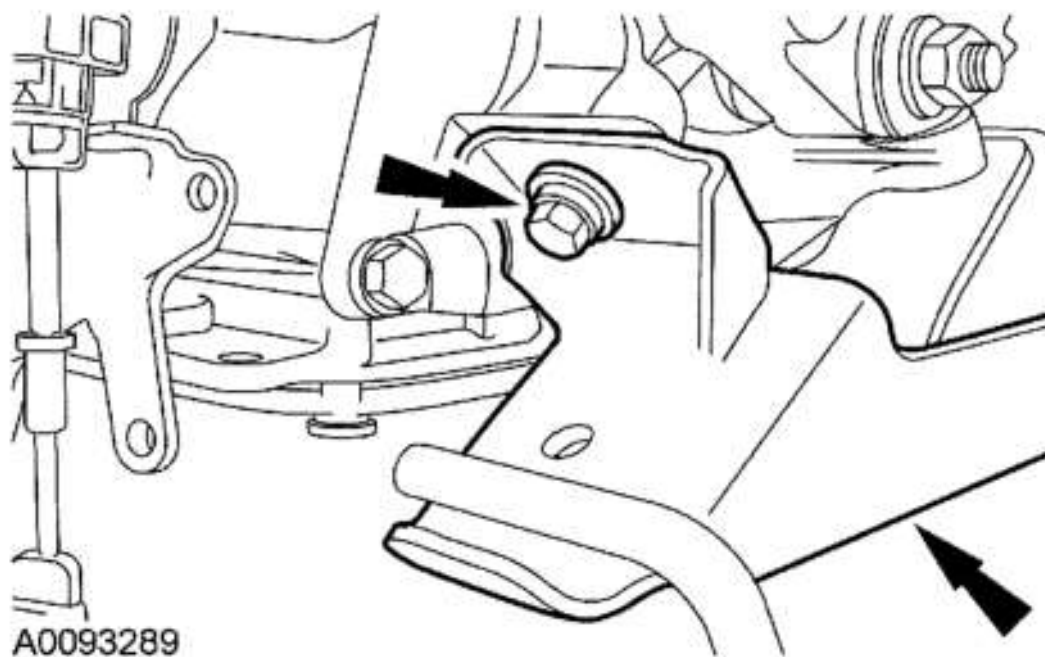

Fig. 321: Installing Rear Transmission Mount
Courtesy of FORD MOTOR CO.

11. Install the RH bolt for the rear transmission support.
 - Tighten to 80 Nm (59 lb-ft).

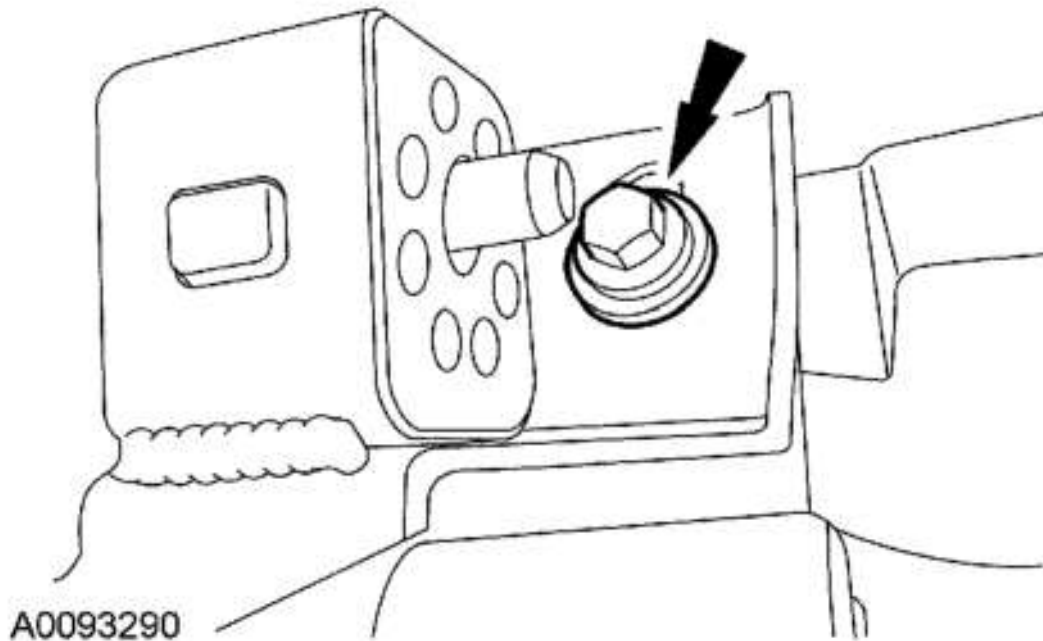

Fig. 322: Installing RH Bolt
Courtesy of FORD MOTOR CO.

12. Install the exhaust hanger.
 - Tighten to 40 Nm (30 lb-ft).

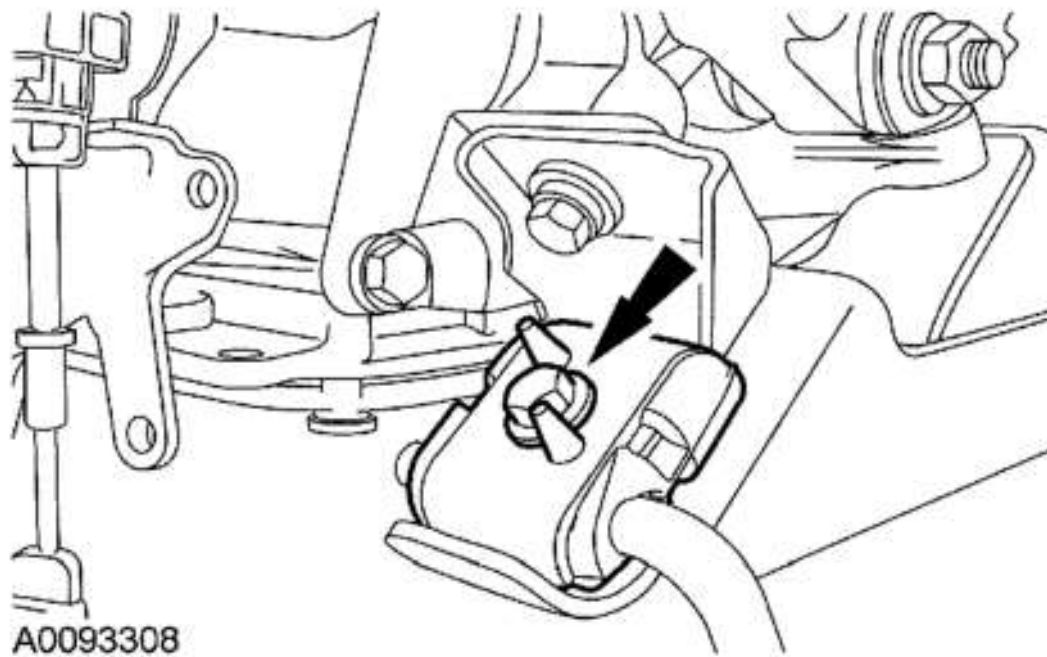

Fig. 323: Installing Exhaust Hanger
Courtesy of FORD MOTOR CO.

13. Position the rear crossmember in place and loosely install the transmission retaining nuts.

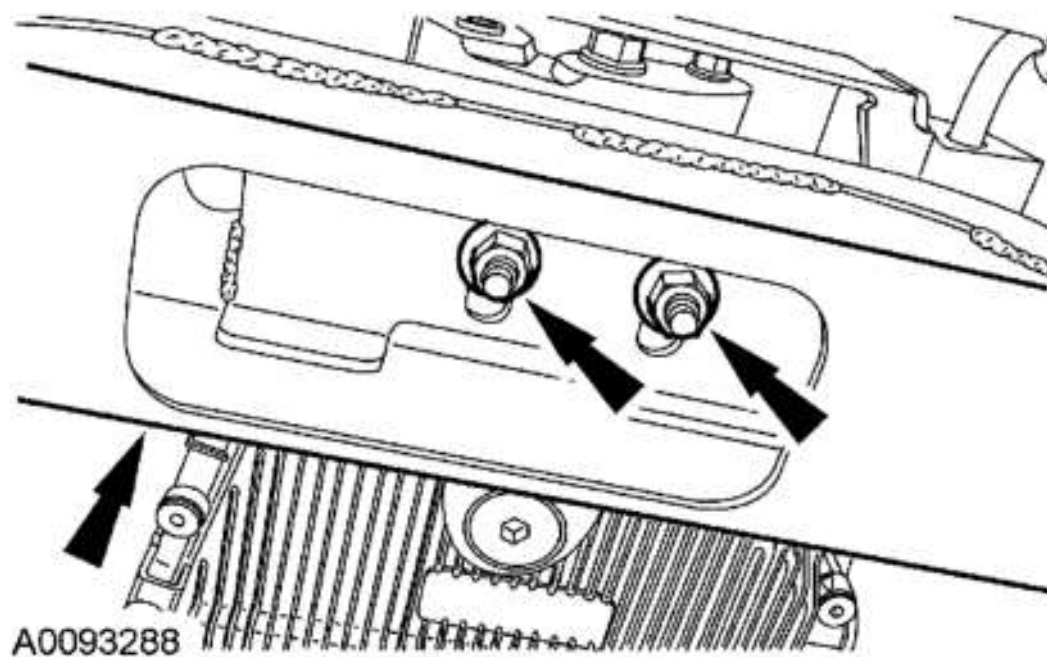

Fig. 324: Installing Transmission Retaining Nuts

Courtesy of FORD MOTOR CO.

14. Install the bolts for the rear crossmember.
 - Tighten to 90 Nm (66 lb-ft).

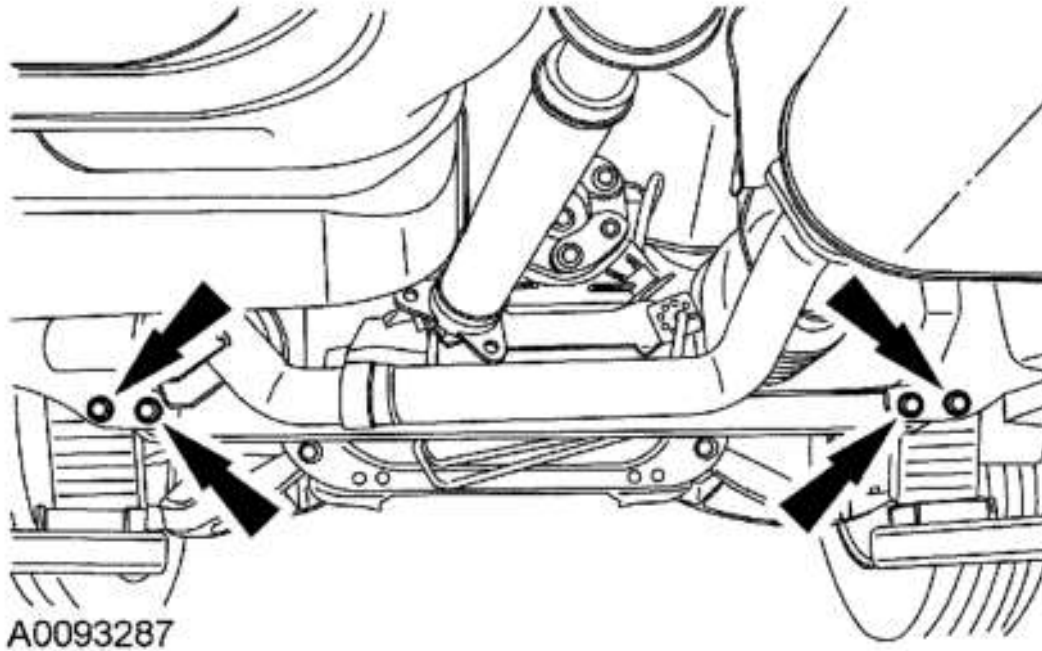

Fig. 325: Installing Rear Crossmember Bolts
Courtesy of FORD MOTOR CO.

15. Tighten the 2 rear transmission nuts.
 - Tighten to 103 Nm (76 lb-ft).

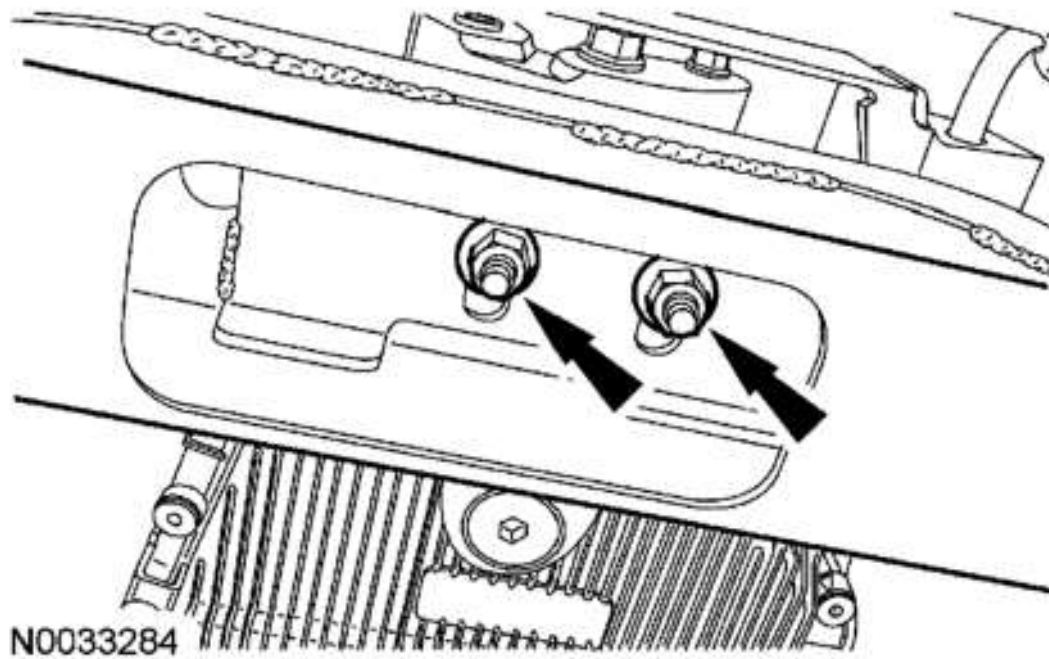

Fig. 326: Tightening Rear Transmission Nuts
Courtesy of FORD MOTOR CO.

16. Install the RH exhaust heat shield bolt.
 - Tighten to 15 Nm (11 lb-ft).

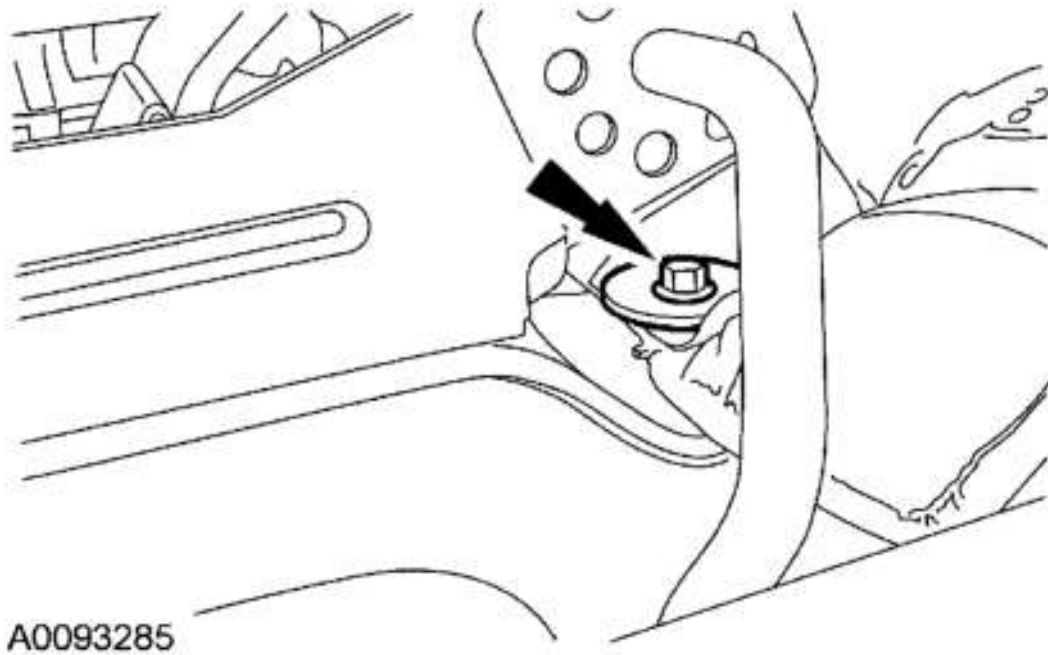

Fig. 327: Installing RH Exhaust Heat Shield Bolt
Courtesy of FORD MOTOR CO.

17. Install the LH exhaust heat shield bolt.
 - Tighten to 15 Nm (11 lb-ft).

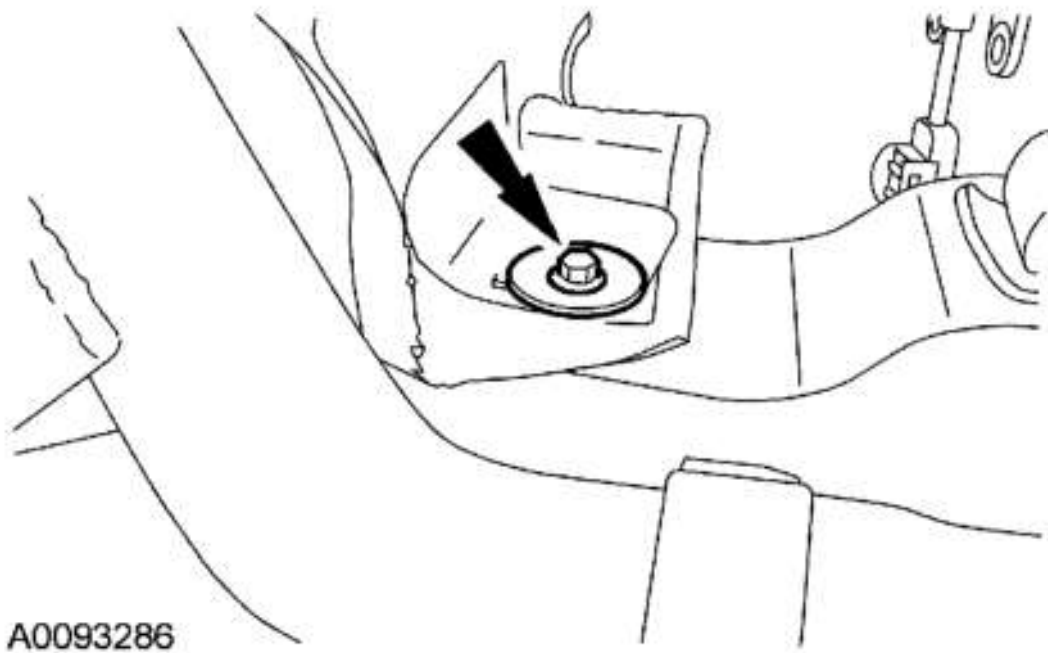

Fig. 328: Installing LH Exhaust Heat Shield Bolt
Courtesy of FORD MOTOR CO.

18. Connect the transmission fluid cooler tubes.

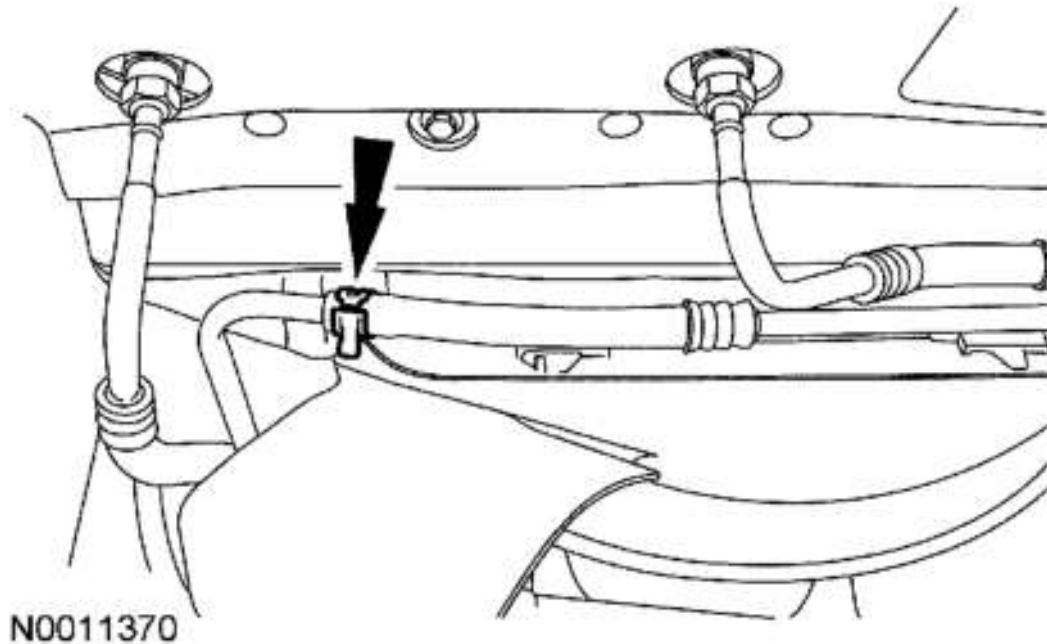

Fig. 329: Connecting Transmission Fluid Cooler Tubes
Courtesy of FORD MOTOR CO.

19. Install the transmission fluid cooler tube bracket and the nut.
 - Tighten to 27 Nm (20 lb-ft).

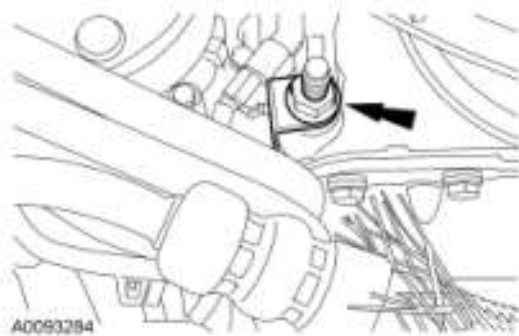

Fig. 330: Identifying Transmission Fluid Cooler Tube Bracket & Nut
Courtesy of FORD MOTOR CO.

20. Connect the engine oil level sensor electrical connector.

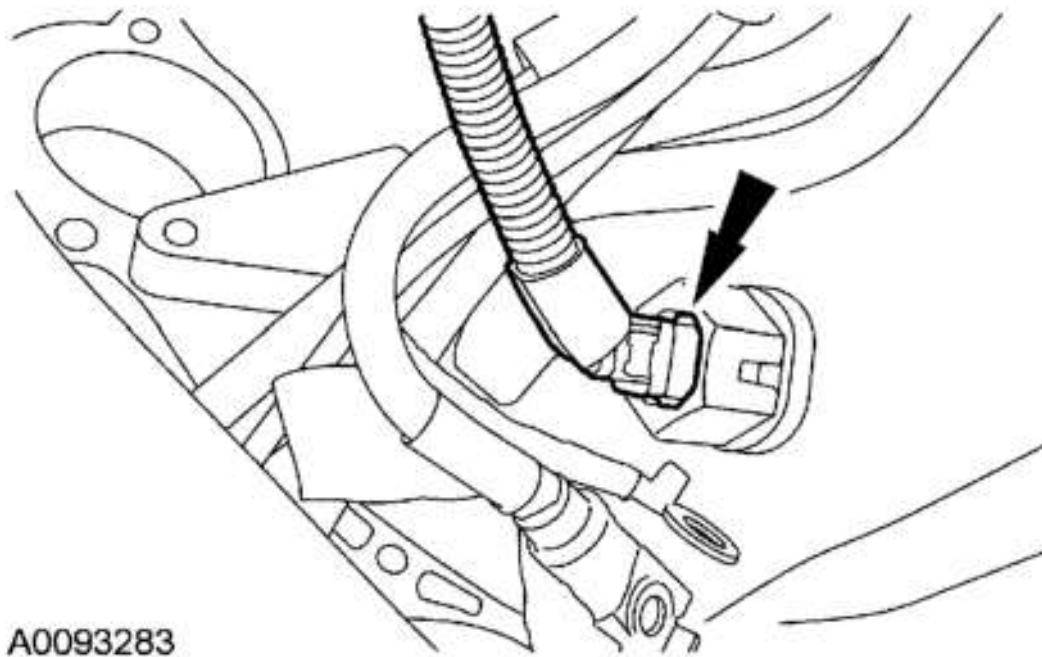

Fig. 331: Connecting Engine Oil Level Sensor Electrical Connector
Courtesy of FORD MOTOR CO.

21. Install the transmission fluid cooler tube retainer and the bolt.
 - Tighten to 48 Nm (35 lb-ft).

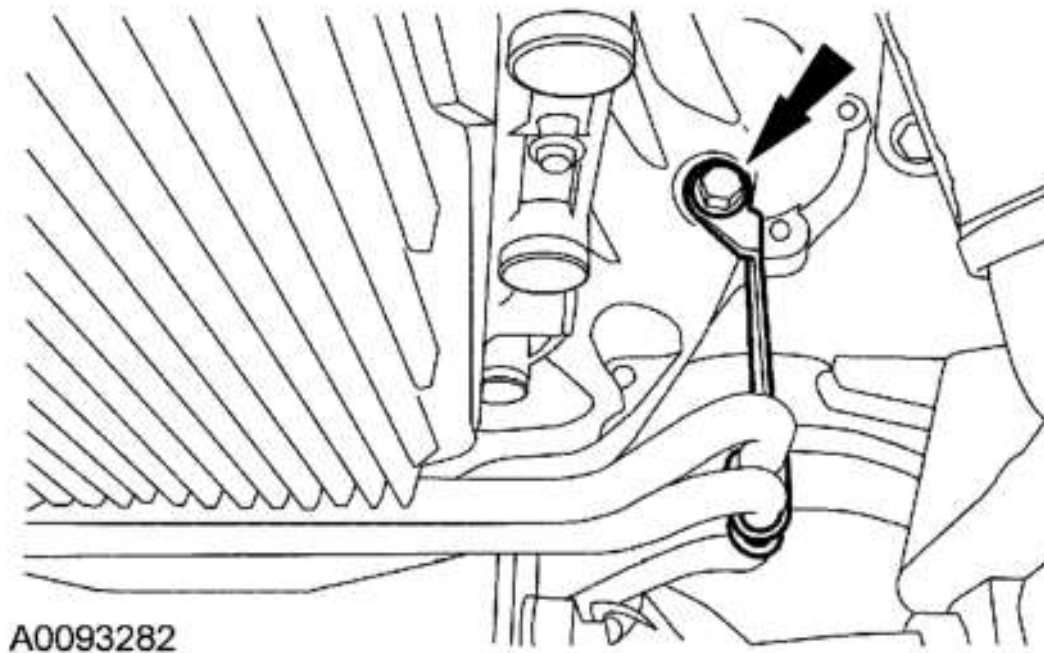
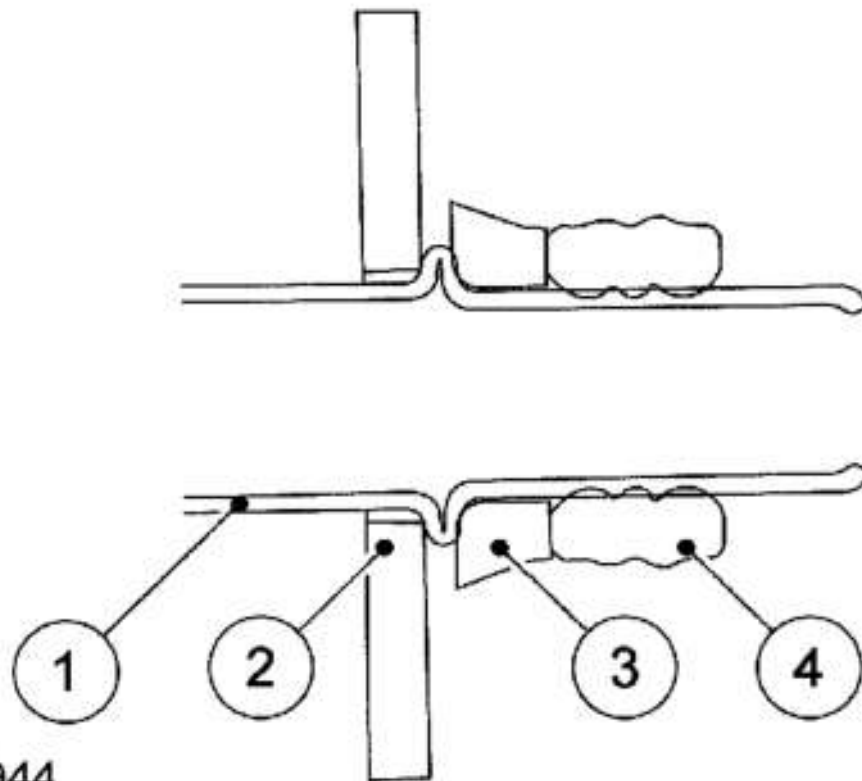

Fig. 332: Installing Transmission Fluid Cooler Tube Retainer
Courtesy of FORD MOTOR CO.

- NOTE:** Inspect the case to make sure that the old band seals and backer rings are not stuck in the case.
- NOTE:** Install new band seals and backer rings on the ends of the cooler tubes prior to installing.



N0013944

Fig. 333: Installing New Seals
Courtesy of FORD MOTOR CO.

22. Install new seals on the transmission fluid cooler tubes.
 1. Transmission fluid cooler tube.
 2. Retainer plate.
 3. Backer ring.
 4. Band seal.

NOTE: Inspect the case to make sure that the old band seals and backer rings are not stuck in the case.

NOTE: Install new band seals and backer rings on the ends of the cooler tubes prior to installing.

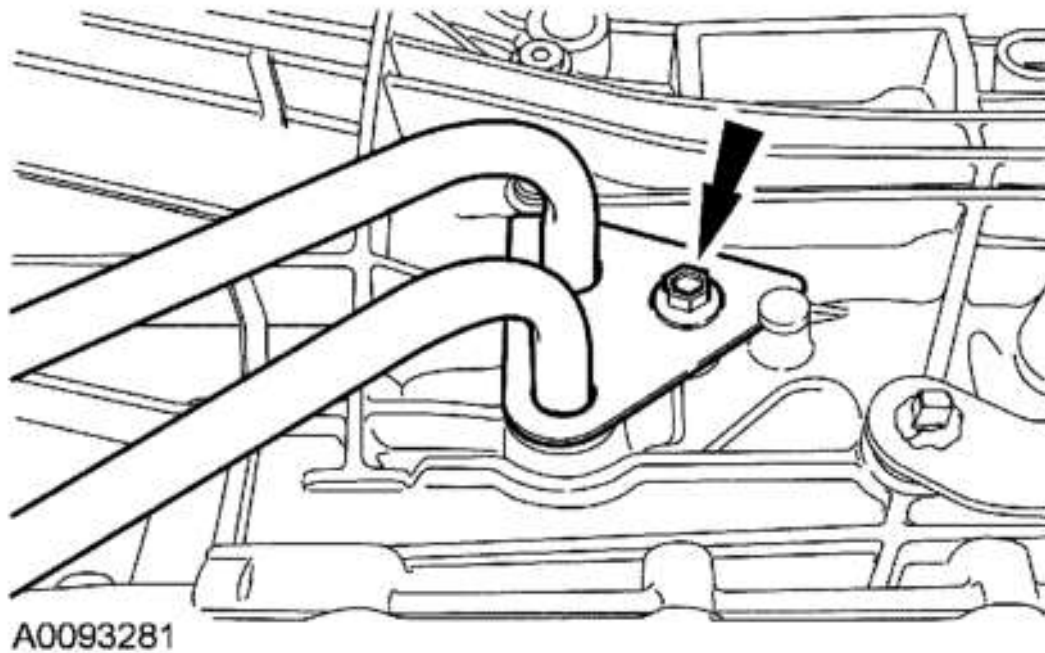

Fig. 334: Installing Transmission Cooler Tube Retainer Bolt
Courtesy of FORD MOTOR CO.

23. Position the fluid cooler tubes into the transmission, then install the bolt for the transmission cooler tube retainer.
 - Tighten to 23 Nm (17 lb-ft).
24. Install the starter motor and the 3 bolts.
 - Tighten to 26 Nm (19 lb-ft).

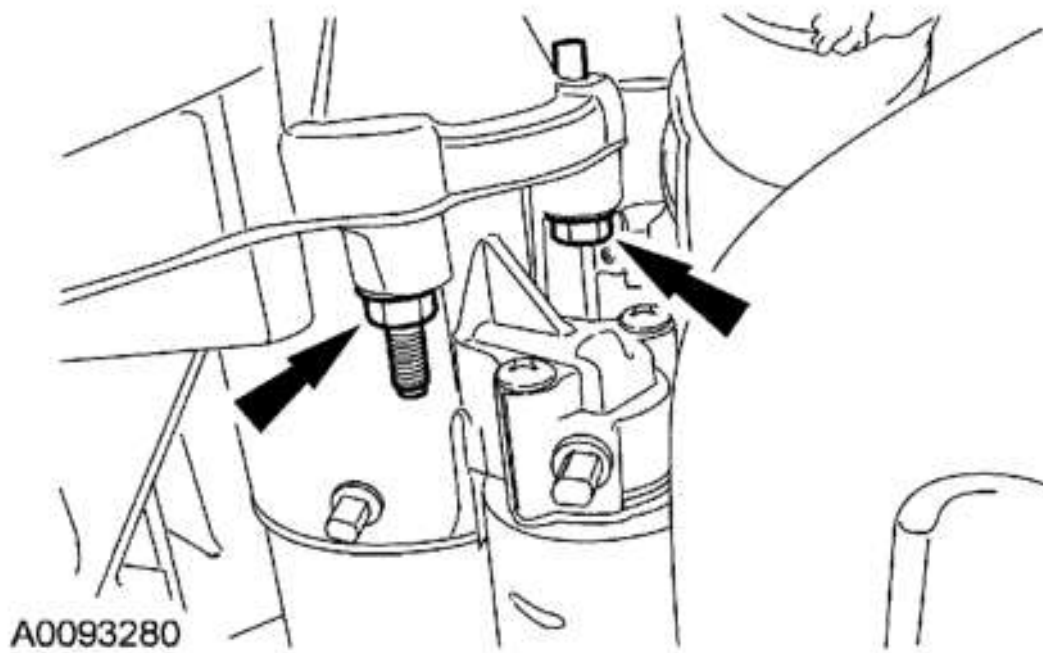

Fig. 335: Installing Starter Motor
Courtesy of FORD MOTOR CO.

25. Install the ground wire to the stud.
 - Tighten to 23 Nm (17 lb-ft).

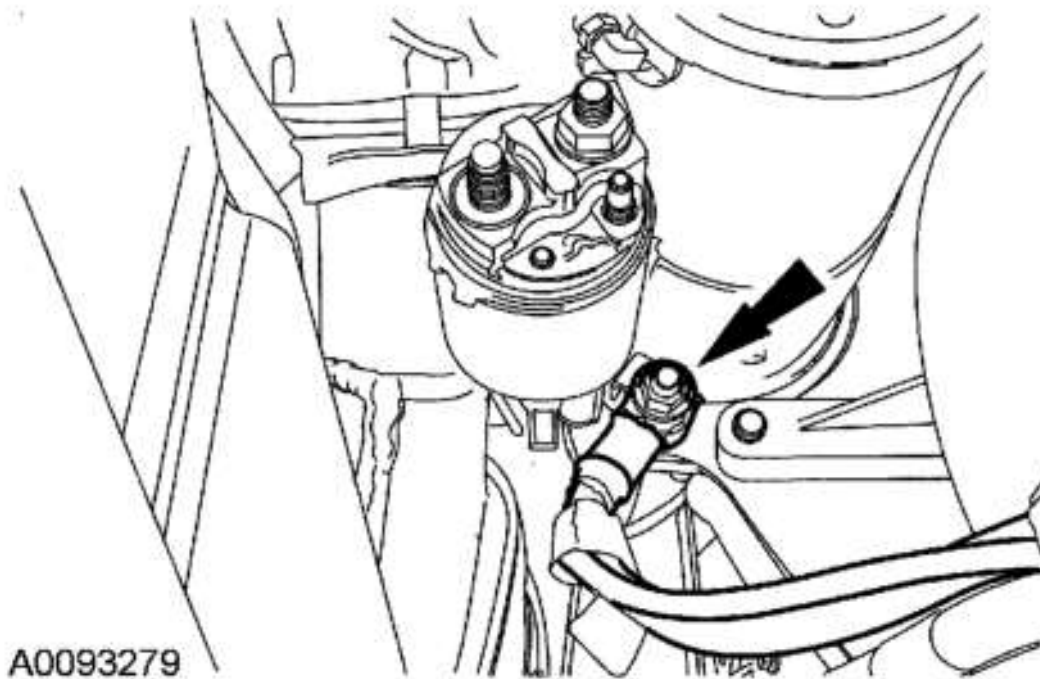

Fig. 336: Installing Ground Wire
Courtesy of FORD MOTOR CO.

26. Install the starter motor electrical connectors.
 1. Tighten to 12 Nm (9 lb-ft).
 2. Tighten to 6 Nm (53 lb-in).

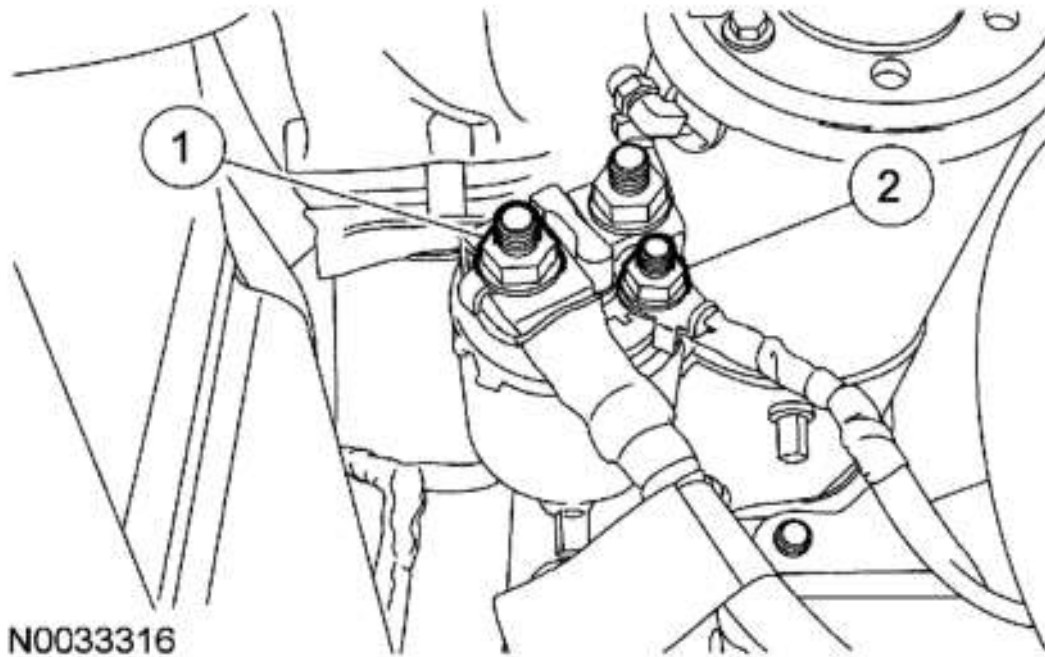

Fig. 337: Installing Starter Motor Electrical Connectors
Courtesy of FORD MOTOR CO.

27. Install the plastic starter motor electrical connector cap.

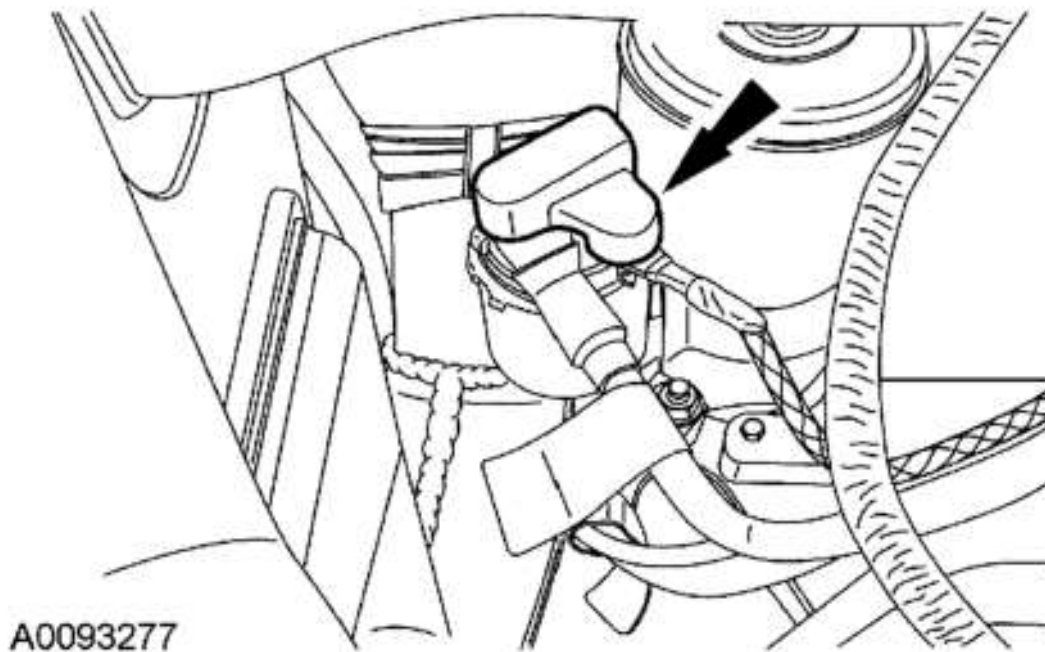

Fig. 338: Installing Plastic Starter Motor Electrical Connector Cap
Courtesy of FORD MOTOR CO.

28. Install 4 new torque converter nuts.
 - Rotate the crankshaft to access all the torque converter nuts.
 - Tighten to 35 Nm (26 lb-ft).

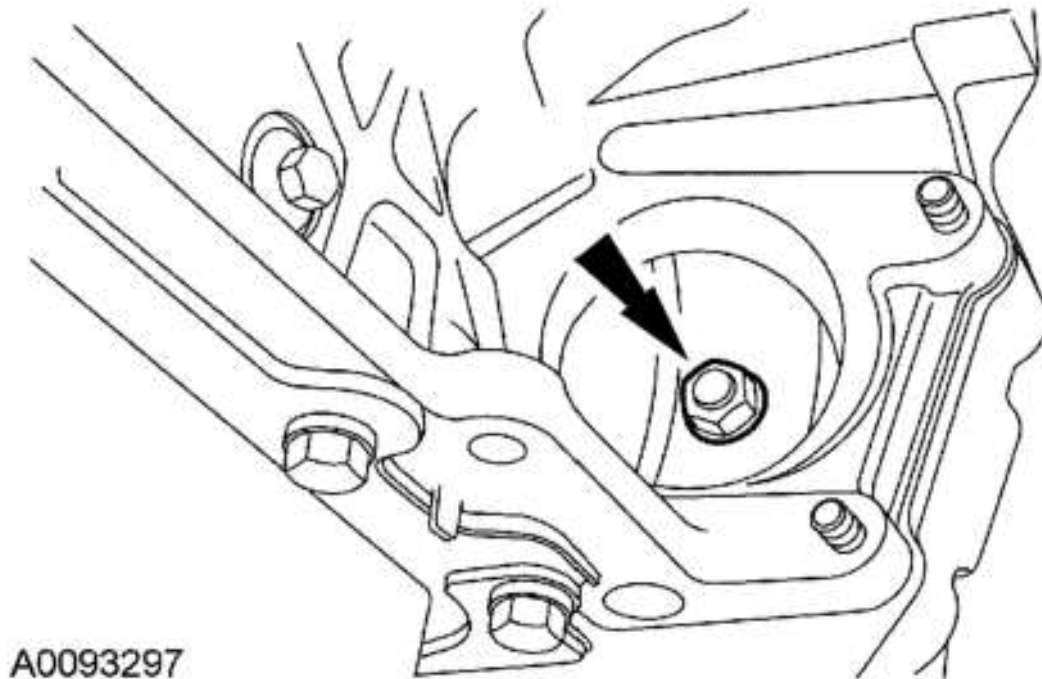

Fig. 339: Locating Bolt
Courtesy of FORD MOTOR CO.

29. Install the rubber access plug.

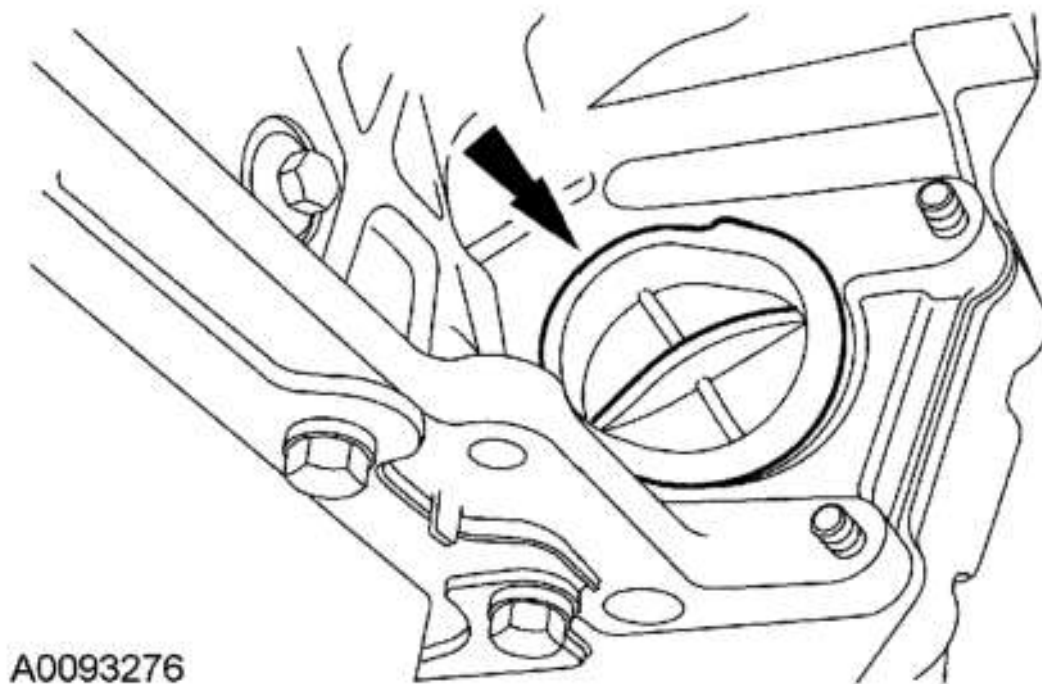
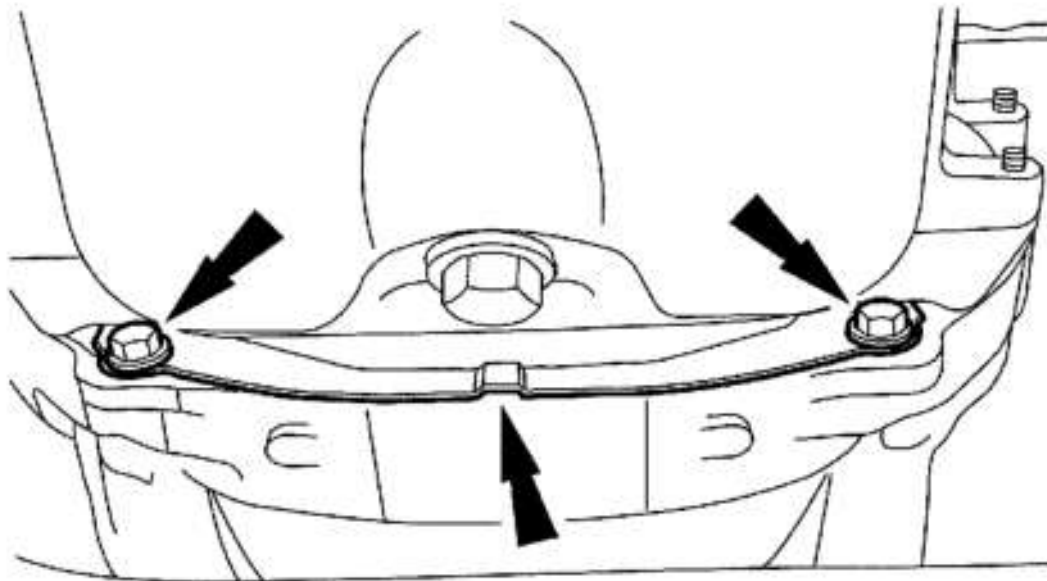

Fig. 340: Installing Rubber Access Plug
Courtesy of FORD MOTOR CO.

30. Install the flexplate inspection cover.
 - Tighten to 35 Nm (26 lb-ft).



A0093275

Fig. 341: Installing Flexplate Inspection Cover
Courtesy of FORD MOTOR CO.

31. Install the RH engine-to-transmission support bracket and the bolts.
 - Tighten to 48 Nm (35 lb-ft).

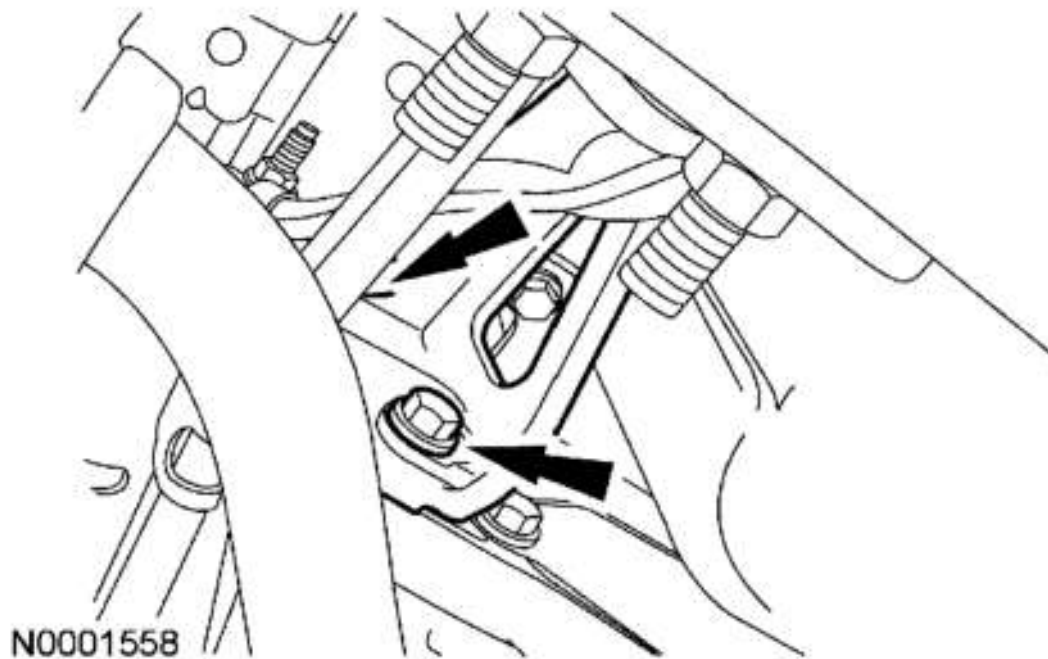

Fig. 342: Installing RH Engine-To-Transmission Support Bracket
Courtesy of FORD MOTOR CO.

32. Install the LH engine-to-transmission support bracket and the bolts.
 - Tighten to 48 Nm (35 lb-ft).

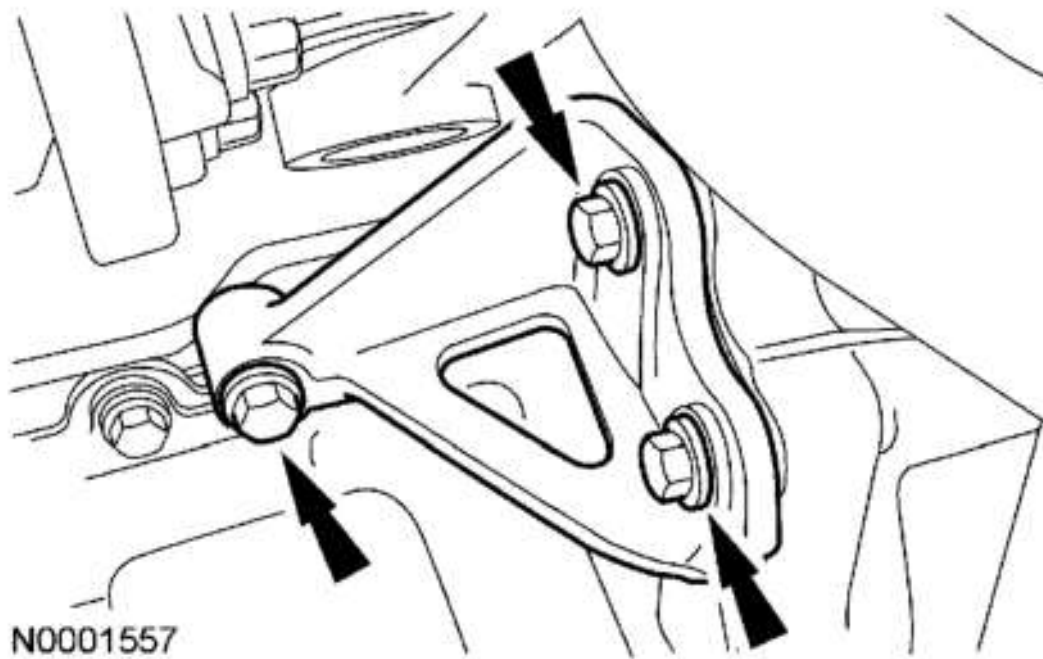

Fig. 343: Installing LH Engine-To-Transmission Support Bracket
Courtesy of FORD MOTOR CO.

33. Install the shift cable bracket bolts and connect the shift cable end.
 - Tighten to 48 Nm (35 lb-ft).

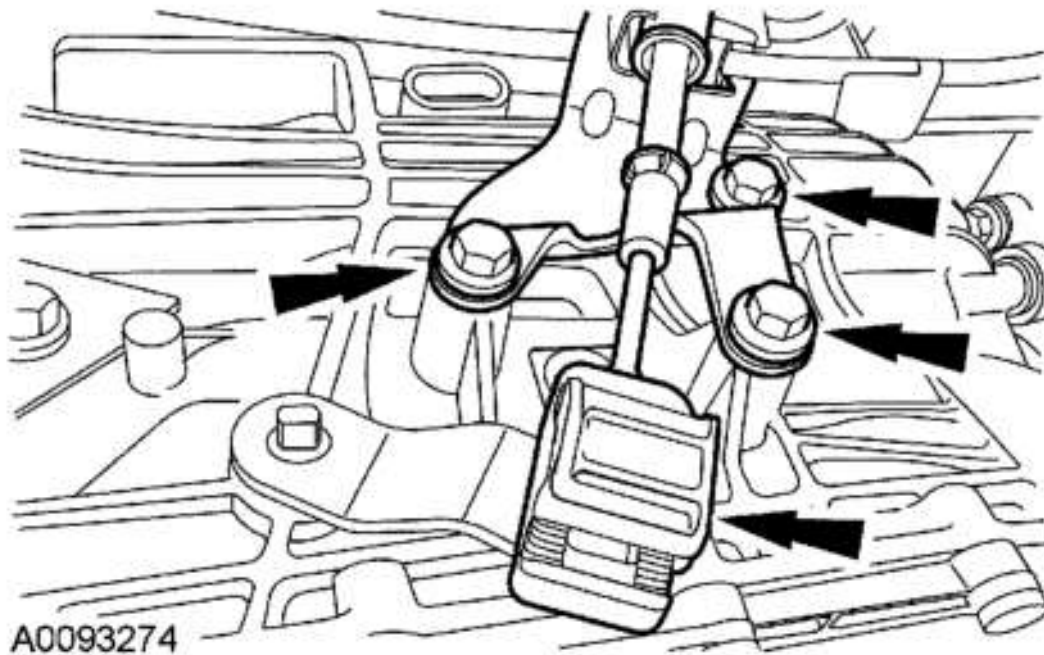

Fig. 344: Locating Shift Cable Bracket Bolts
Courtesy of FORD MOTOR CO.

34. Install the transfer case. For additional information, refer to **TRANSFER CASE - AUTOMATIC SHIFT** .

NOTE: **4x2 shown, 4x4 similar.**

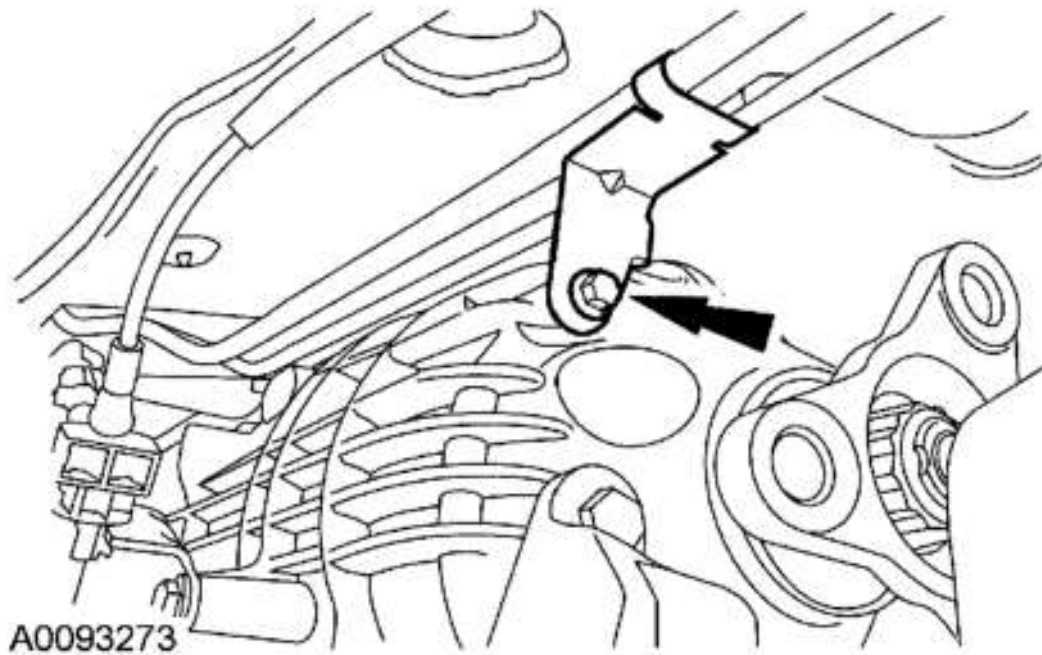

Fig. 345: Installing Fuel Line Bracket & Bolt
Courtesy of FORD MOTOR CO.

35. Install the fuel line bracket and the bolt.
 - Tighten to 25 Nm (18 lb-ft).
36. Connect the battery ground cable.

CAUTION: The fluid fill plug located on the side of the transmission is near the exhaust system. The exhaust will be extremely hot during this procedure. Use care when working near the exhaust and the heat shields.

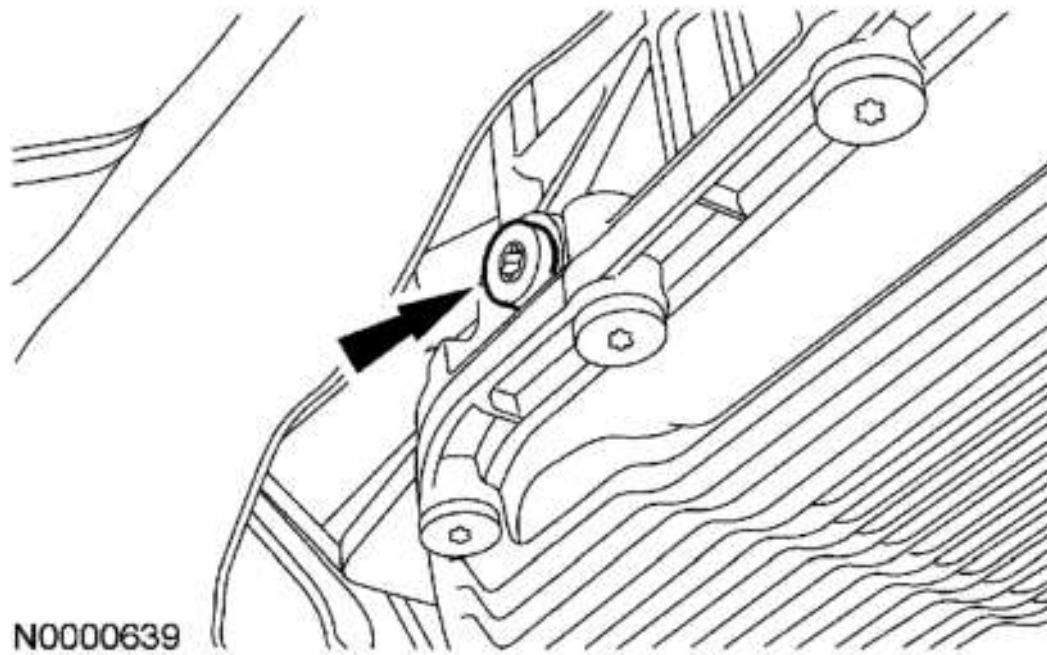

Fig. 346: Locating Fill Plug
Courtesy of FORD MOTOR CO.

37. Remove the fluid fill plug.
 - The fill plug is located on the RH rear side of the case near the transmission electrical connector.

CAUTION: The use of any other transmission fluid than specified, can result in the transmission failing to operate correctly or transmission failure.

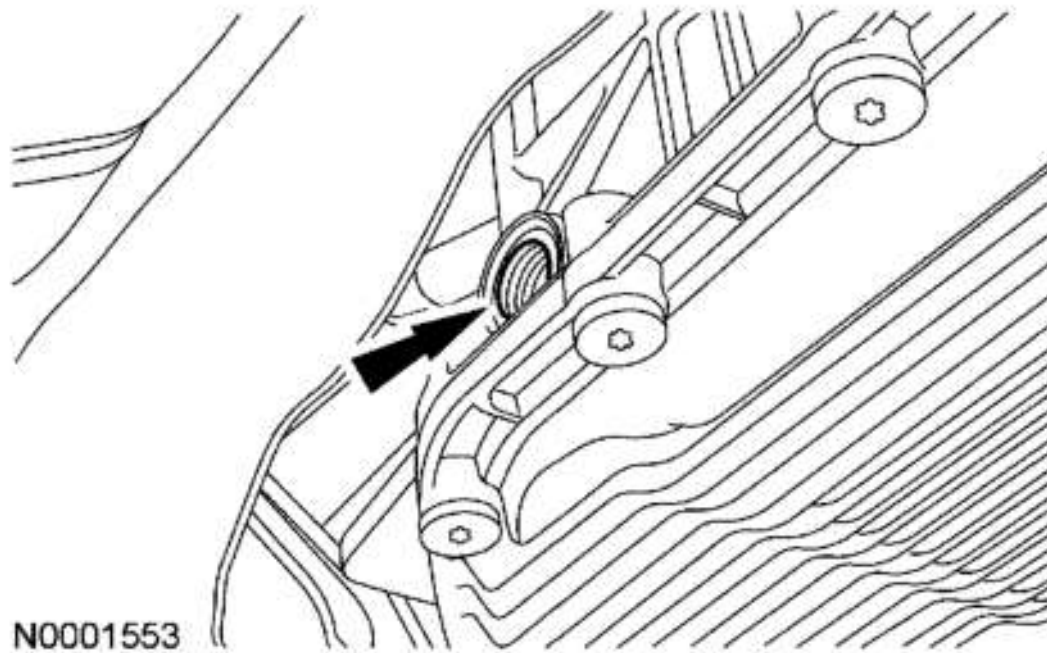

Fig. 347: Locating Fluid Fill Plug
Courtesy of FORD MOTOR CO.

38. Fill the transmission.
 - Add 4.7 liters (5 quarts) of clean automatic transmission fluid to the transmission through the fluid fill hole. Stop when the fluid runs out of the bottom of the hole.
39. Install the fluid fill plug.
 - Tighten to 35 Nm (26 lb-ft).

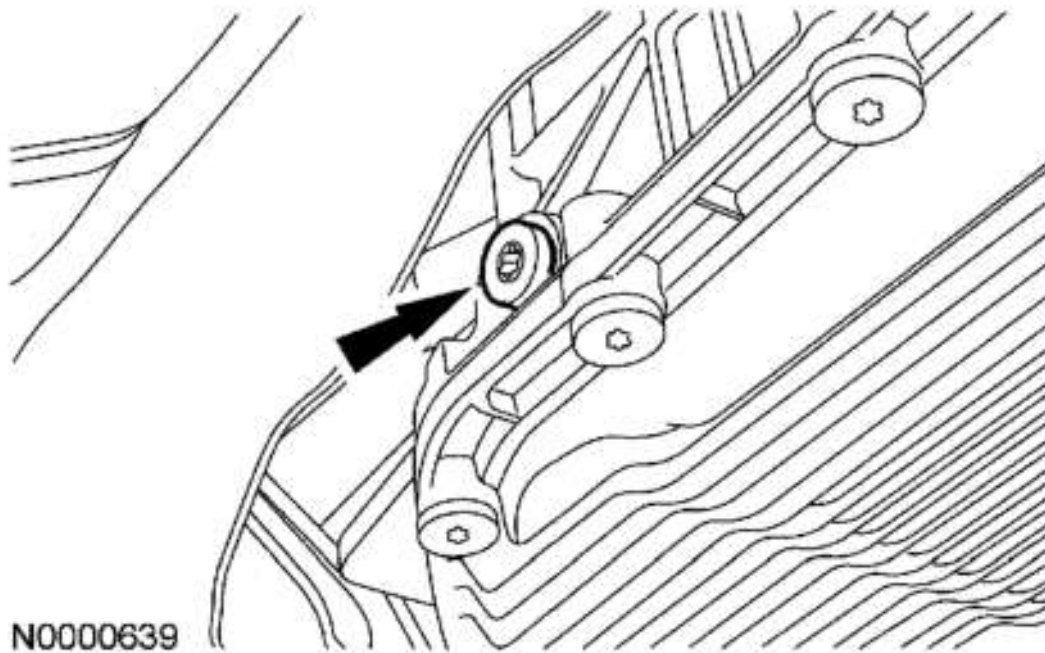

Fig. 348: Installing Fill Plug
Courtesy of FORD MOTOR CO.

40. Verify that the shift cable is correctly adjusted. For additional information, refer to **AUTOMATIC TRANSAXLE/TRANSMISSION EXTERNAL CONTROLS** .
41. Reflash the transmission control module (TCM) to the latest level of software.
42. Start the engine. Move the transmission range selector lever through all the gear ranges, checking for engagements.
43. With the engine idling (600-750 rpm) in PARK and the transmission temperature at 30°C-50°C (86° F-122°F), check and adjust the transmission fluid level.

CAUTION: The fluid fill plug located on the side of the transmission is near the exhaust system. The exhaust will be extremely hot during this procedure. Use care when working near the exhaust and the heat shields.

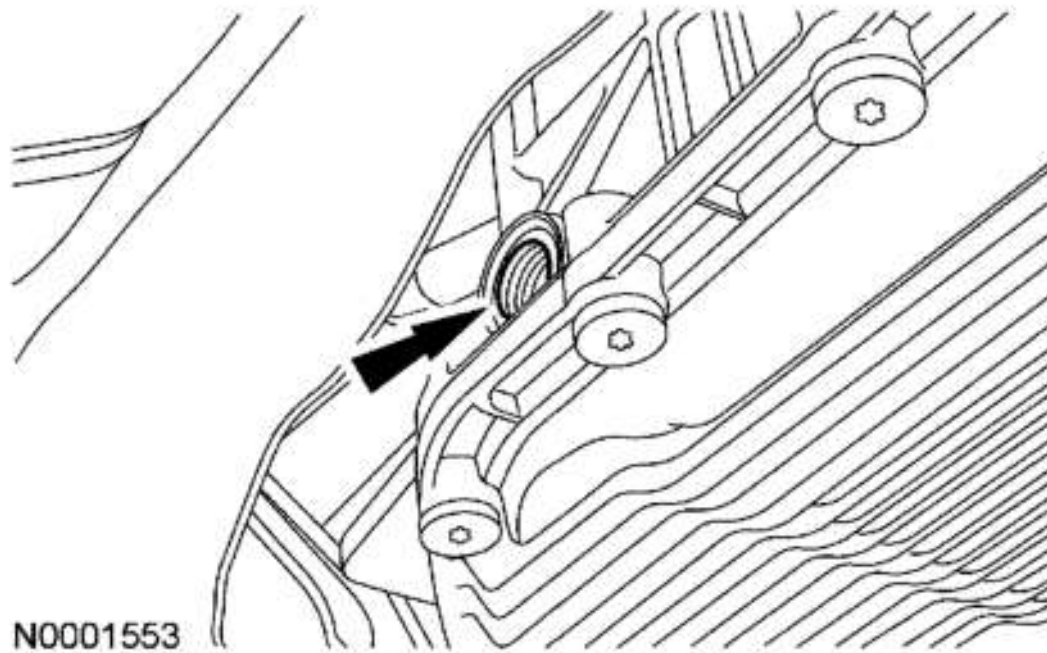

Fig. 349: Locating Fluid Fill Plug
Courtesy of FORD MOTOR CO.

44. With the engine still running in PARK, check the fluid level. If more fluid is needed, remove the fluid fill plug on the side of the case and fill with clean automatic transmission fluid until the fluid runs out of the bottom of the hole.
45. Install the fluid fill plug.
 - Tighten to 35 Nm (26 lb-ft).

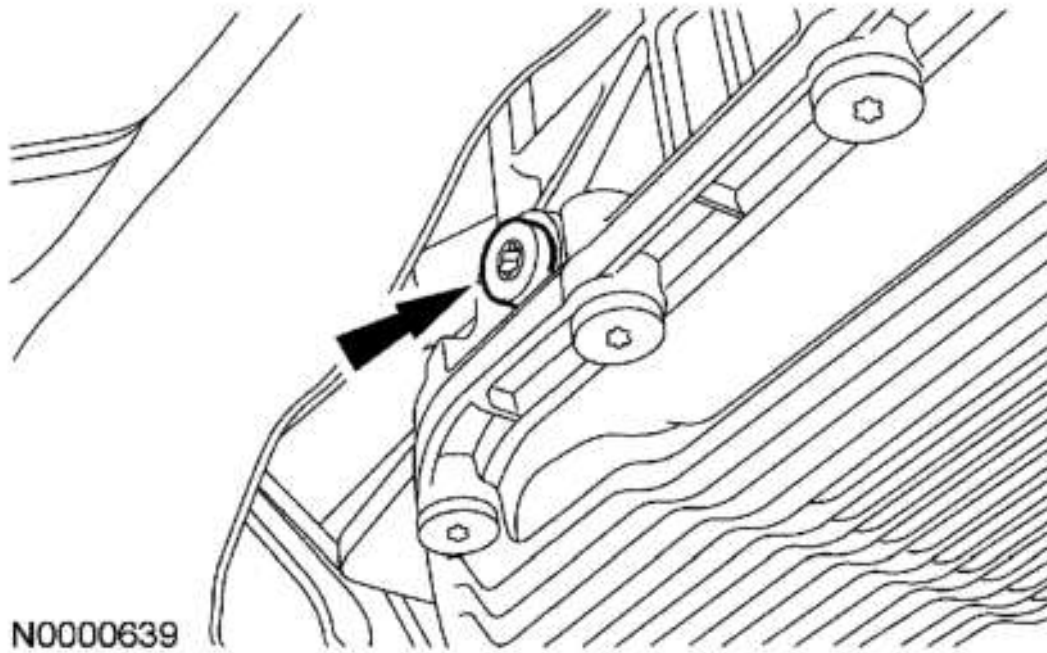
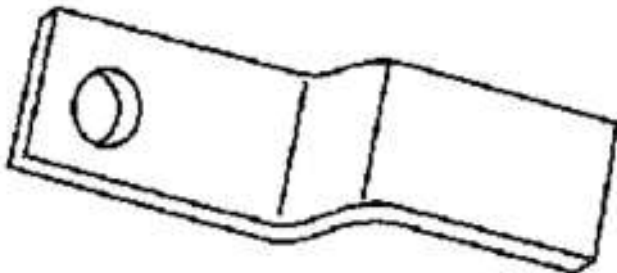

Fig. 350: Installing Fill Plug
 Courtesy of FORD MOTOR CO.

TRANSMISSION - 4X2

Special Tool(s)

TRANSMISSION SPECIAL TOOL - 4x2



ST1636-A

Retainer, Torque Converter 307-346 (T97T-7902-A)

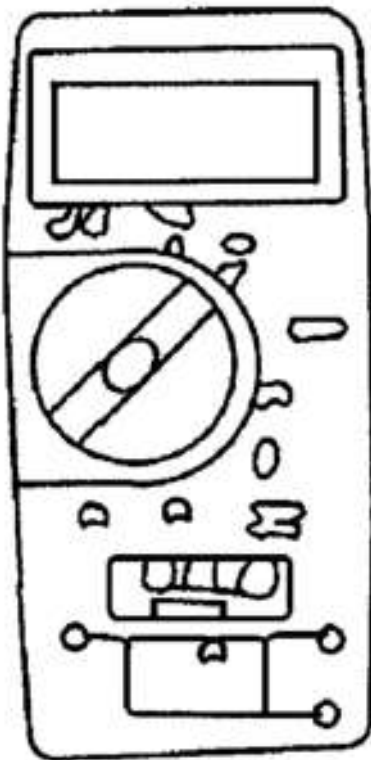

ST1137-A

Worldwide Diagnostic System (WDS)
Vehicle Communication Module (VCM)
with appropriate adapters, or equivalent
diagnostic tool

Material

MATERIAL SPECIFICATION

Item	Specification
MERCON® SP Automatic Transmission Fluid XT-6-QSP	MERCON® SP

Installation

1. Install the special tool.

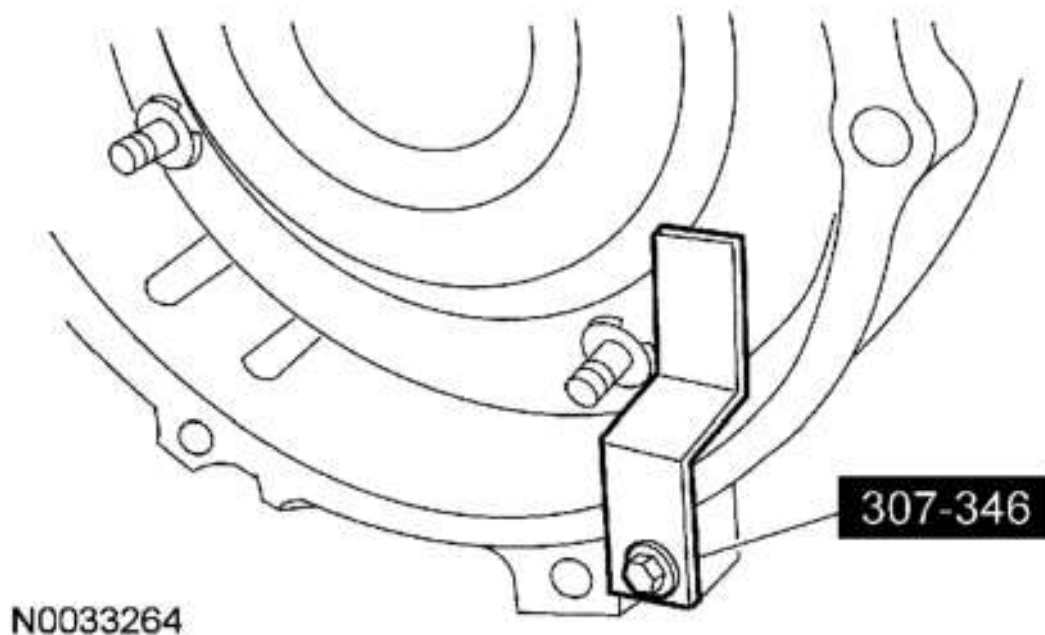

Fig. 351: Installing Special Tool
Courtesy of FORD MOTOR CO.

CAUTION: The converter housing is piloted into position by dowels in the rear of the engine block. The torque converter must rest squarely against the flexplate. This indicates that the converter pilot is not binding in the engine crankshaft.

2. Position and secure the transmission on the high-lift transmission jack. Raise and position the transmission into the vehicle.

NOTE: Make sure the torque converter is fully seated in the transmission before aligning the transmission to the engine.

3. With the transmission in a horizontal position move it toward the engine. Align the orange balancing marks between the torque converter studs and the flexplate bolt holes.

NOTE: Install the transmission bolts in their correct locations noted during removal.

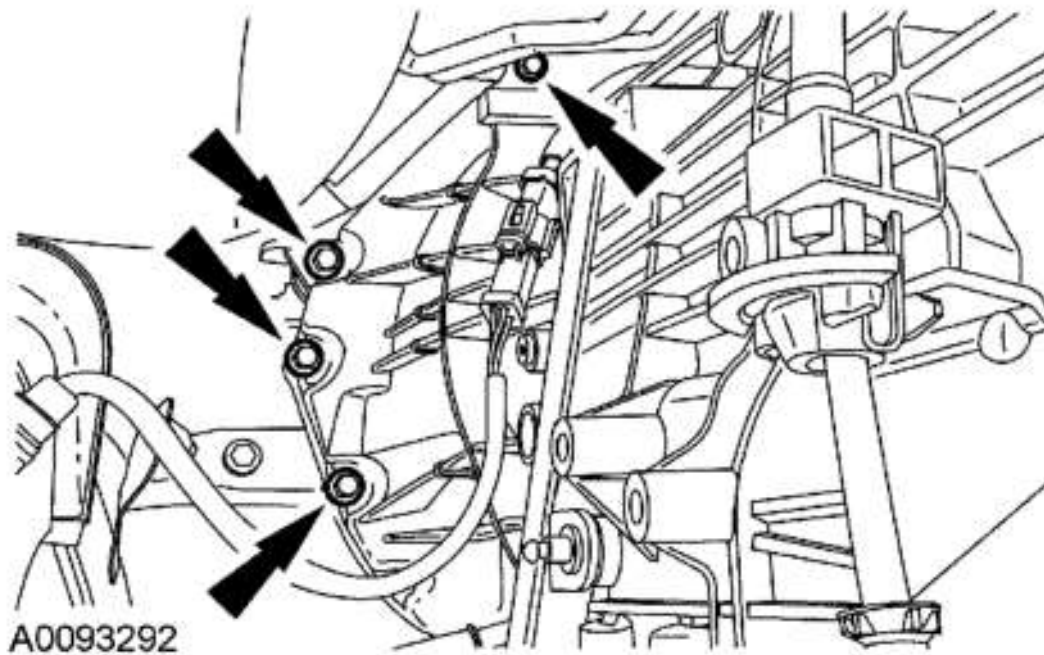
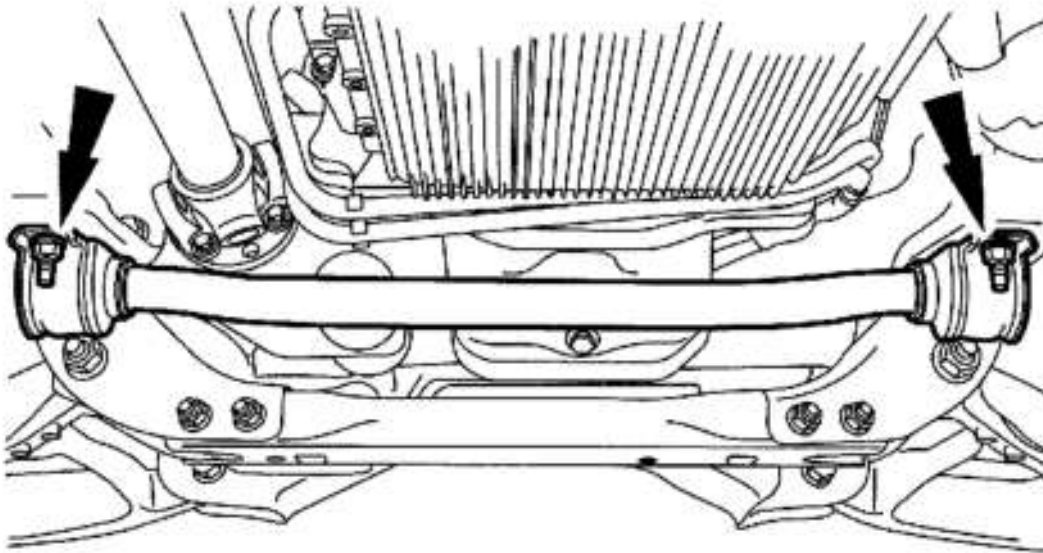

Fig. 352: Installing Transmission-To-Engine Bolts
Courtesy of FORD MOTOR CO.

4. Install the 7 transmission-to-engine bolts.
 - Tighten to 48 Nm (35 lb-ft).
5. Install the front sway bar U-brackets and the bolts.
 - Tighten to 102 Nm (75 lb-ft).



N0011369

Fig. 353: Installing Front Sway Bar U-Brackets
Courtesy of FORD MOTOR CO.

6. Connect the wire harness retainer to the top of the transmission. Connect the main transmission electrical harness by pushing it in and twisting the outer shell to lock it in place.

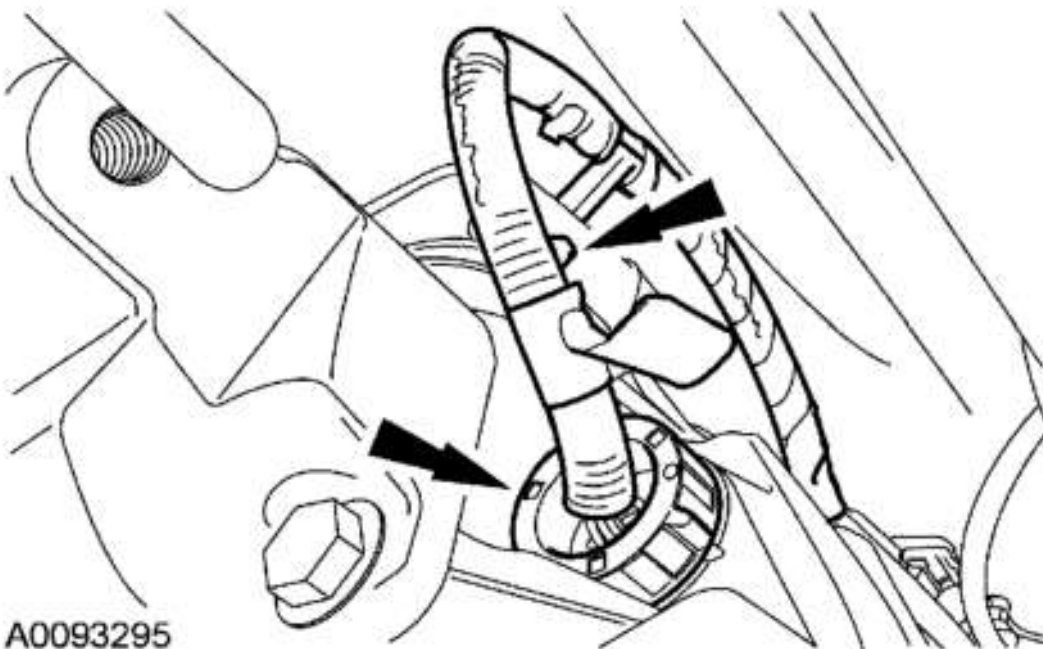

A0093295

Fig. 354: Connecting Wire Harness Retainer
Courtesy of FORD MOTOR CO.

7. Connect the wire harness to the top of the transmission.

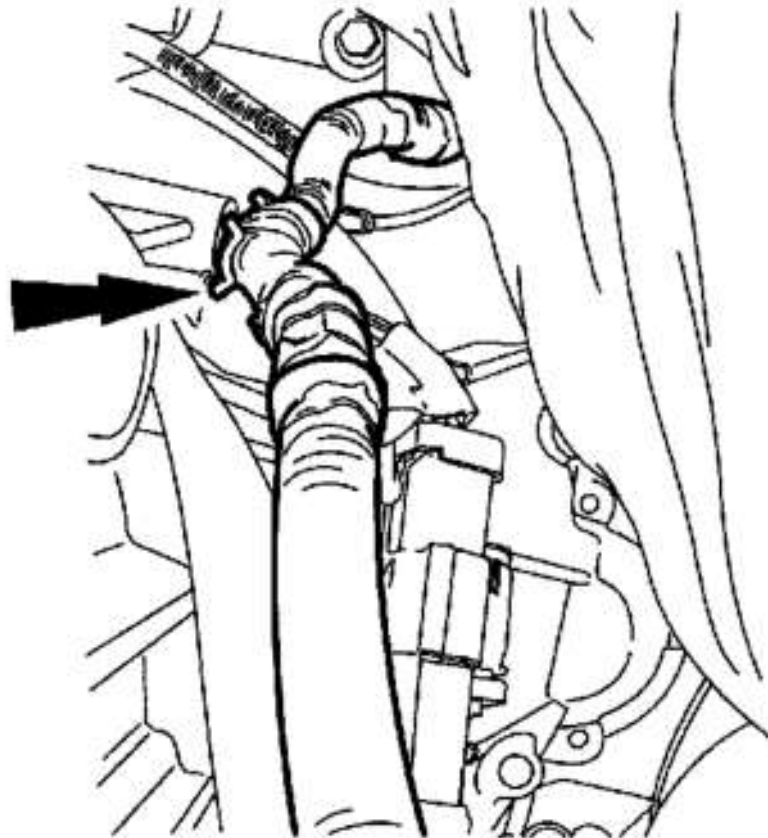

A0093294

Fig. 355: Connecting Wire Harness To Top Of Transmission
Courtesy of FORD MOTOR CO.

8. Connect the RH heated oxygen sensor (HO2S) electrical connector to the side of the transmission.

A0093293

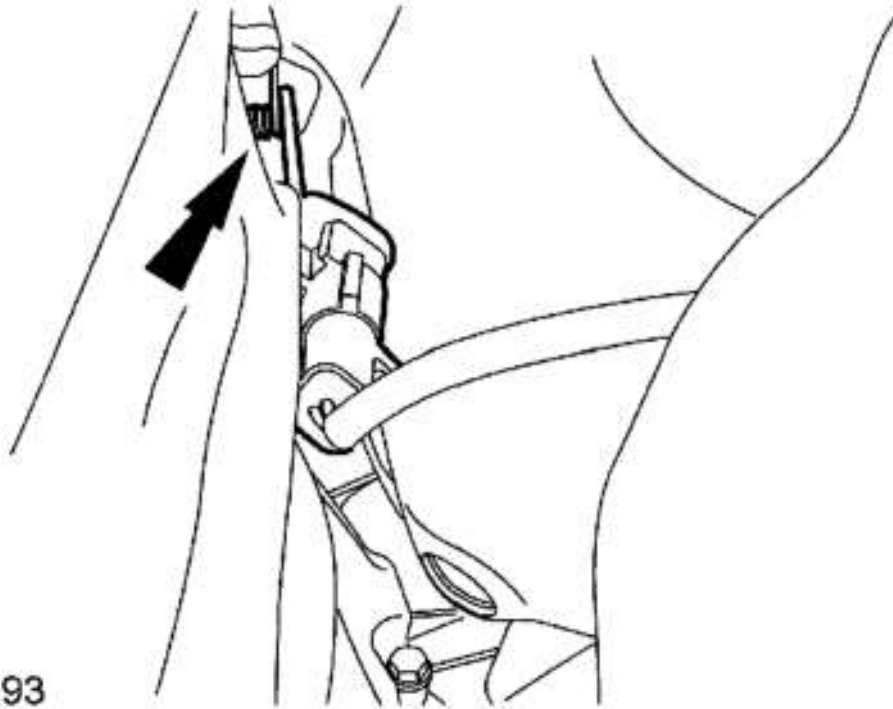

Fig. 356: Connecting RH Heated Oxygen Sensor
Courtesy of FORD MOTOR CO.

9. Connect the LH HO2S electrical connector to the side of the transmission.

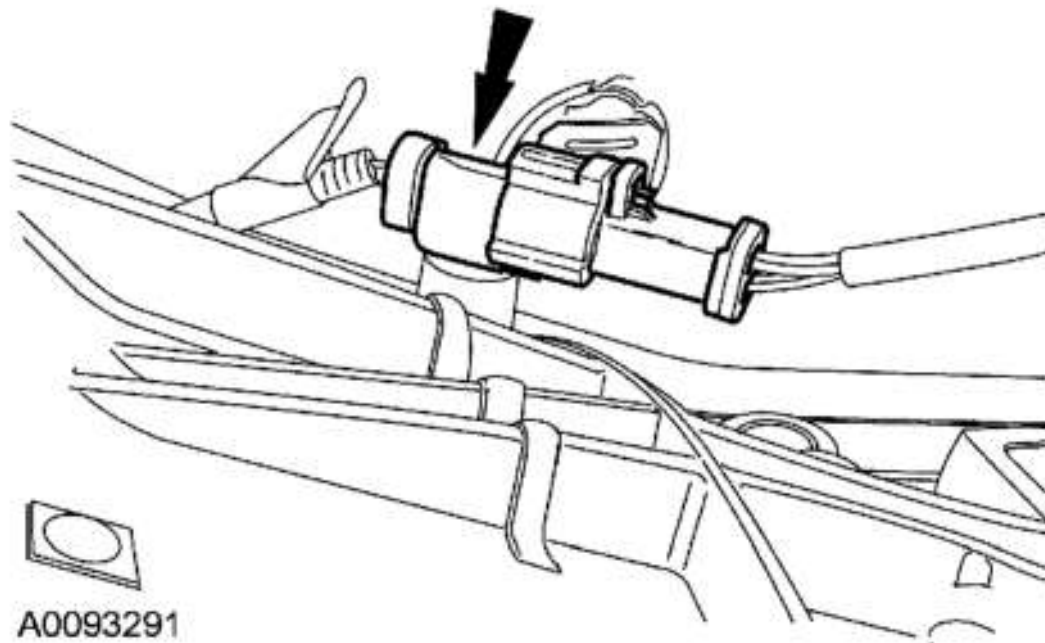

Fig. 357: Connecting LH HO2S Electrical Connector
Courtesy of FORD MOTOR CO.

10. Install the rear transmission mount. Install the LH bolt for the rear transmission support.
 - Tighten to 80 Nm (59 lb-ft).

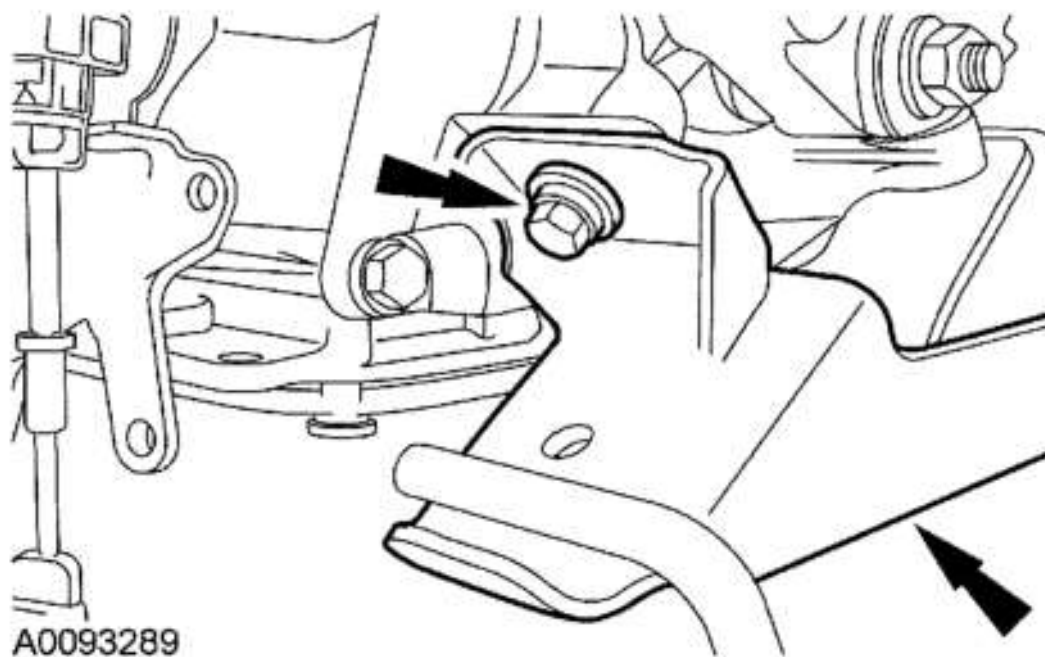

Fig. 358: Installing Rear Transmission Mount
Courtesy of FORD MOTOR CO.

11. Install the RH bolt for the rear transmission support.
 - Tighten to 80 Nm (59 lb-ft).

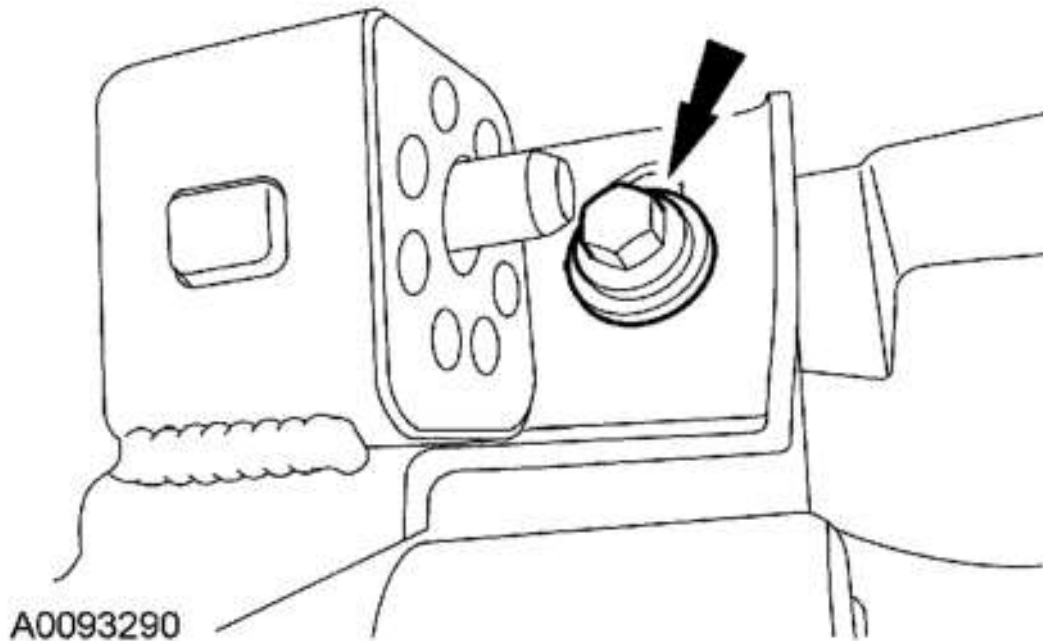

Fig. 359: Installing RH Bolt For Rear Transmission Support
Courtesy of FORD MOTOR CO.

12. Install the exhaust hanger.
 - Tighten to 40 Nm (30 lb-ft).

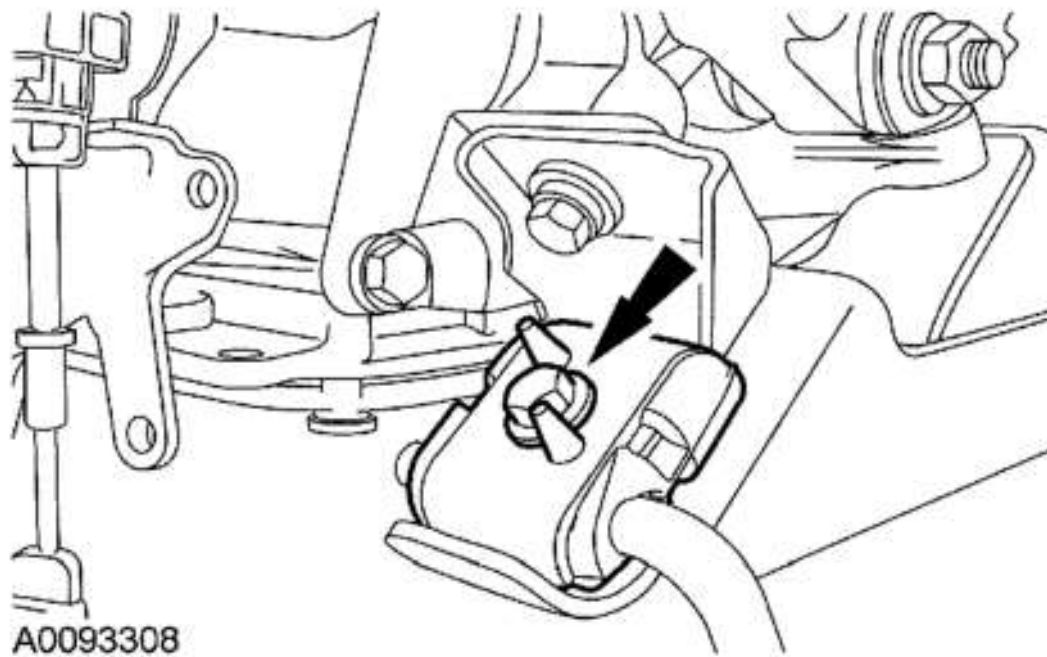

Fig. 360: Installing Exhaust Hanger
Courtesy of FORD MOTOR CO.

13. Position the rear crossmember in place and loosely install the transmission retaining nuts.

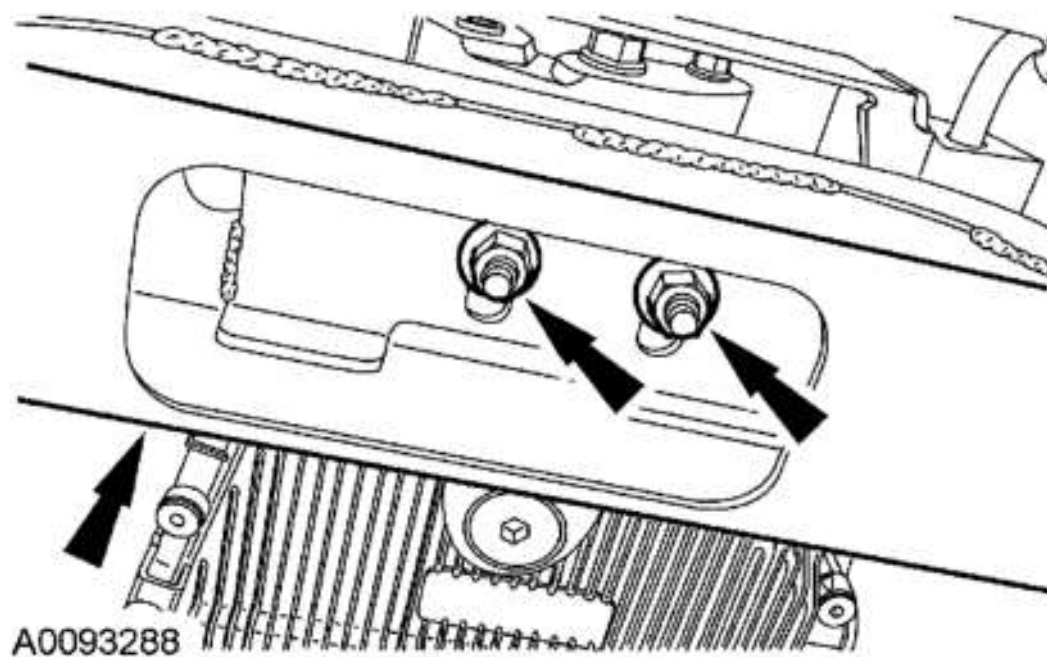

Fig. 361: Installing Transmission Retaining Nuts

Courtesy of FORD MOTOR CO.

14. Install the bolts for the rear crossmember.
 - Tighten to 90 Nm (66 lb-ft).

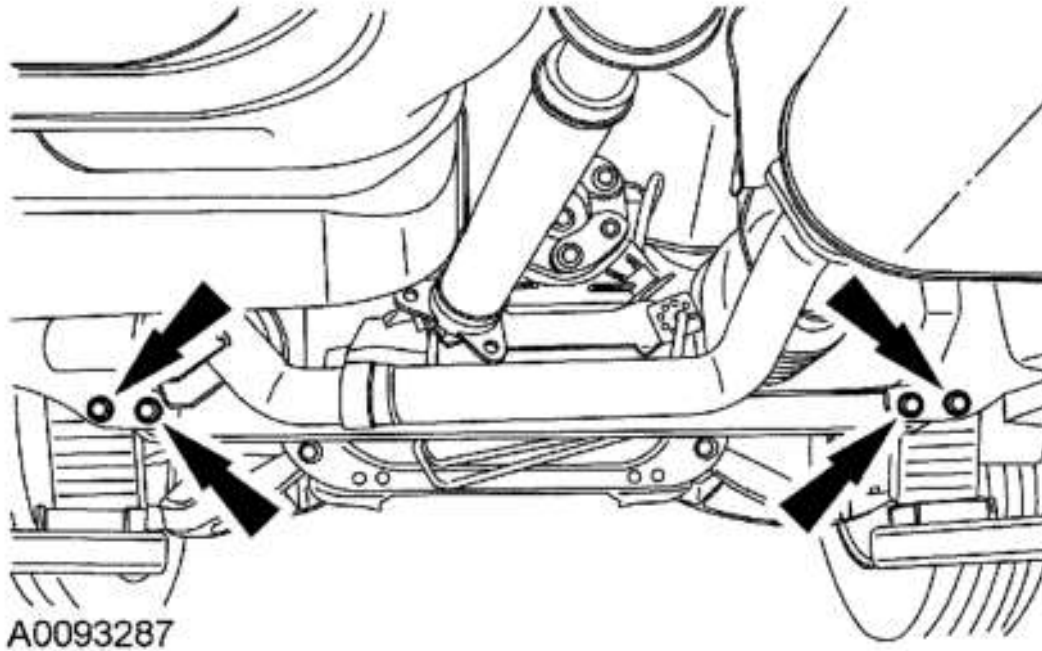

Fig. 362: Installing Bolts For Rear Crossmember
Courtesy of FORD MOTOR CO.

15. Tighten the 2 rear transmission nuts.
 - Tighten to 103 Nm (76 lb-ft).

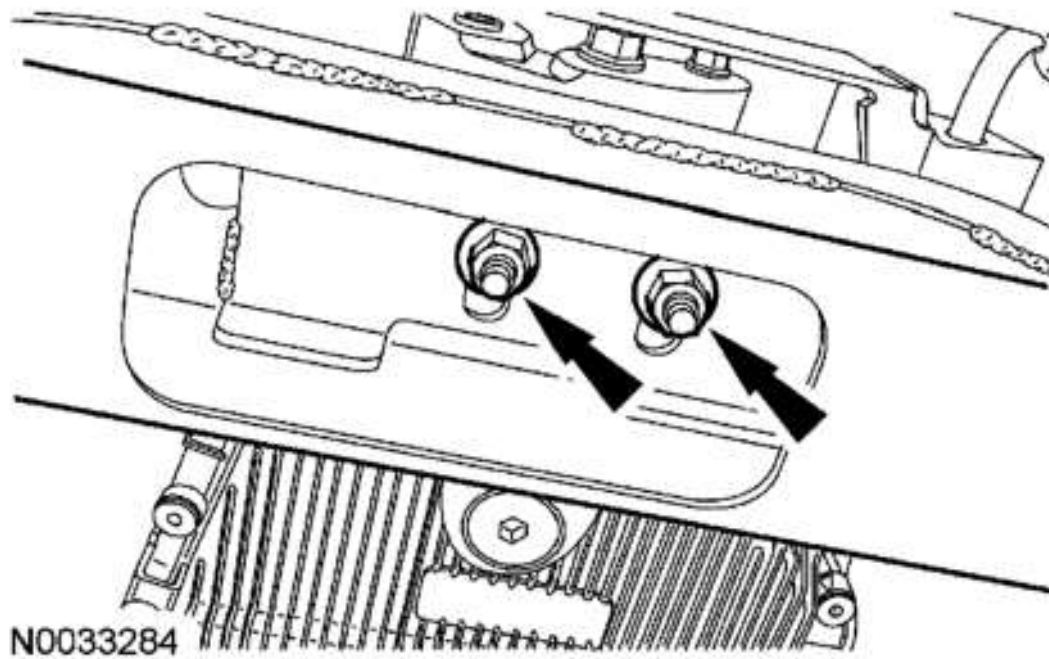

Fig. 363: Tightening Rear Transmission Nuts
Courtesy of FORD MOTOR CO.

16. Install the RH exhaust heat shield bolt.
 - Tighten to 15 Nm (11 lb-ft).

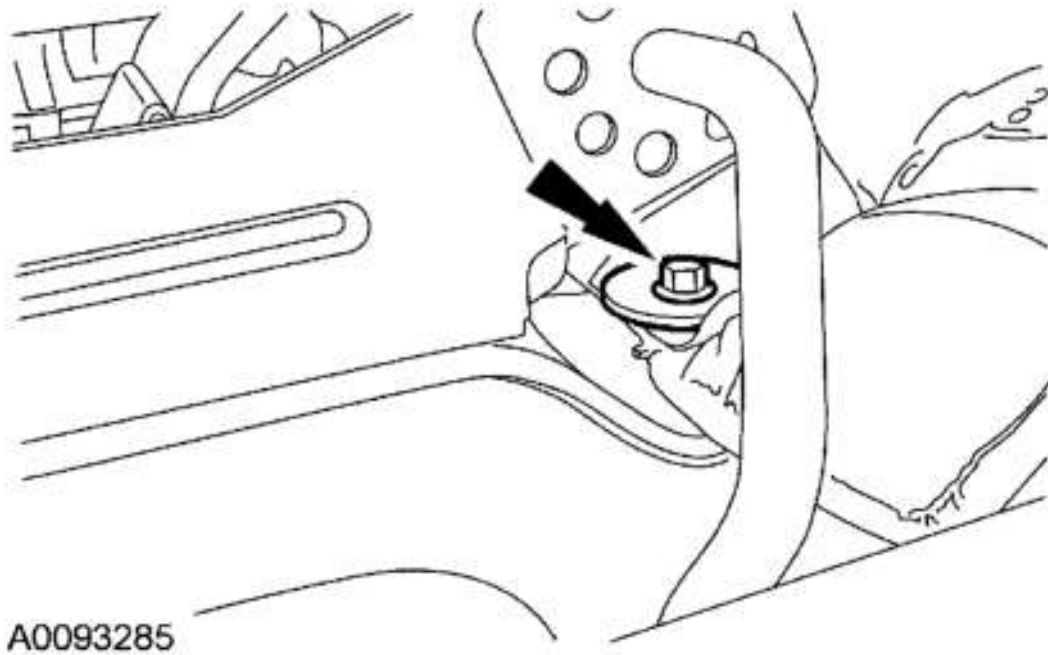

Fig. 364: Installing RH Exhaust Heat Shield Bolt
Courtesy of FORD MOTOR CO.

17. Install the LH exhaust heat shield bolt.
 - Tighten to 15 Nm (11 lb-ft).

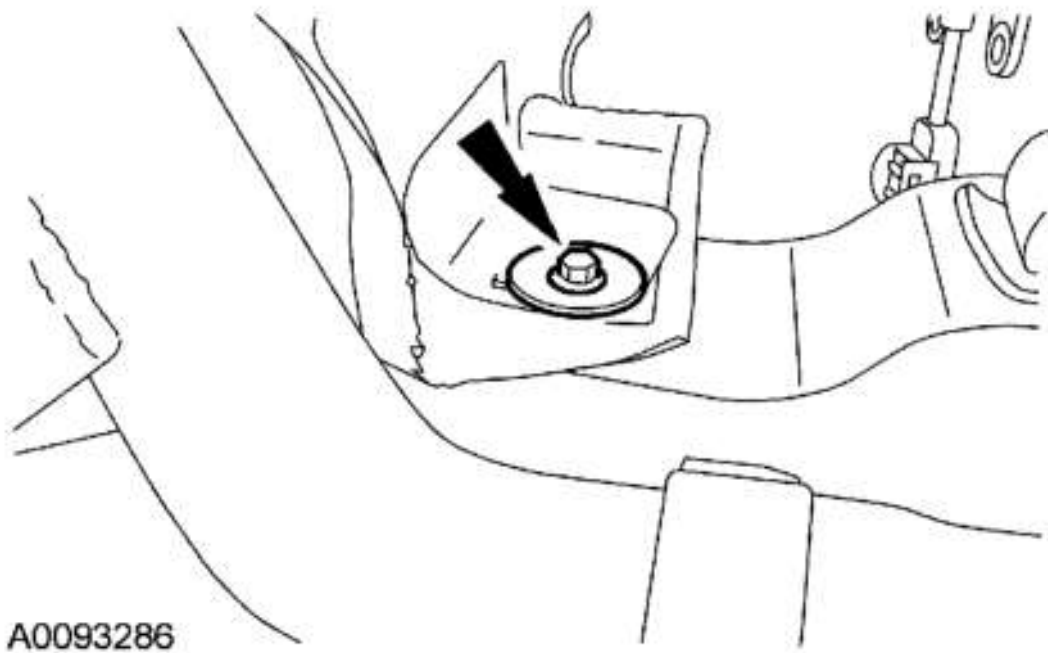

Fig. 365: Installing LH Exhaust Heat Shield Bolt
Courtesy of FORD MOTOR CO.

18. Connect the transmission fluid cooler tubes.

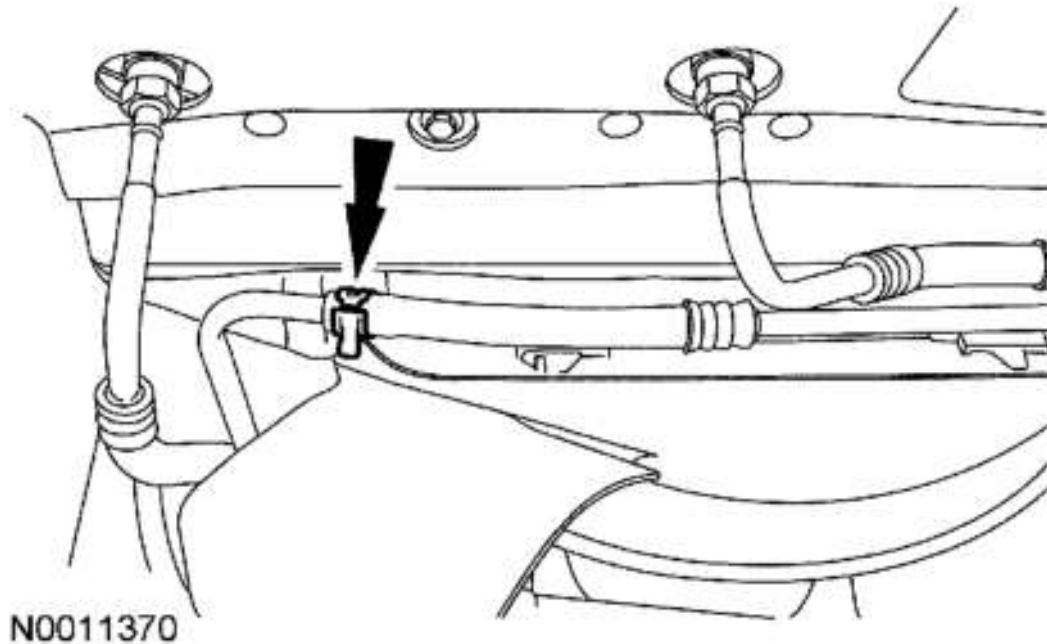

Fig. 366: Connecting Transmission Fluid Cooler Tubes
Courtesy of FORD MOTOR CO.

19. Install the transmission fluid cooler tube bracket and the nut.
 - Tighten to 27 Nm (20 lb-ft).

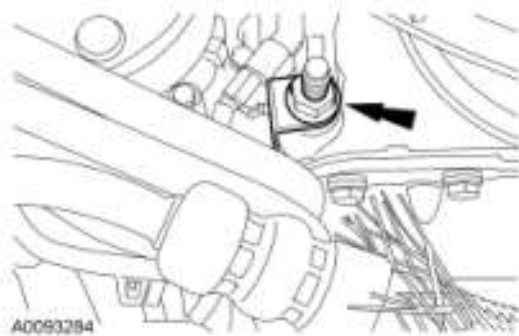

Fig. 367: Identifying Transmission Fluid Cooler Tube Bracket
Courtesy of FORD MOTOR CO.

20. Connect the engine oil level sensor electrical connector.

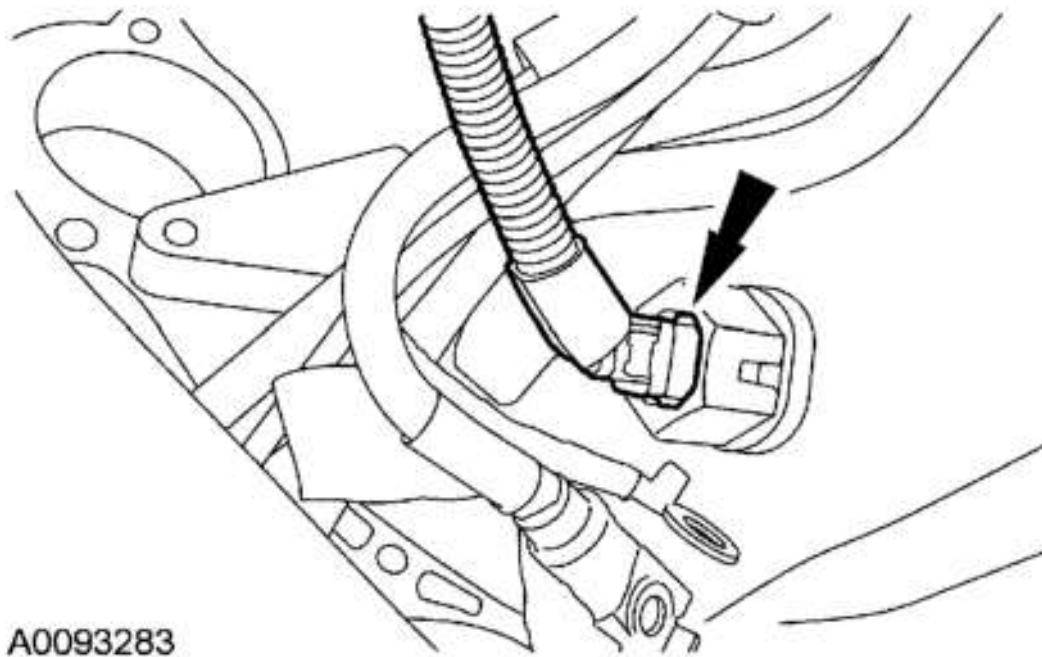

Fig. 368: Connecting Engine Oil Level Sensor Electrical Connector
Courtesy of FORD MOTOR CO.

21. Install the transmission fluid cooler tube retainer and the bolt.
 - Tighten to 48 Nm (35 lb-ft).

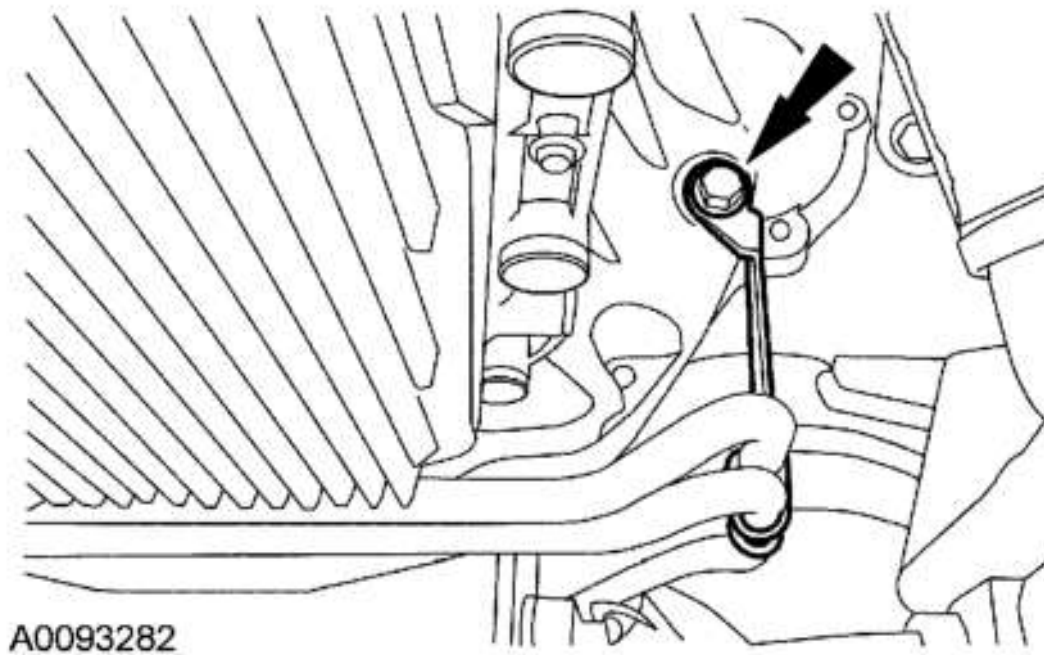
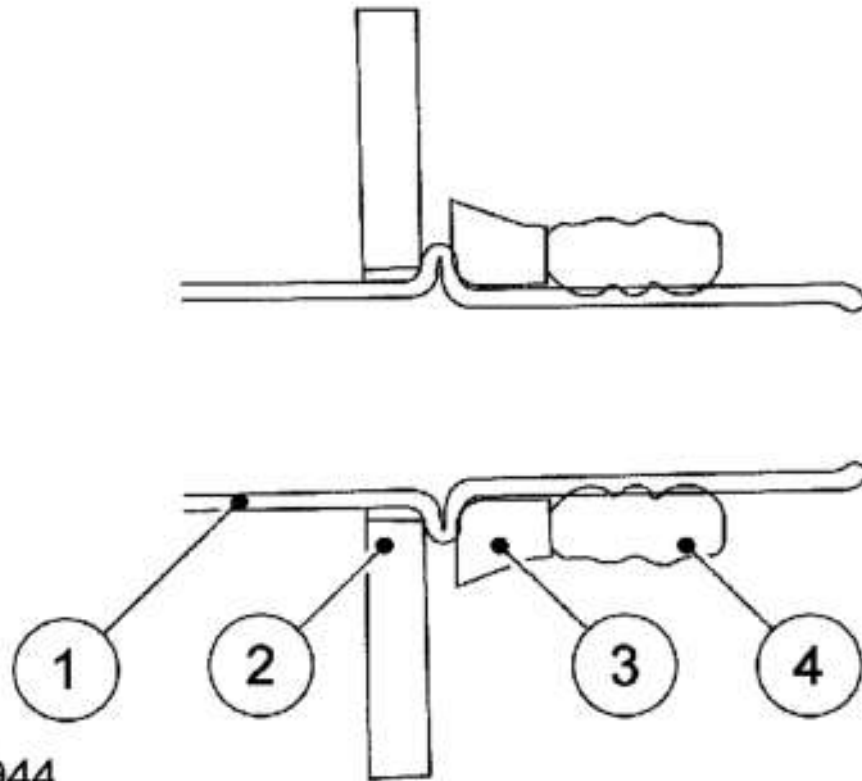

Fig. 369: Installing Transmission Fluid Cooler Tube Retainer
Courtesy of FORD MOTOR CO.

- NOTE:** **Inspect the case to make sure that the old band seals and backer rings are not stuck in the case.**
- NOTE:** **Install new band seals and backer rings on the ends of the cooler tubes prior to installing.**



N0013944

Fig. 370: Installing New Band Seals And Backer Rings
 Courtesy of FORD MOTOR CO.

22. Install new seals on the transmission fluid cooler tubes.
 1. Transmission fluid cooler tube.
 2. Retainer plate.
 3. Backer ring.
 4. Band seal.

NOTE: Inspect the case to make sure that the old band seals and backer rings are not stuck in the case.

NOTE: Install new band seals and backer rings on the ends of the cooler tubes prior to installing.

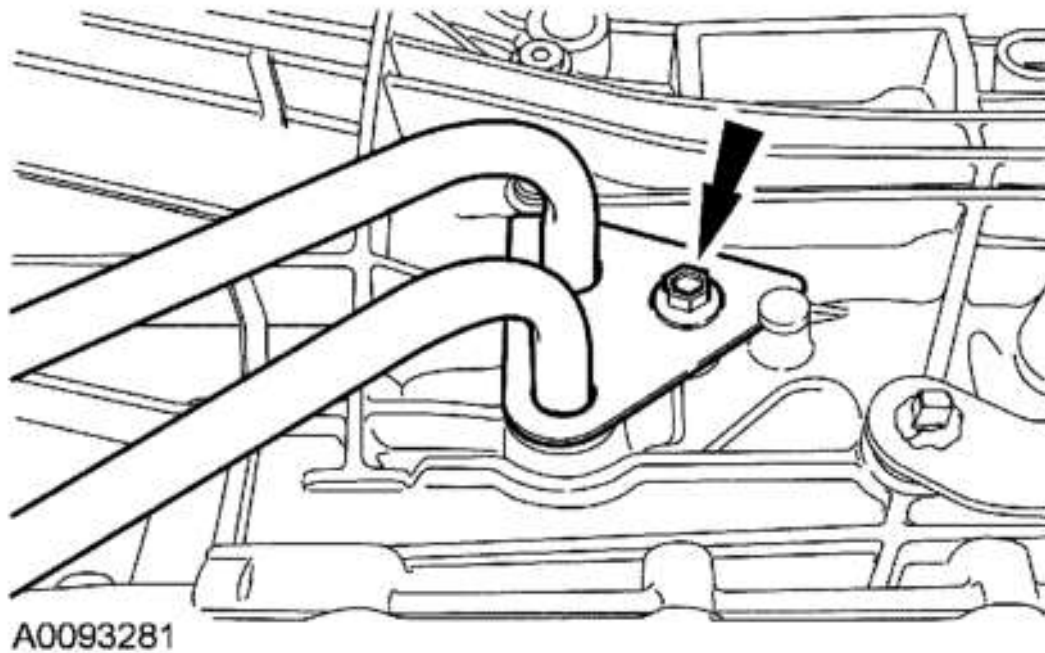

Fig. 371: Installing Transmission Cooler Tube Retainer Bolt
Courtesy of FORD MOTOR CO.

23. Position the fluid cooler tubes into the transmission, then install the bolt for the transmission cooler tube retainer.
 - Tighten to 23 Nm (17 lb-ft).
24. Install the starter motor and the 3 bolts.
 - Tighten to 26 Nm (19 lb-ft).

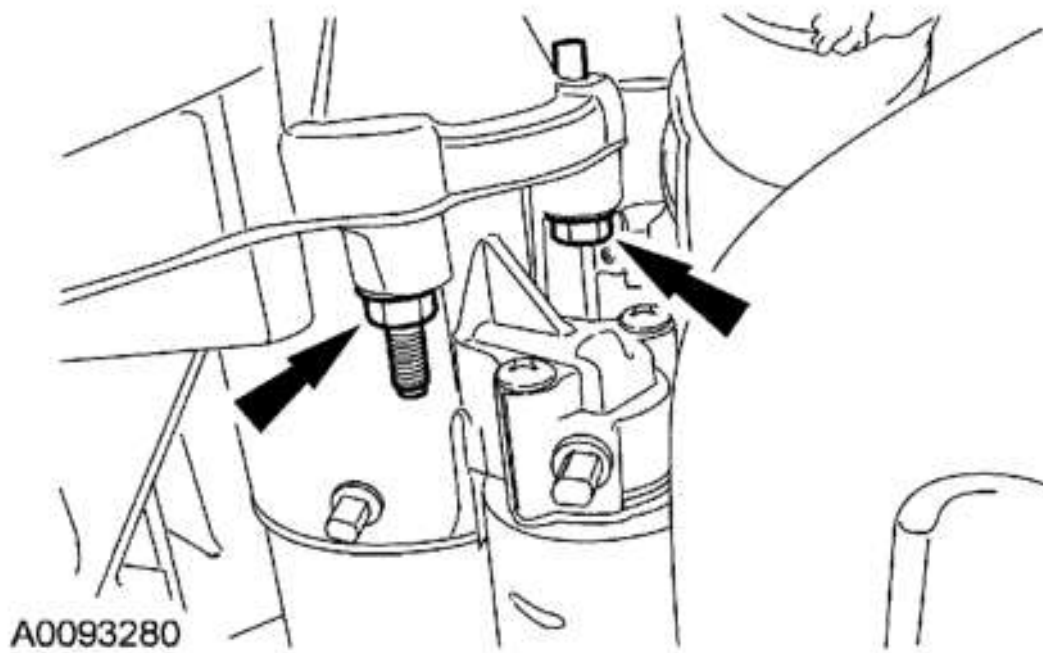

Fig. 372: Installing Starter Motor And Bolts
Courtesy of FORD MOTOR CO.

25. Install the ground wire to the stud.
 - Tighten to 23 Nm (17 lb-ft).

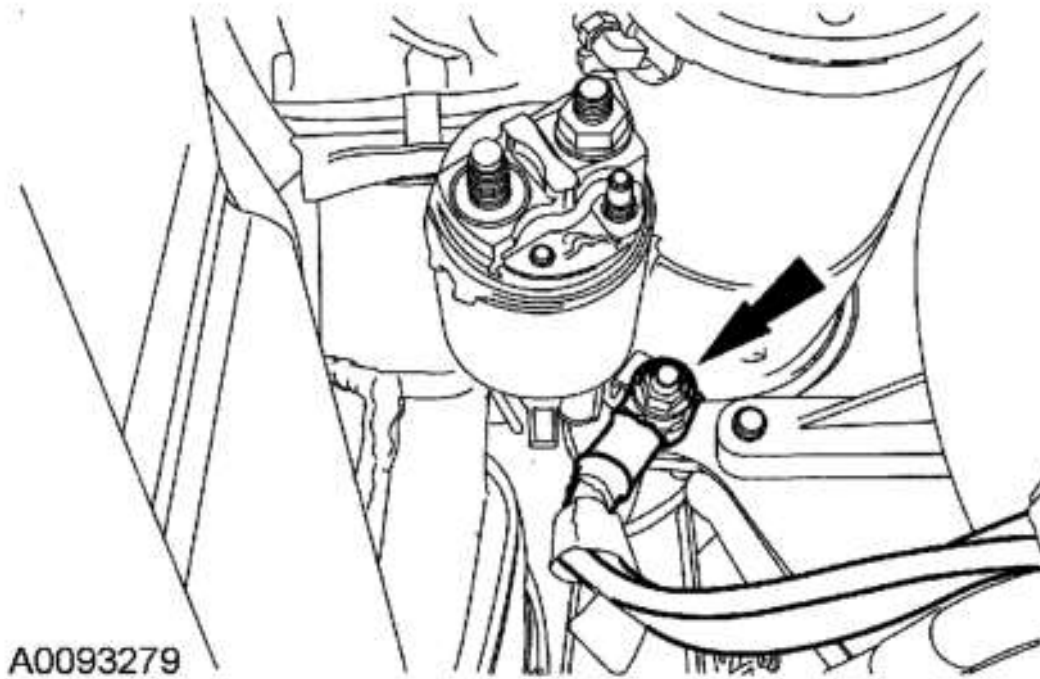

Fig. 373: Installing Ground Wire To Stud
Courtesy of FORD MOTOR CO.

26. Install the starter motor electrical connectors.
 1. Tighten to 12 Nm (9 lb-ft).
 2. Tighten to 6 Nm (53 lb-in).

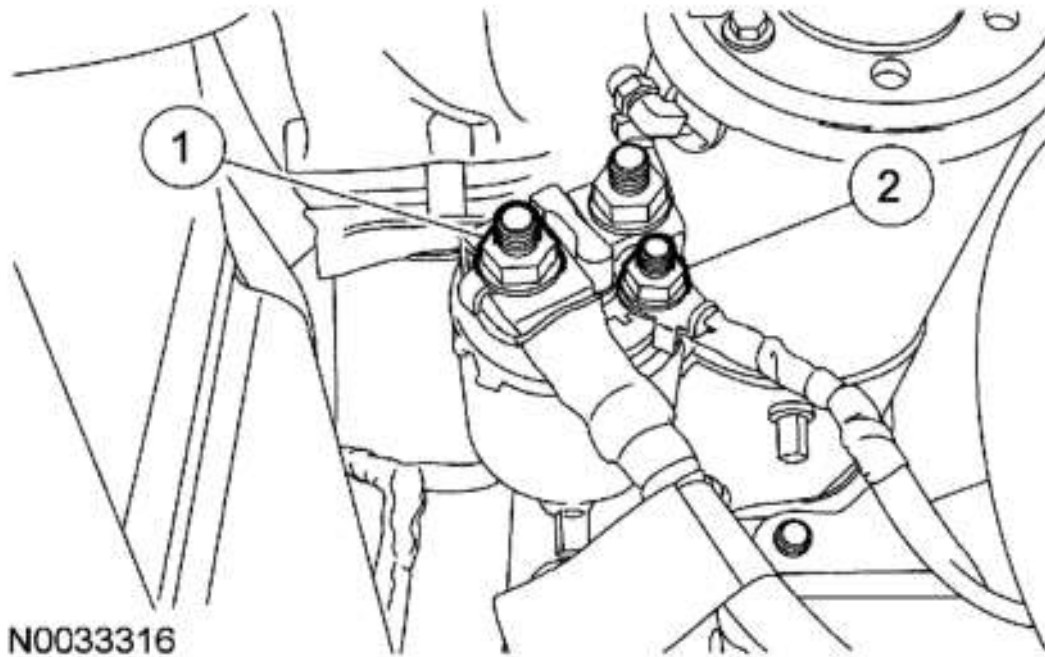

Fig. 374: Installing Starter Motor Electrical Connectors
Courtesy of FORD MOTOR CO.

27. Install the plastic starter motor electrical connector cap.

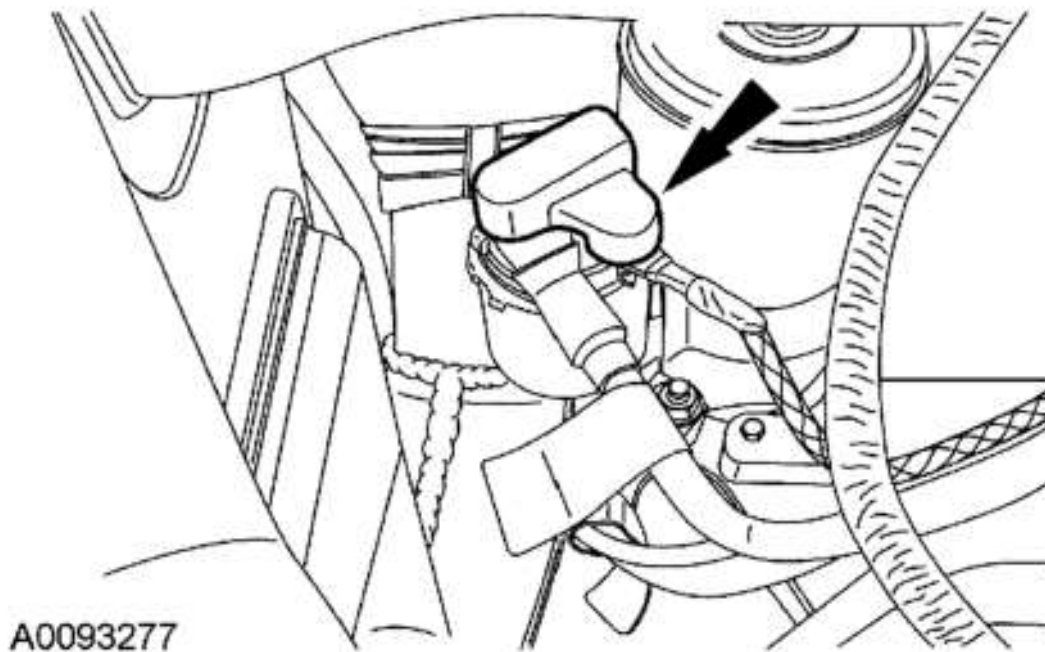

Fig. 375: Installing Plastic Starter Motor Electrical Connector Cap
Courtesy of FORD MOTOR CO.

28. Install 4 new torque converter nuts.
- Rotate the crankshaft to access all the torque converter nuts.
 - Tighten to 35 Nm (26 lb-ft).

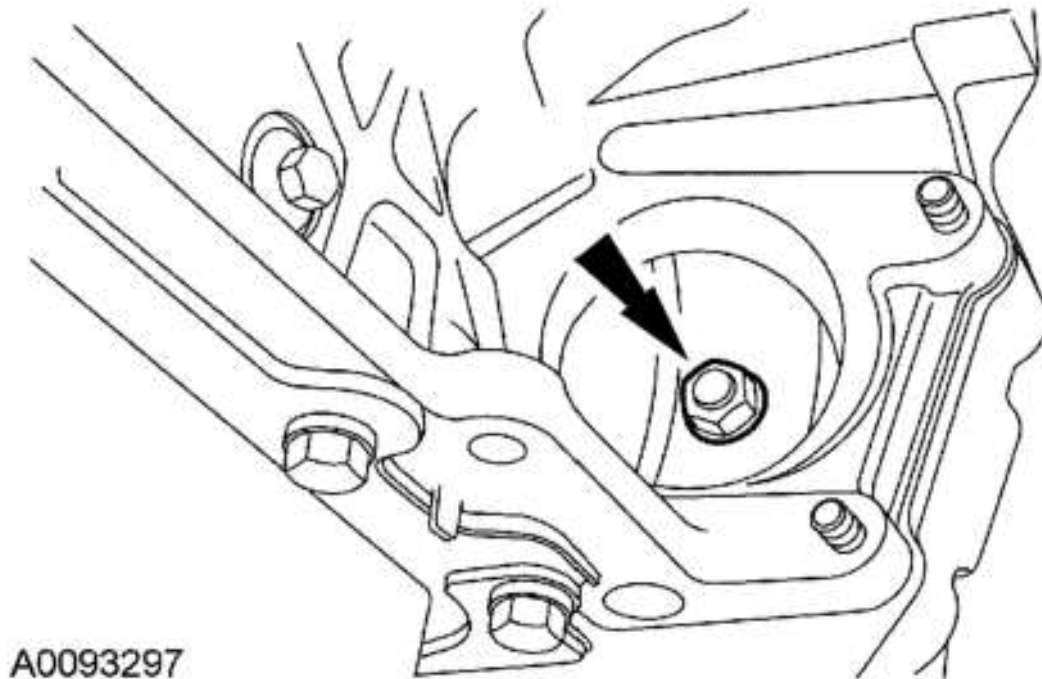
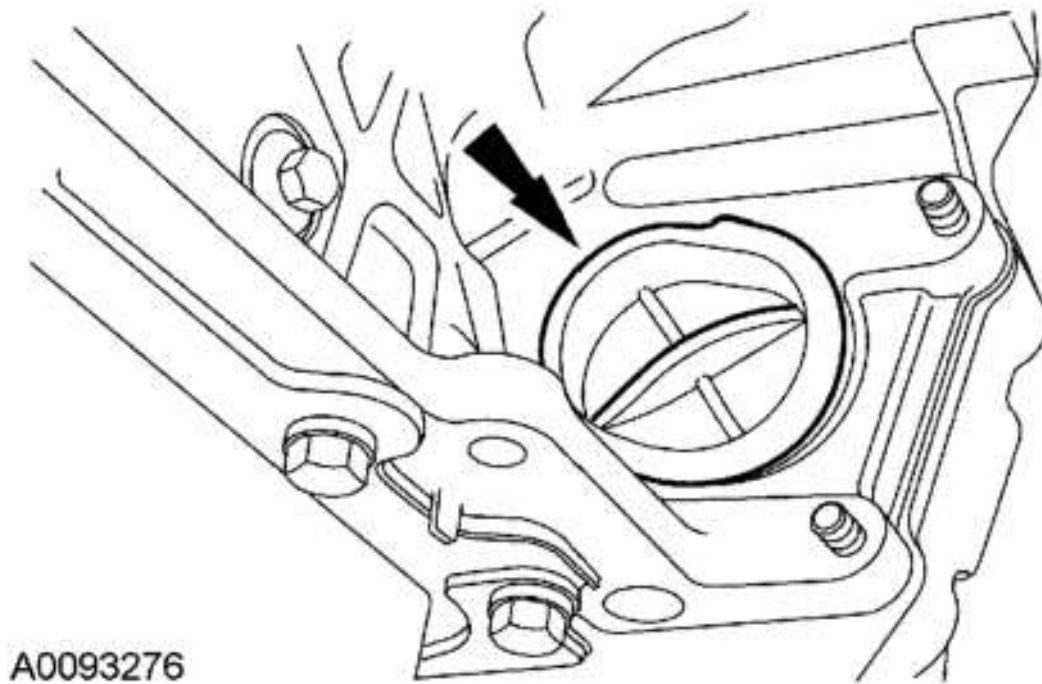

Fig. 376: Installing Torque Converter Nuts
Courtesy of FORD MOTOR CO.

29. Install the rubber access plug.



A0093276

Fig. 377: Installing Rubber Access Plug
Courtesy of FORD MOTOR CO.

30. Install the flexplate inspection cover.
 - Tighten to 35 Nm (26 lb-ft).

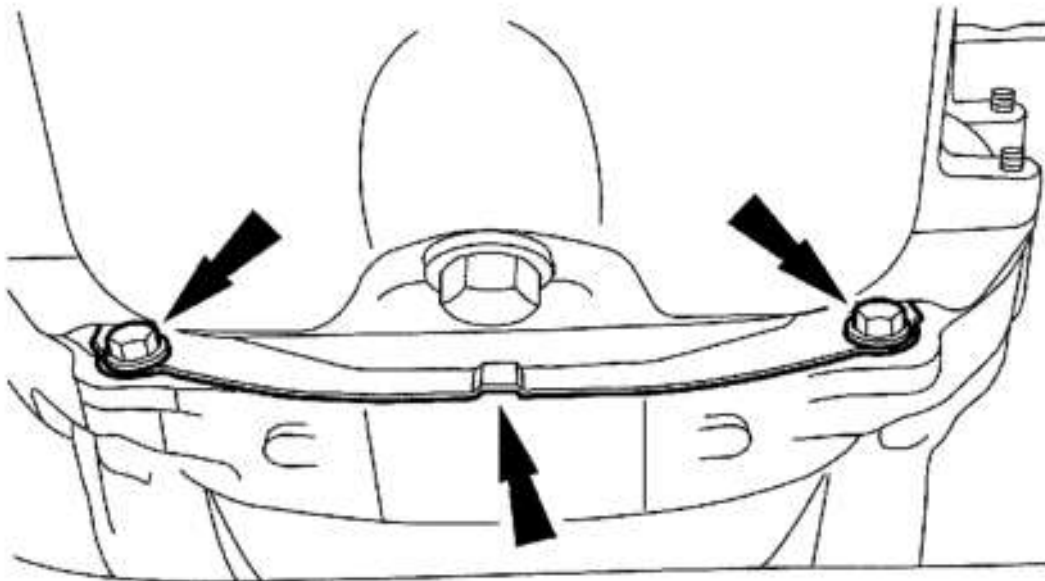

A0093275

Fig. 378: Installing Flexplate Inspection Cover
Courtesy of FORD MOTOR CO.

31. Install the shift cable bracket bolts and connect the shift cable end.
 - Tighten to 48 Nm (35 lb-ft).

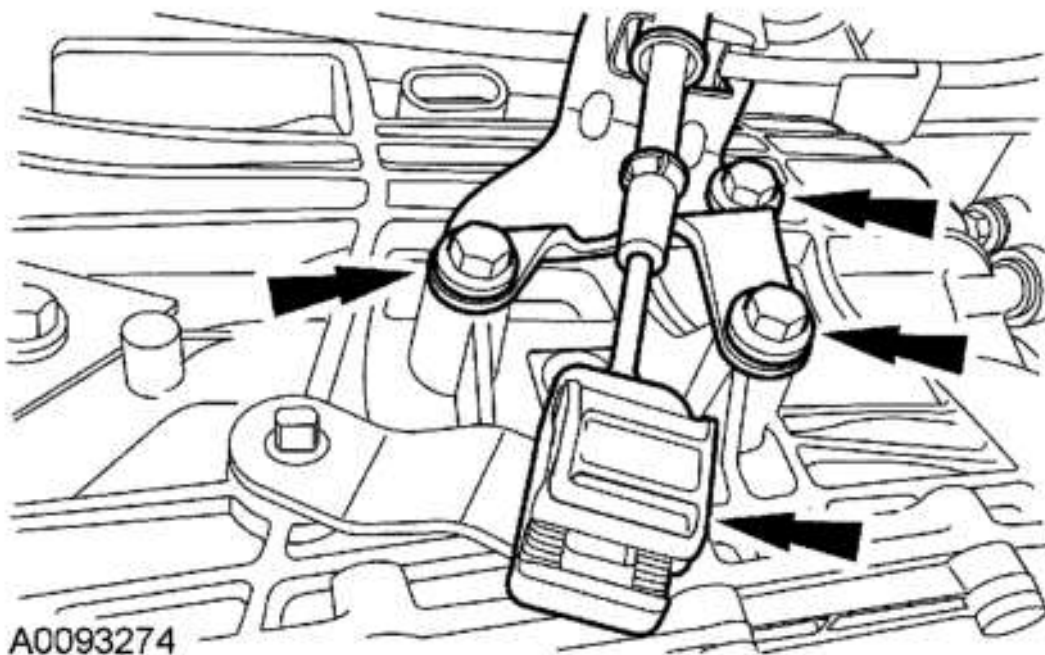

A0093274

Fig. 379: Locating Shift Cable Bracket Bolts
Courtesy of FORD MOTOR CO.

32. Install the fuel line bracket and the bolt.
 - Tighten to 25 Nm (18 lb-ft).

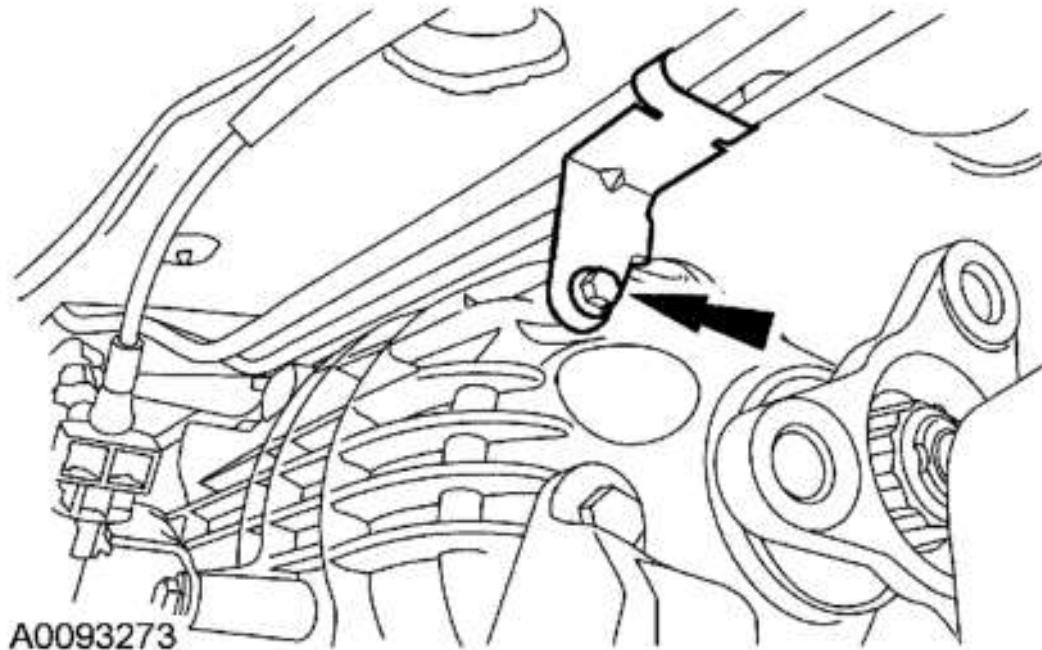

Fig. 380: Installing Fuel Line Bracket
Courtesy of FORD MOTOR CO.

33. Connect the battery ground cable.

CAUTION: The fluid fill plug located on the side of the transmission is near the exhaust system. The exhaust will be extremely hot during this procedure. Use care when working near the exhaust and the heat shields.

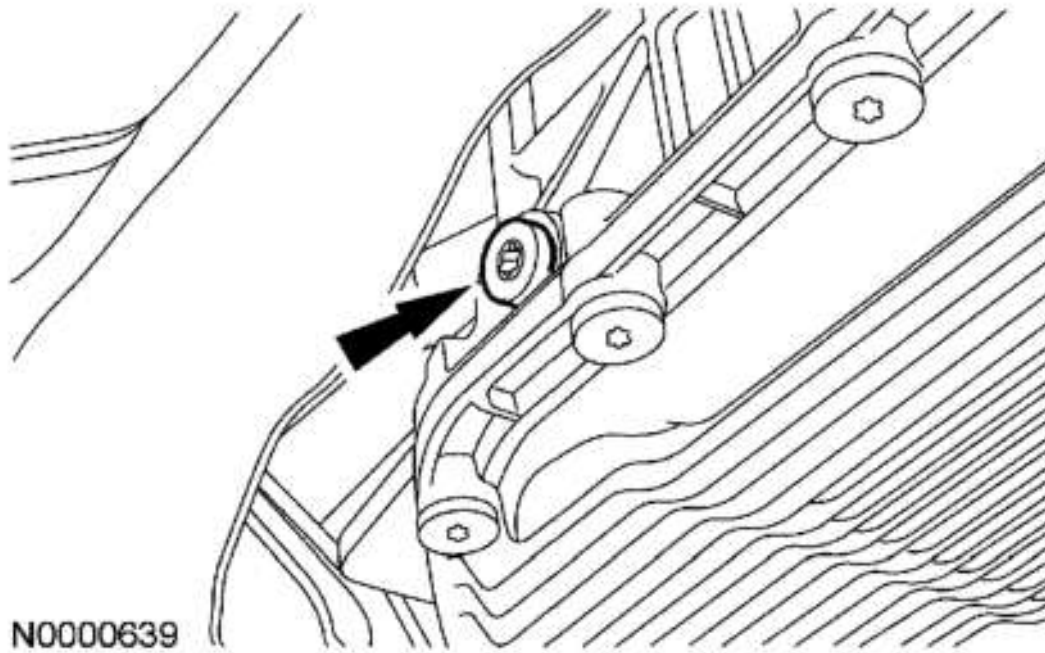

Fig. 381: Locating Fill Plug
Courtesy of FORD MOTOR CO.

34. Remove the fluid fill plug.
 - The fill plug is located on the RH rear side of the case near the transmission electrical connector.

CAUTION: The use of any other transmission fluid than specified, can result in the transmission failing to operate correctly or transmission failure.

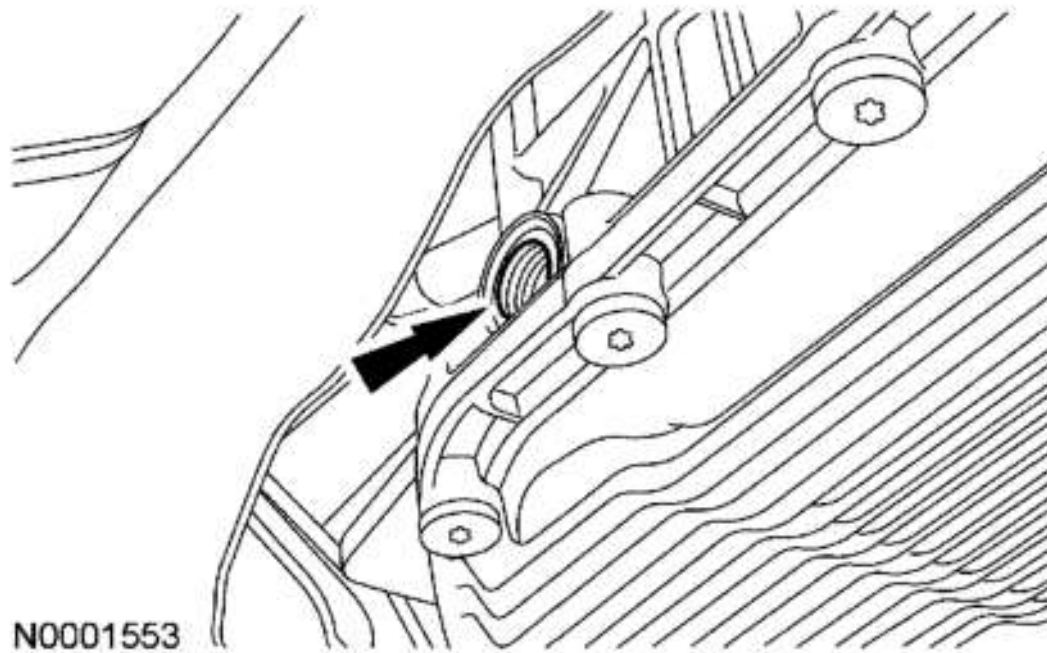

Fig. 382: Locating Fluid Fill Plug
Courtesy of FORD MOTOR CO.

35. Fill the transmission.
 - Add 4.7 liters (5 quarts) of clean automatic transmission fluid to the transmission through the fluid fill hole. Stop when the fluid runs out of the bottom of the hole.
36. Install the fluid fill plug.
 - Tighten to 35 Nm (26 lb-ft).

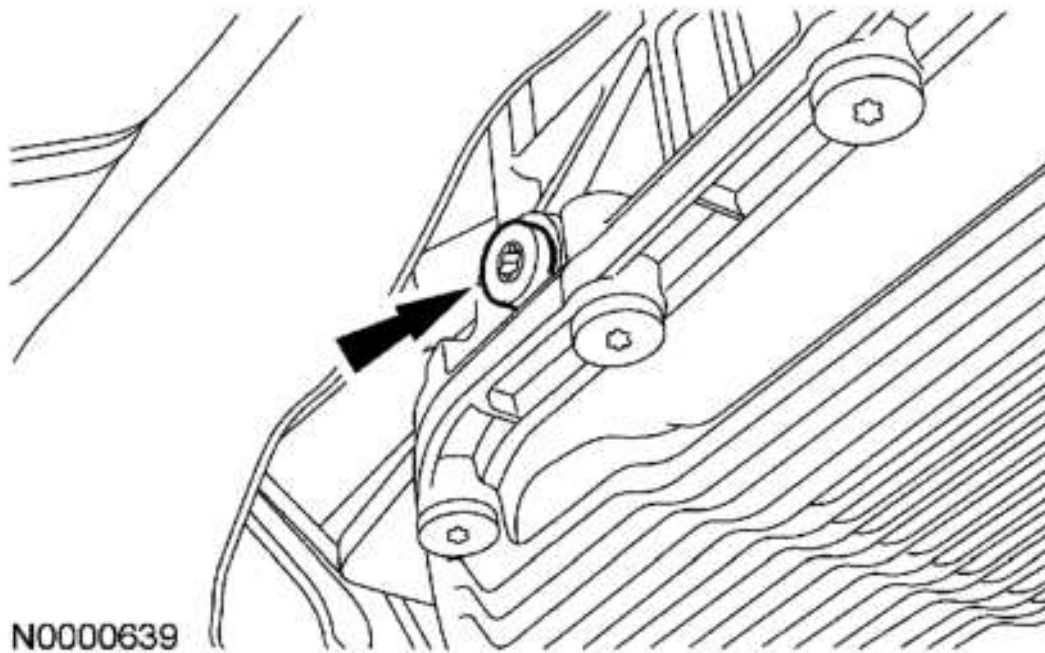

Fig. 383: Installing Fill Plug
Courtesy of FORD MOTOR CO.

37. Verify that the shift cable is correctly adjusted. For additional information, refer to **AUTOMATIC TRANSAXLE/TRANSMISSION EXTERNAL CONTROLS** .
38. Re-flash the transmission control module (TCM) to the latest level of software.
39. Start the engine. Move the transmission range selector lever through all the gear ranges, checking for engagements.
40. With the engine idling (600-750 rpm) in PARK and the transmission temperature at 30°C-50°C (86° F-122°F), check and adjust the transmission fluid level.

CAUTION: The fluid fill plug located on the side of the transmission is near the exhaust system. The exhaust will be extremely hot during this procedure. Use care when working near the exhaust and the heat shields.

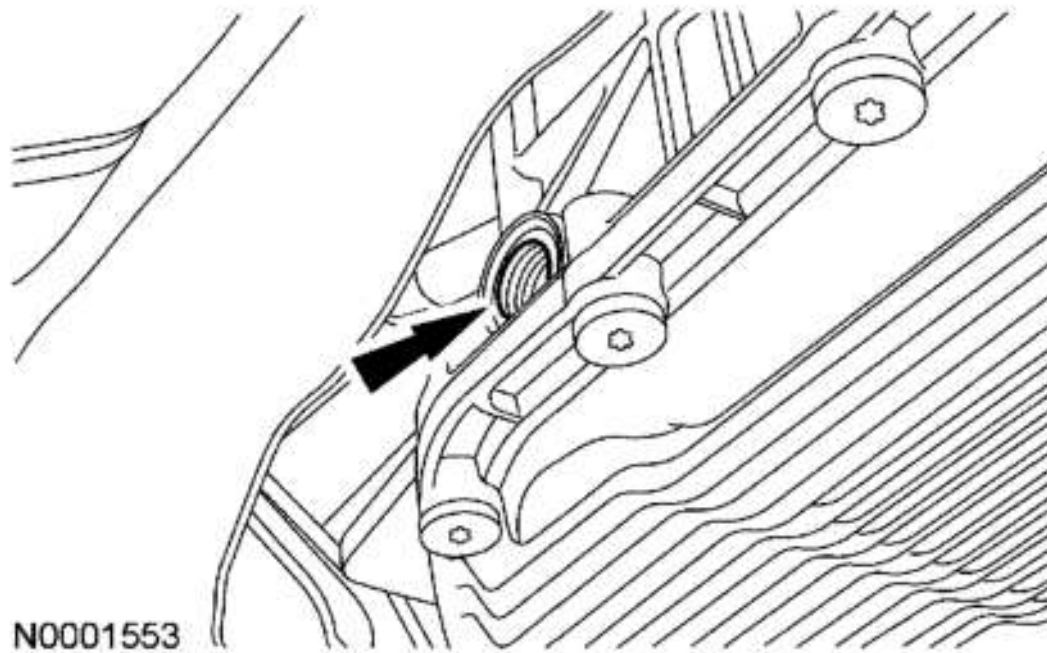

Fig. 384: Locating Fluid Fill Plug
Courtesy of FORD MOTOR CO.

41. With the engine still running in PARK, check the fluid level. If more fluid is needed, remove the fluid fill plug on the side of the case and fill with clean automatic transmission fluid until the fluid runs out of the bottom of the hole.
42. Install the fluid fill plug.
 - Tighten to 35 Nm (26 lb-ft).

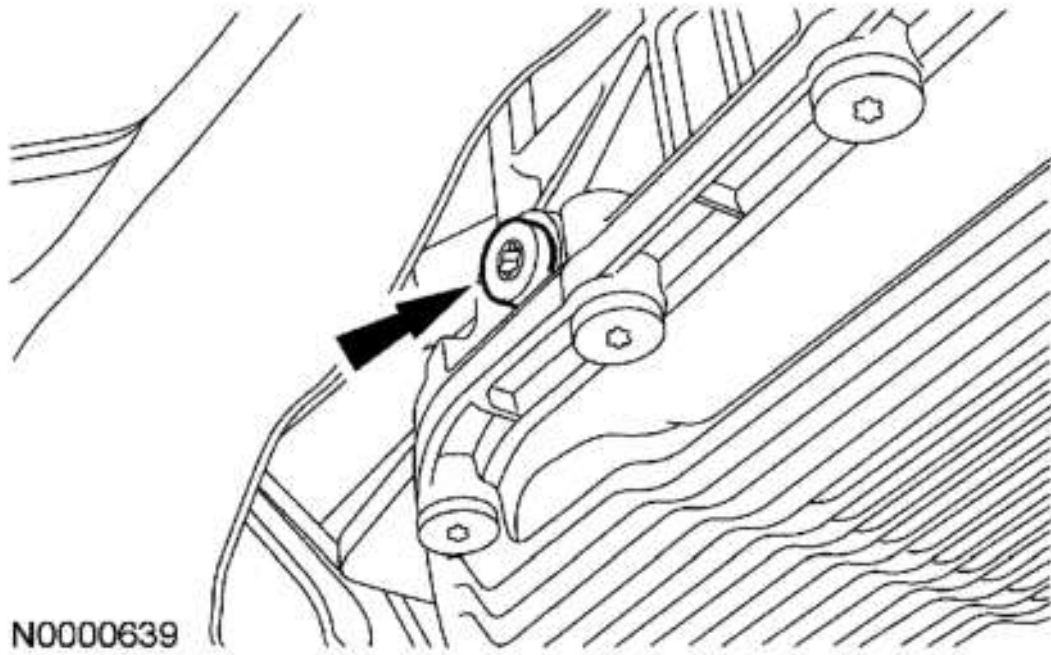

Fig. 385: Installing Fill Plug
Courtesy of FORD MOTOR CO.