

# Converter System

## Table of Contents

Exploded View.....	6-2
Specifications .....	6-6
Special Tools .....	6-7
Torque Converter.....	6-9
Torque Converter Cover Removal .....	6-9
Torque Converter Cover Installation .....	6-10
Torque Converter Cover Disassembly .....	6-10
Actuator Lever (Engine Brake Control Lever) Assembly Inspection .....	6-11
Torque Converter Cover Assembly .....	6-11
Drive Belt.....	6-13
Drive Belt Removal .....	6-13
Drive Belt Installation .....	6-13
Drive Belt Deflection Inspection.....	6-13
Drive Belt Deflection Adjustment .....	6-13
Drive Belt Inspection.....	6-13
Drive Pulley .....	6-14
Drive Pulley Removal.....	6-14
Drive Pulley Disassembly .....	6-14
Drive Pulley Inspection .....	6-15
Spider Shoe Side Clearance Adjustment.....	6-17
Drive Pulley Assembly .....	6-18
Drive Pulley Installation.....	6-19
Driven Pulley .....	6-21
Driven Pulley Removal.....	6-21
Driven Pulley Disassembly .....	6-21
Driven Pulley Inspection .....	6-22
Driven Pulley Assembly .....	6-23
Driven Pulley Installation.....	6-25
High Altitude Setting Information.....	6-27
Specifications.....	6-27

# 6-2 CONVERTER SYSTEM

## Exploded View

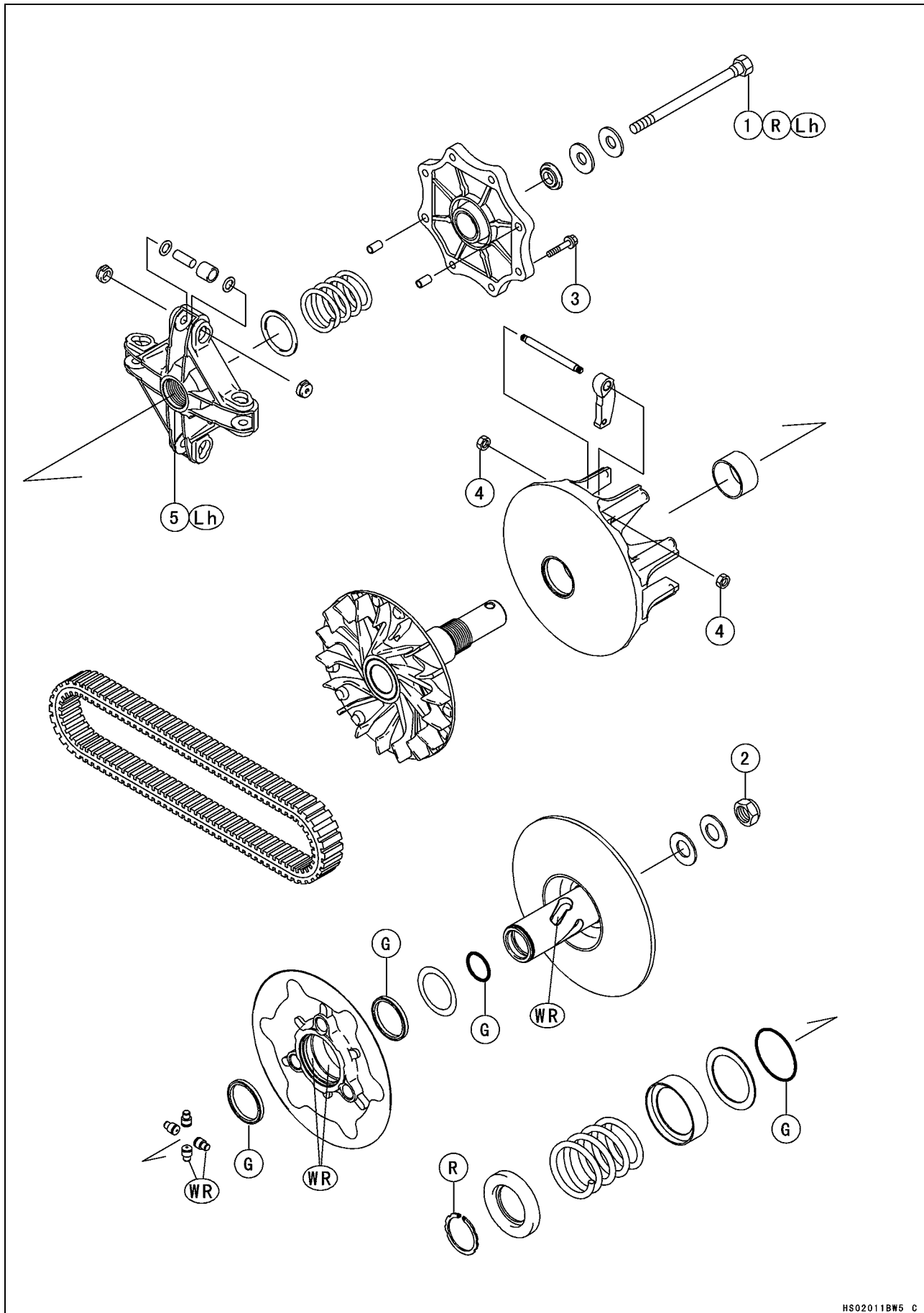

## CONVERTER SYSTEM 6-3

### Exploded View

No.	Fastener	Torque			Remarks
		N·m	kgf·m	ft·lb	
1	Drive Pulley Bolt	93	9.5	69	R, Lh
2	Driven Pulley Nut	93	9.5	69	
3	Drive Pulley Cover Bolts	13	1.3	113 in·lb	
4	Ramp Weight Nuts	6.9	0.70	61 in·lb	
5	Spider	275	28	203	Lh

G: Apply grease.

Lh: Left-hand Threads

R: Replacement Parts

WR: Apply grease (WR500-No.2 KYODO YUSHI, POWER LITE WR #2 KYODO YUSHI, or SERAN -HV TOTAL FINA).

# 6-4 CONVERTER SYSTEM

## Exploded View

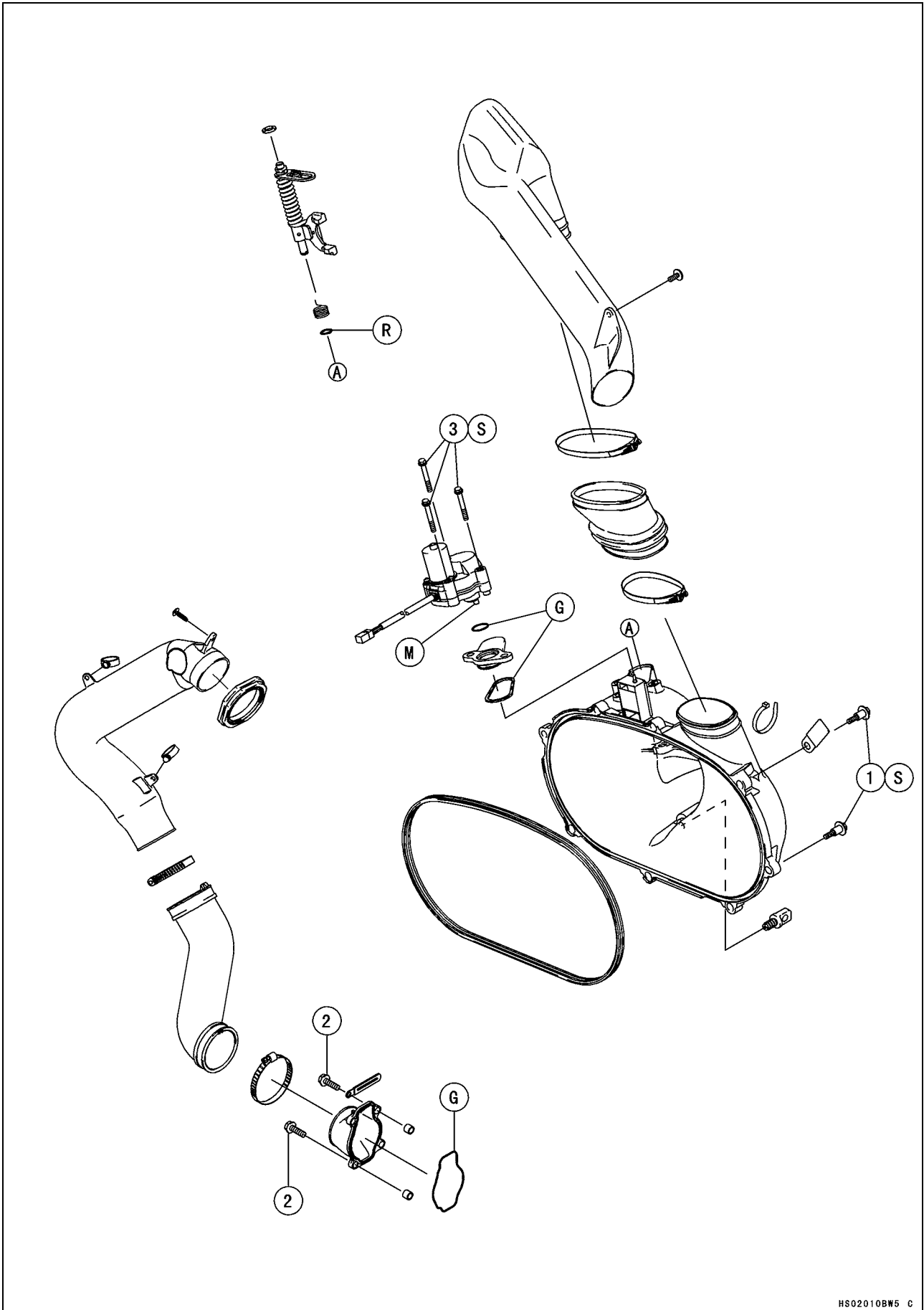

## CONVERTER SYSTEM 6-5

### Exploded View

No.	Fastener	Torque			Remarks
		N·m	kgf·m	ft·lb	
1	Converter Cover Bolts	8.8	0.90	78 in·lb	S
2	Joint Duct Bolts	8.8	0.90	78 in·lb	
3	Engine Brake Actuator Mounting Bolts	8.8	0.90	78 in·lb	S

G: Apply grease.

M: Apply molybdenum disulfide grease.

R: Replacement Part

S: Follow the specific tightening sequence.

## 6-6 CONVERTER SYSTEM

### Specifications

Item	Standard	Service Limit
<b>Torque Converter</b>		
Actuator Lever Guide Shoe	---	6 mm (0.24 in.)
<b>Drive Belt</b>		
Belt Width	29.7 ~ 30.3 mm (1.169 ~ 1.193 in.)	28.0 mm (1.102 in.)
Belt Deflection	22 ~ 27 mm (0.87 ~ 1.06 in.)	---
<b>Drive Pulley</b>		
Shoe Side Clearance	Up to 0.20 mm (0.008 in.) (in the text)	---
Cover Bushing Inside Diameter	27.985 ~ 28.085 mm (1.1018 ~ 1.1057 in.)	28.12 mm (1.107 in.)
Sheave Bushing Inside Diameter	37.985 ~ 38.085 mm (1.4955 ~ 1.4994 in.)	38.12 mm (1.501 in.)
Spring Free Length	60.4 mm (2.38 in.)	---
<b>Driven Pulley</b>		
Sheave Bushing Inside Diameter	40.000 ~ 40.039 mm (1.5748 ~ 1.5763 in.)	40.07 mm (1.578 in.)
Spring Free Length	99.5 mm (3.92 in.)	---

## Special Tools

**Circlip Pliers:**  
57001-154

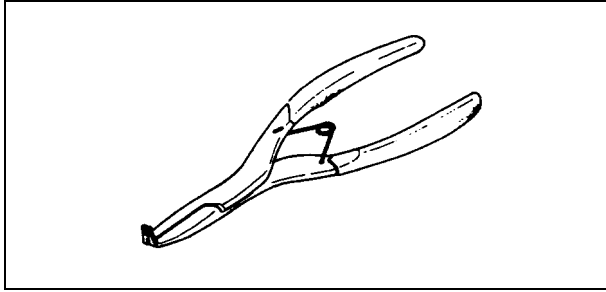

**Flywheel & Pulley Holder:**  
57001-1343

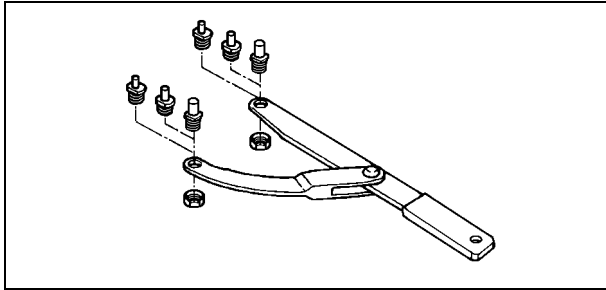

**Drive & Driven Pulley Holder:**  
57001-1412

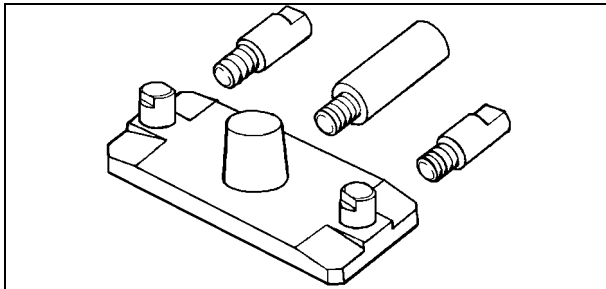

**Drive Pulley Puller Bolt:**  
57001-1429

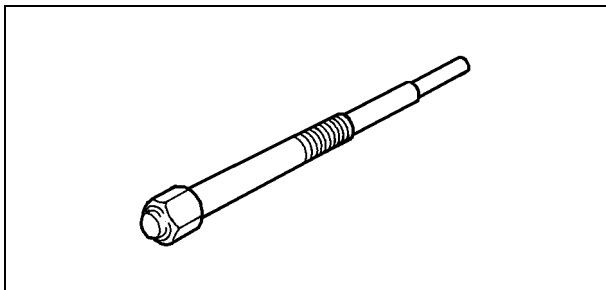

**Pulley Holder Attachment:**  
57001-1472

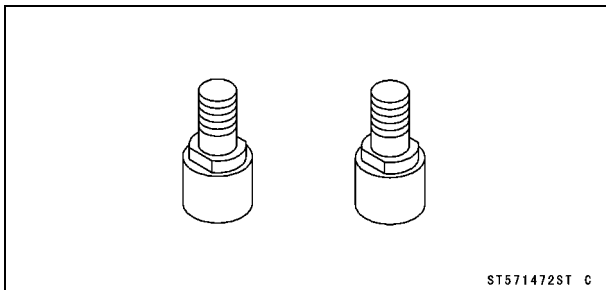

ST571472ST C

**Drive & Driven Pulley Holder:**  
57001-1473

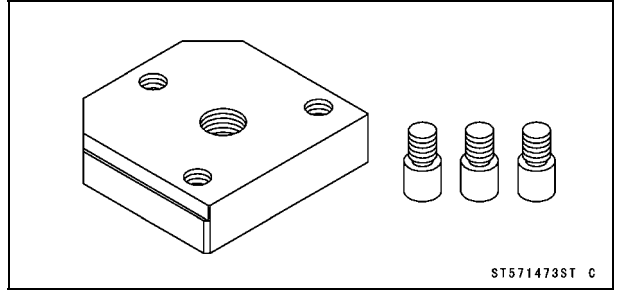

ST571473ST C

**Drive Pulley Wrench:**  
57001-1474

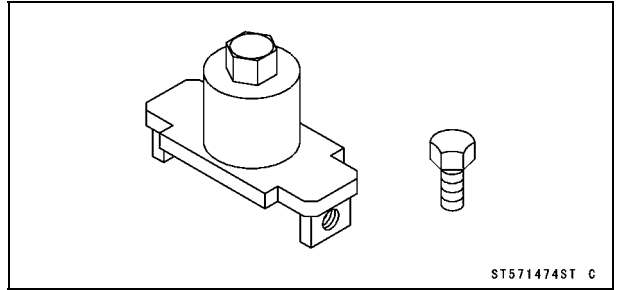

ST571474ST C

**Spring Holder Set:**  
57001-1483

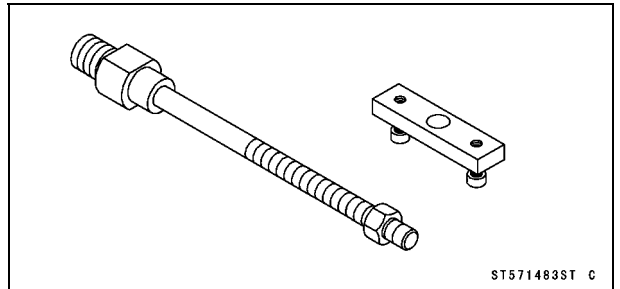

ST571483ST C

**Drive Pulley Measurement Tool:**  
57001-1498

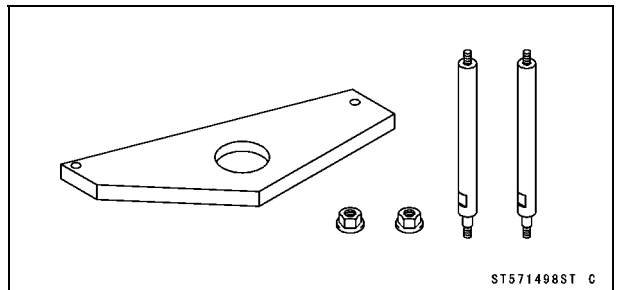

ST571498ST C

**Actuator Lever Measurement Tool:**  
57001-1499

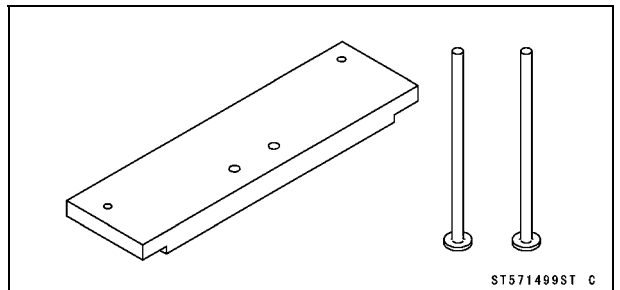

ST571499ST C

# 6-8 CONVERTER SYSTEM

## Special Tools

Drive Pulley Holder:

57001-1520

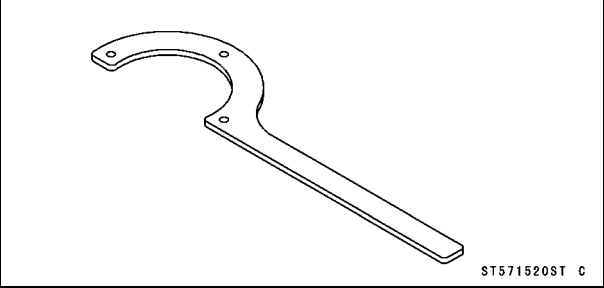



Torque Converter

**⚠ WARNING**

Excessive imbalance or operating rpm could cause torque converter pulley failure resulting in severe injury or death. The pulleys of the belt drive torque converter are precision balanced components designed to operate within certain rpm limits. Disassembly/assembly and servicing procedures of the pulley assemblies must be followed closely. Modifications to the engine or pulleys that increase rpm may cause failure.

**CAUTION**

Do not turn the ignition switch OFF position from ON position, while the torque converter cover is removed.  
If it is done, the learning control of Kawasaki Engine Brake Control system works and the engine brake actuator works an error operation.

**NOTE**

○If the drive belt failure detection system is activated by abnormal belt, the drive belt failure detection switch is damaged. Make sure to replace the torque converter cover (see Torque Converter Cover Removal/Installation).

*Torque Converter Cover Removal*

- Confirm that the ignition switch is in OFF position.
- Remove:
  - Right Side Cover (see Frame chapter)
  - Clamp Screws [A] and Clamps
  - Rubber Air Duct [B]
  
- Remove:
  - Actuator Lead Connector and Drive Belt Failure Detection Switch Lead Connector [A]
  - Torque Converter Cover Bolts [B]
  - Torque Converter Cover [C]

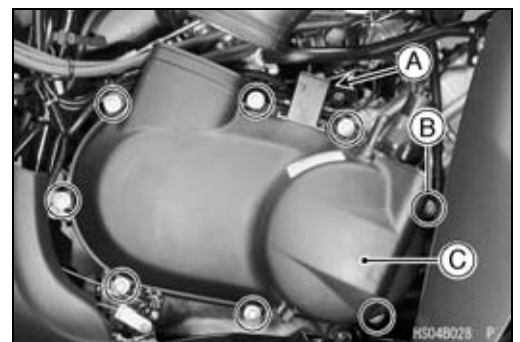
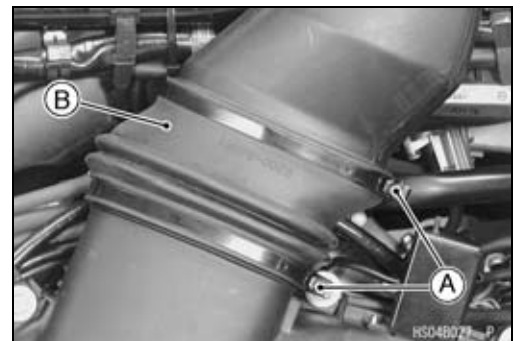

## 6-10 CONVERTER SYSTEM

### Torque Converter

#### Torque Converter Cover Installation

- Check the actuator lever assembly installation length (see Torque Converter Cover Assembly).
- Fit the trim seal into the converter cover.
- Set the trim seal juncture in the area [A] when insert the trim seal in the cover.  
[B] 10 mm (0.39 in.)

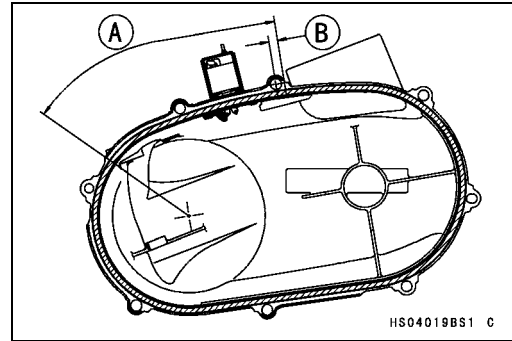

- Check:  
Drive Belt Failure Detection Switch (see Switch Inspection section in Electric System chapter)
- Set [A] the switch lever [B] to the ON mark side [C].  
Converter Cover [D]  
Front [E]

#### NOTE

- The failure detection system is activated when the switch is in the ON position. This is the normal running mode. Engine rpm is limited when the switch is in the OFF position.

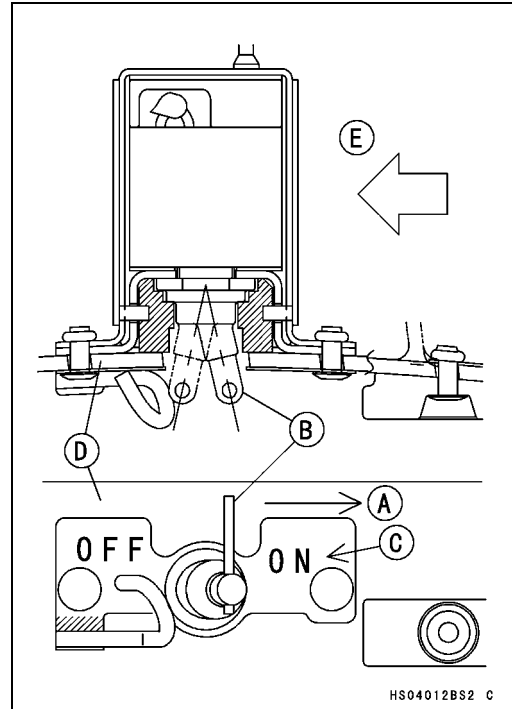

- Tighten (loosely):  
#3 Bolt  
#1 and #2 Bolts
- Press the cover downward and tighten the cover bolts following the tightening sequence as shown.

**Torque - Converter Cover Bolts: 8.8 N·m (0.90 kgf·m, 78 in·lb)**

[A] Clamp

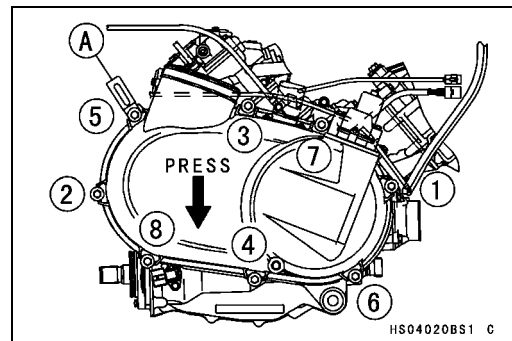

#### Torque Converter Cover Disassembly

- Remove:  
Torque Converter Cover (see Torque Converter Cover Removal)  
Engine Brake Actuator (see Electrical System chapter)  
Circlip [A]  
Spring [B]  
Actuator Lever Assembly [C]

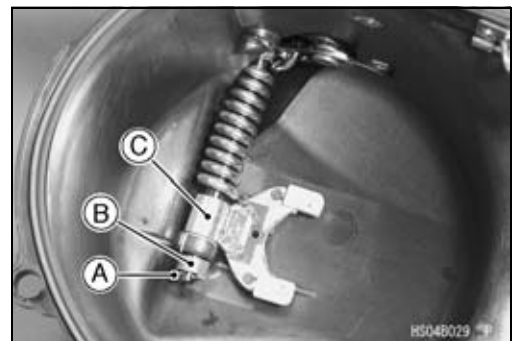

## Torque Converter

### Actuator Lever (Engine Brake Control Lever) Assembly Inspection

- Refer to the Actuator Lever (Engine Brake Control Lever) Assembly Inspection in the Periodic Maintenance chapter.

### Torque Converter Cover Assembly

- Install:
  - New Circlip
  - Spring
  - Actuator Lever Assembly
  - Engine Brake Actuator (see Electrical System chapter)
- Measure the installation length [A] of the actuator lever assembly between the cover end [B] and resin tips [C] on the actuator lever assembly as follows:

#### Actuator Lever Assembly Installation Length

**Standard:** 149.33 ~ 150.47 mm (5.879 ~ 5.924 in.)

- Remove the trim seal.
- Install the actuator lever measurement tool (plate [A] and rods [B]) on the torque converter cover [C] and tighten the two cover bolts.

**Special Tool - Actuator Lever Measurement Tool: 57001-1499**

- Set the rod ends on the resin tips [D].
- Measure the recess length [E] between the plate and rods with Vernier calipers [F] or depth gauge.

#### Measurement Length [E]

**Standard:** 1.33 ~ 2.47 mm (0.052 ~ 0.097 in.)

- ★ If the measurement is less than 1.33 mm (0.052 in.), use the actuator lever assembly (13236-0046) of yellow paint.
- ★ If the measurement is more than 2.47 mm (0.097 in.), use the actuator lever assembly (13236-0047) of green paint.
- ★ If the length is not within the specified length after the actuator lever assembly is replaced, replace the torque converter cover, and install the actuator lever assembly (13236-0048).

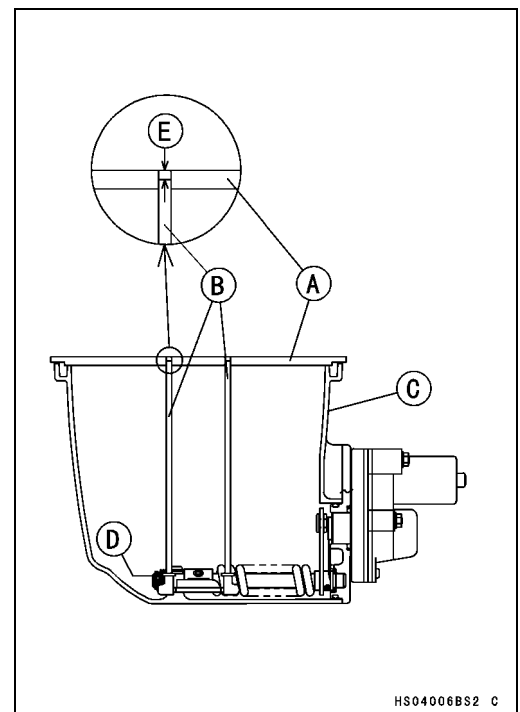
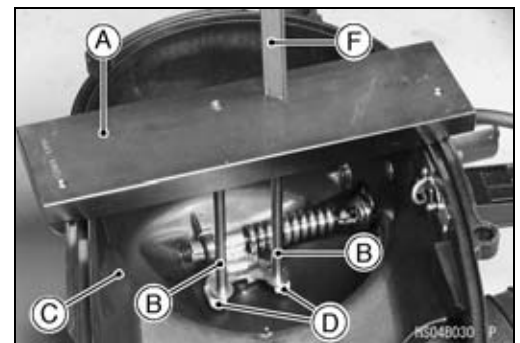
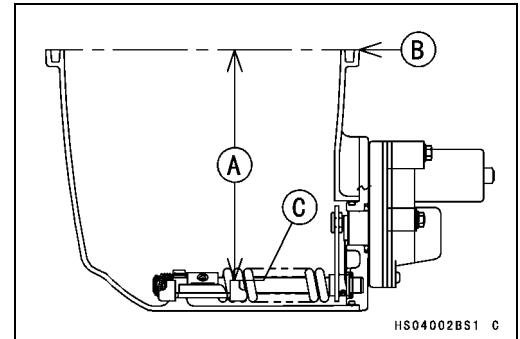

# 6-12 CONVERTER SYSTEM

## Torque Converter

### Actuator Lever Assemblies

Part Number	Paint Color [A]	Length [B]
13236-0046	Yellow	0.4 ±0.1 mm (0.016 ±0.004 in.)
13236-0048	None	1.0 ±0.1 mm (0.039 ±0.004 in.)
13236-0047	Green	1.6 ±0.1 mm (0.063 ±0.004 in.)

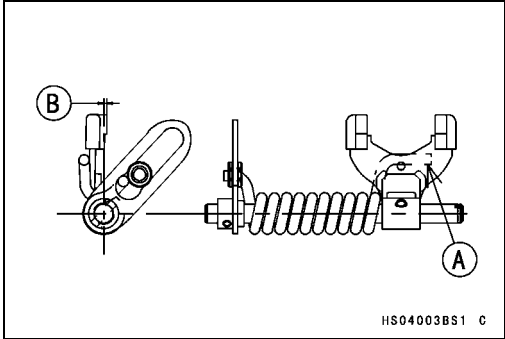

## Drive Belt

### Drive Belt Removal

- Remove the drive pulley [A] (see Drive Pulley Removal).

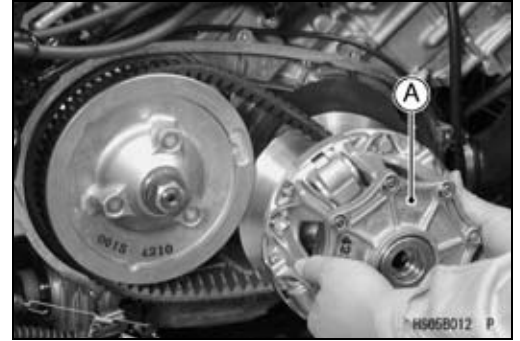

### NOTE

○ Before removing, observe the direction the belt's printed information [A] (such as manufacturer's name) is facing so that it may be reinstalled on the pulleys to rotate in the same direction as originally installed.

- Lift the drive belt [B] off the driven pulley [C].

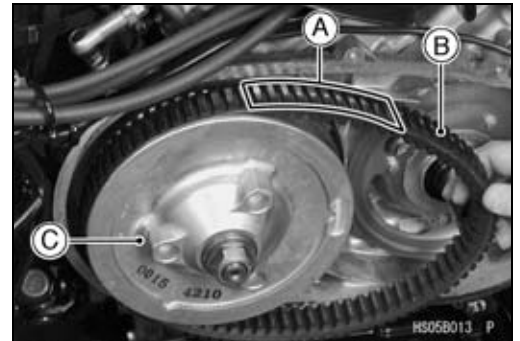

### Drive Belt Installation

### NOTE

○ Be sure the printed information faces the same direction so the belt rotates in the same direction as originally installed. When installing a new belt, install it so the printed information [A] can be read from beside the vehicle.

- Installation is basically the reverse of removal.
- Loop the belt [B] over the driven pulley [C].
- Install the drive pulley (see Drive Pulley Installation).
- Put the transmission in neutral, and rotate the driven pulley to allow the belt to return to the top [A] of the sheaves, before measuring belt deflection.

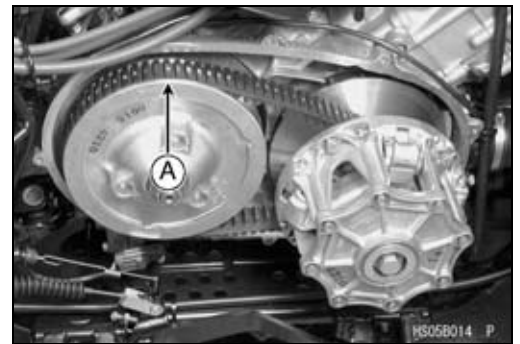
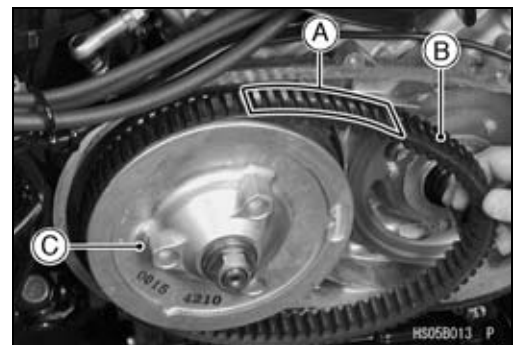

### Drive Belt Deflection Inspection

- Refer to the Drive Belt Deflection Inspection in the Periodic Maintenance chapter.

### Drive Belt Deflection Adjustment

- Refer to the Drive Belt Deflection Adjustment in the Periodic Maintenance chapter.

### Drive Belt Inspection

- Refer to the Drive Belt Inspection in the Periodic Maintenance chapter.

## 6-14 CONVERTER SYSTEM

### Drive Pulley

#### Drive Pulley Removal

- Remove the torque converter cover (see Torque Converter Cover Removal).
- Remove the three cover bolts [A] and install the drive pulley holder [B].

**Special Tool - Drive Pulley Holder: 57001-1520**

- Tighten the three cover bolts:  
**Torque - Drive Pulley Cover Bolts: 13 N·m (1.3 kgf·m, 113 in·lb)**
- Loosen the drive pulley bolt [C] (left-hand threads), holding the drive pulley with the drive pulley holder.

#### NOTE

○The drive pulley bolt has left-hand threads. Turn the wrench clockwise for loosening.

- Remove the drive pulley bolt, two washers, and the stepped washer, but do not remove the drive pulley holder yet.
- Remove the drive pulley [A] from the crankshaft by screwing the drive pulley puller bolt [B] **clockwise**, while holding the drive pulley with the drive pulley holder [C].

**Special Tool - Drive Pulley Puller Bolt: 57001-1429**

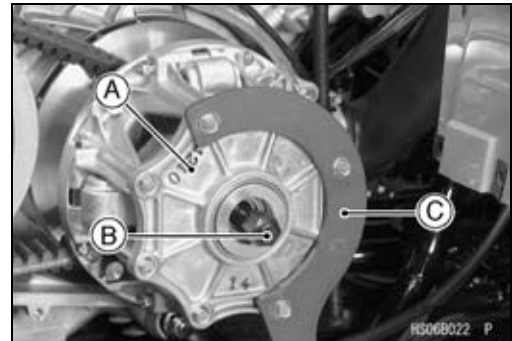
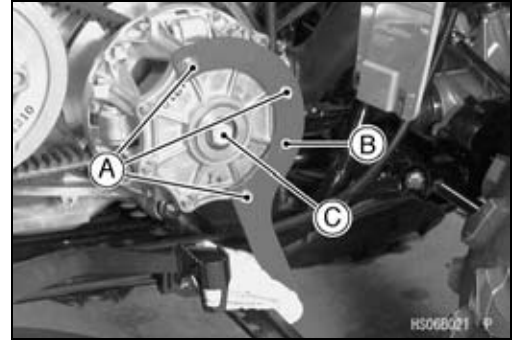

#### Drive Pulley Disassembly

- Hold the drive & driven pulley holder (57001-1473) [A] and the tapered guide of the holder (57001-1412) [B] in a vise so that the upper surface on the holder is 7 mm (0.28 in.) [C] above the vise.

**Special Tools - Drive & Driven Pulley Holder: 57001-1473**

**Drive & Driven Pulley Holder: 57001-1412**

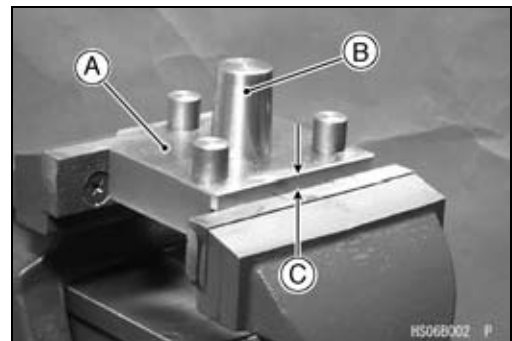

- Set the pulley onto the pulley holder.
- Remove:  
Drive Pulley Cover Bolts [A]  
Drive Pulley Cover [B]

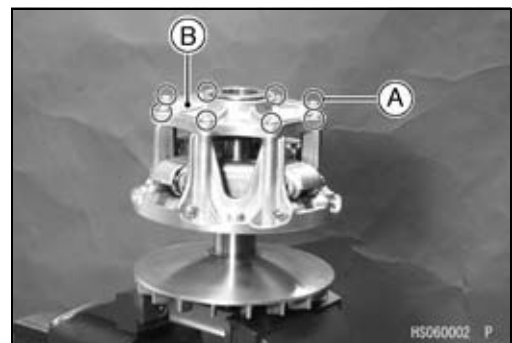

## Drive Pulley

- Remove:  
Spring [A]  
Spacer

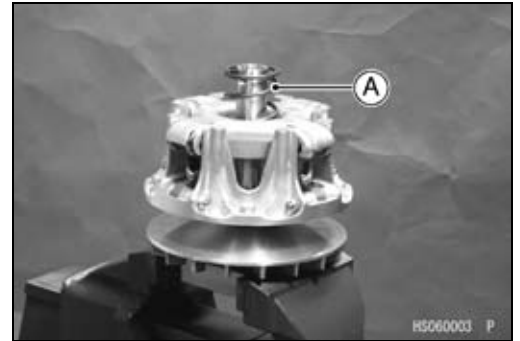

- Put the drive pulley wrench [A] on the spider [B] and tighten the bolt [C].

**Special Tool - Drive Pulley Wrench: 57001-1474**

- Turn the wrench clockwise and remove the spider with the movable sheave.

### NOTE

○The spider has left-hand threads. Turn the wrench clockwise for loosening.

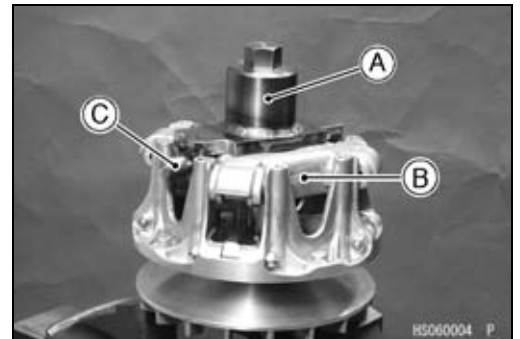

- Remove:  
Spider [A]  
Shoes [B]  
Nuts [C]  
Ramp Weight Pin [D]  
Ramp Weight [E]  
Movable Sheave [F]  
Fixed Sheave [G]

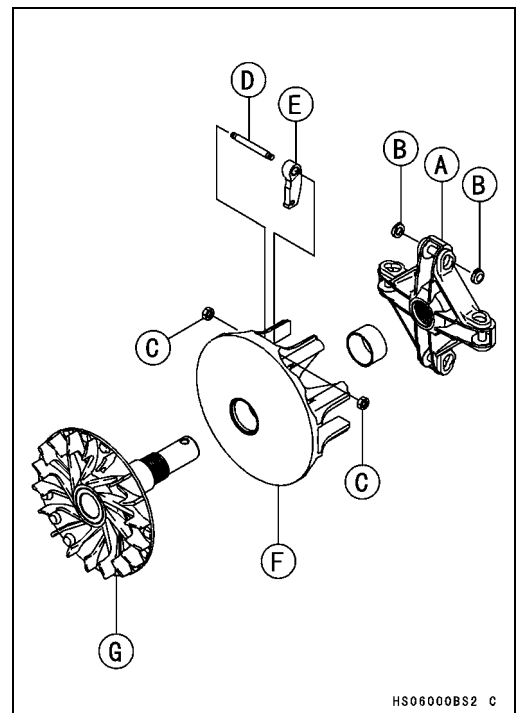

### Drive Pulley Inspection

- ★If the sheave surfaces [A] appear damaged, replace the sheaves.



## 6-16 CONVERTER SYSTEM

### Drive Pulley

- ★ If the cover bushing is damaged or worn, replace the drive pulley cover.

#### Cover Bushing Inside Diameter [A]

- Standard: 27.985 ~ 28.085 mm (1.1018 ~ 1.1057 in.)
- Service Limit: 28.12 mm (1.107 in.)

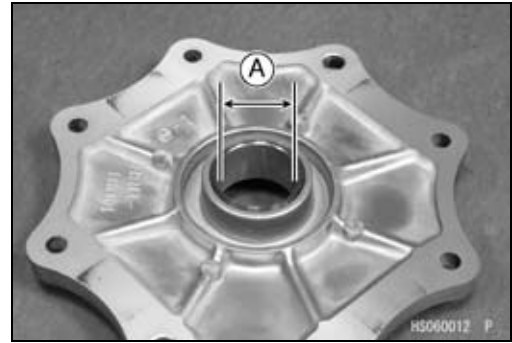

- ★ If the sheave bushing is damaged or worn, replace it.

#### Sheave Bushing Inside Diameter [A]

- Standard: 37.985 ~ 38.085 mm (1.4955 ~ 1.4994 in.)
- Service Limit: 38.12 mm (1.501 in.)

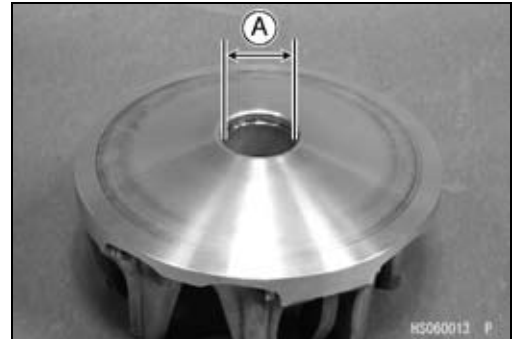

- ★ If the spider shoes [A] are damaged, replace them.
- Check the spider shoe side clearance (see Spider Shoe Side Clearance Inspection).

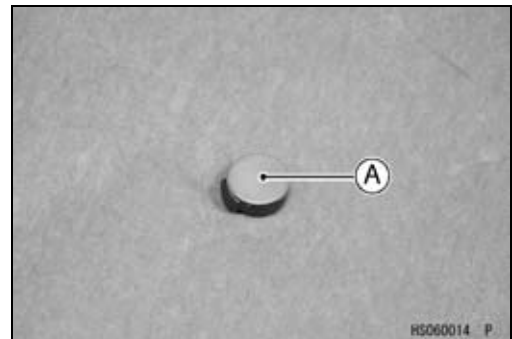

- ★ If the ramp weights [A] in the movable sheave are damaged or worn, replace them.
- ★ If the pins [B] are damaged or worn, replace them.

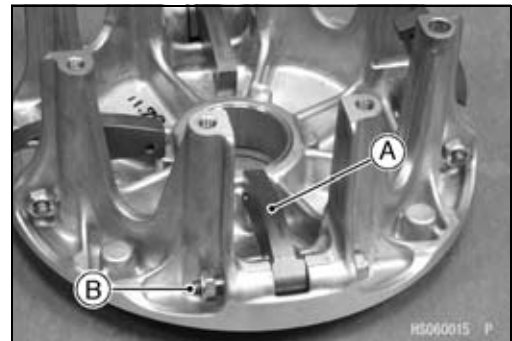

- ★ If the rollers [A] are damaged or worn, replace the spider [B].
- ★ If the washers [C] are damaged or worn, replace the spider.

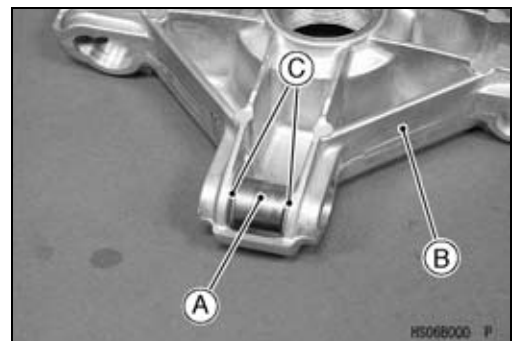



**Drive Pulley**

★If the spring is worn or damaged, replace the spring.

**Spring Free Length [A]**

Standard: 60.4 mm (2.38 in.)

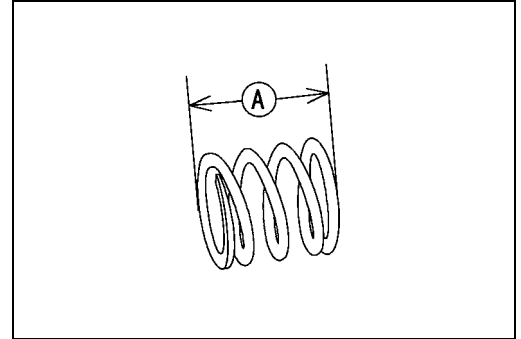

**Spider Shoe Side Clearance Adjustment**

- Remove:
  - Drive Pulley (see Drive Pulley Removal)
  - Drive Pulley Cover and Spring (see Drive Pulley Disassembly)
- Temporarily install the following parts on the movable sheave.
  - Dowel Pins (2)
  - Drive Pulley Cover
  - Two Bolts (at dowel pins)
- Do not install the spring.

- Turn the movable sheave counterclockwise.
- Measure the resulting clearance [A] between the shoe [B] and the post [C] on the movable sheave at two positions as shown.
  - [D] Arrow Mark

**Shoe Side Clearance**

Standard: up to 0.20 mm (0.008 in.), and there must be kept a clearance which the movable sheave [E] moves smoothly until it touches the fixed sheave [F] with its own weight.

★If the clearance is not the specified range, adjust it using the following shoes.

	Part Number	Thickness
Standard Shoe	49048-1090	7.5 mm (0.295 in.)
Adjustment Shoes	49048-1087	7.2 mm (0.283 in.)
	49048-1088	7.3 mm (0.287 in.)
	49048-1089	7.4 mm (0.291 in.)
	49048-1091	7.6 mm (0.299 in.)
	49048-1092	7.7 mm (0.303 in.)
	49048-1093	7.8 mm (0.307 in.)
	49048-1094	7.9 mm (0.311 in.)
	49048-1095	8.0 mm (0.315 in.)

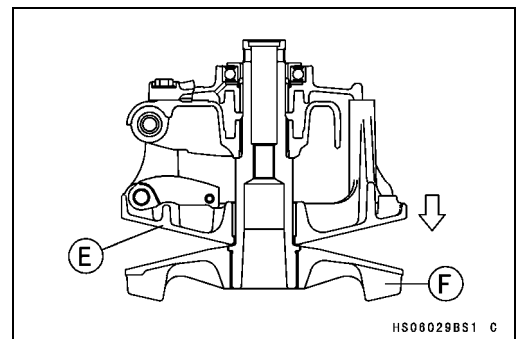
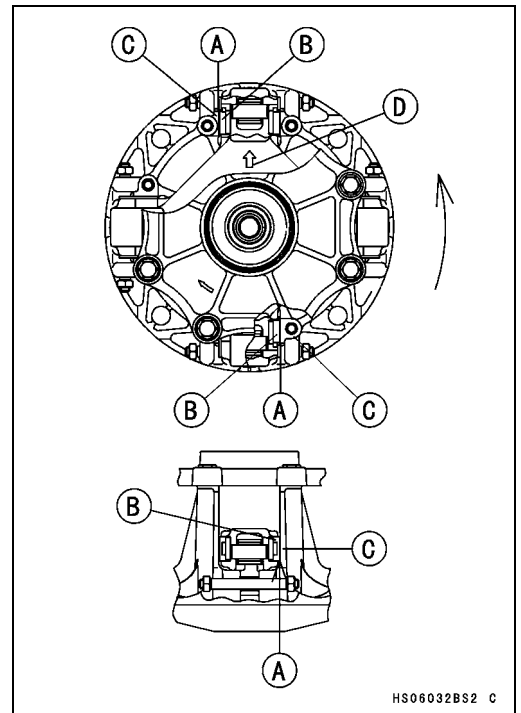

## 6-18 CONVERTER SYSTEM

### Drive Pulley

★If the clearance is not the specified range after the above shoes are replaced, use the spacer [A] (92026-0038) of the option part.

- [B] Shoe
- [C] Spider
- [D] Post
- [E] Clearance

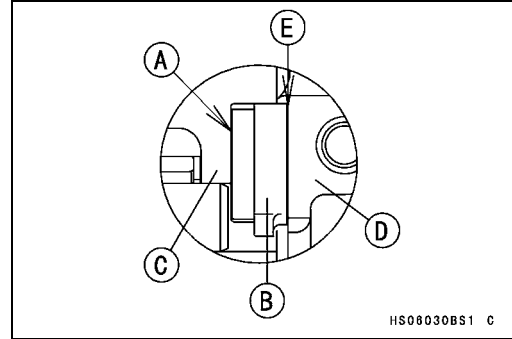

#### Drive Pulley Assembly

- Install the ramp weight [A] as shown.
- Tighten:
  - Torque - Ramp Weight Nuts [B]: 6.9 N·m (0.70 kgf·m, 61 in·lb)**
- Check that the ramp weights swing smoothly.



- Hold the fixed sheave [A] with the drive pulley holder [B] in a vise.

**Special Tool - Drive & Driven Pulley Holder: 57001-1473**

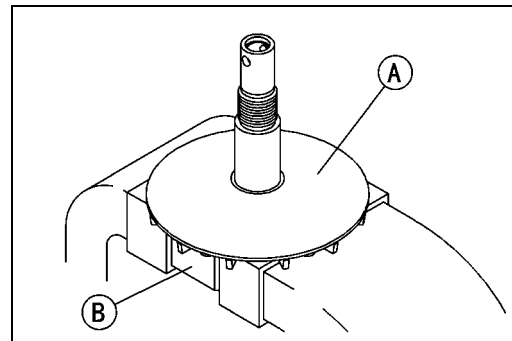

- Clean the threads of the fixed sheave and spider.
- Install:
  - Movable Sheave
  - Spider [A] and Shoes [B]
- Align the arrow [C] on the spider with the arrow [D] on the movable sheave.
- Insert the shoes so that the rubber side (black, small diameter) faces inward.

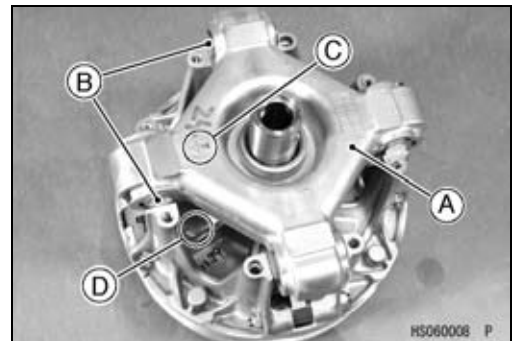

- Put the drive pulley wrench [A] on the spider [B] and tighten the bolt [C].

**Special Tool - Drive Pulley Wrench: 57001-1474**

- Turn the wrench counterclockwise for tightening.
  - Torque - Spider (left-hand threads): 275 N·m (28 kgf·m, 203 ft·lb)**

- Remove the drive pulley wrench.

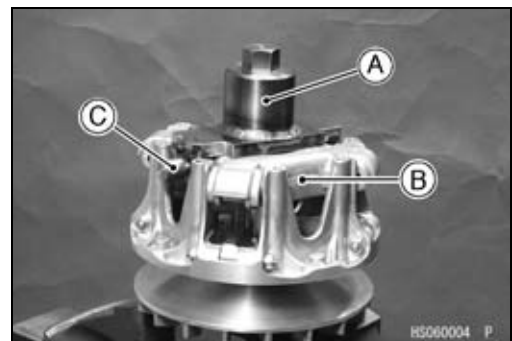

## Drive Pulley

- Install the spacer.
- Put the spring [A] in the groove of the spider.
- Align the arrows [B] on the drive pulley cover and spider.
- Install:
  - Dowel Pins [C]
  - Drive Pulley Cover
- Tighten:
  - **Torque - Drive Pulley Cover Bolts: 13 N·m (1.3 kgf·m, 113 in·lb)**
- Clean the surface of the sheaves with an oil-less cleaning fluid.

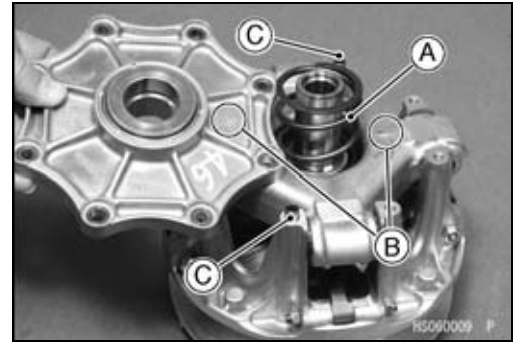

### Drive Pulley Installation

- Clean the following portions with an oil-less cleaning fluid such as trichloroethylene or acetone.
  - Fixed Sheave Tapered Portion [A]
  - Crankshaft Tapered Portion [B]

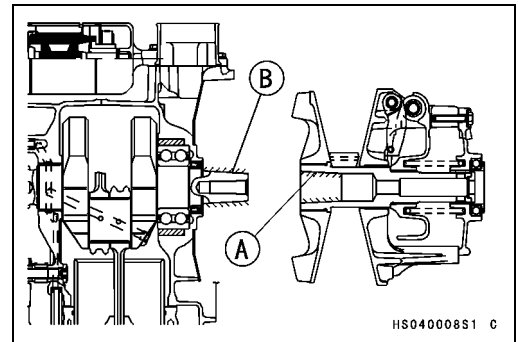

**⚠ WARNING**

**These cleaning fluids are usually highly flammable and harmful if breathed for prolonged periods. Be sure to heed the fluid manufacturer's warnings.**

- Install the drive pulley, stepped washer and two washers on the drive pulley bolt as shown.
  - Crankcase Side [A]
  - Stepped Washer [B]
  - Two Washers [C]
  - Bolt Head Side [D]

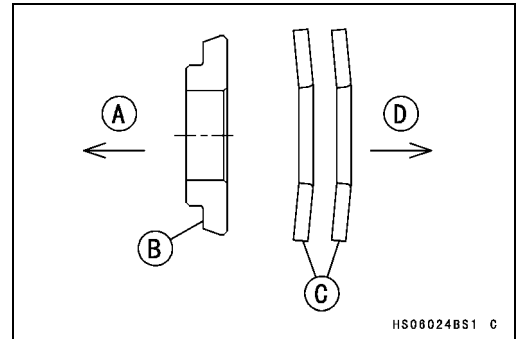

- Remove the three cover bolts [A] and install the drive pulley holder [B].
  - **Special Tool - Drive Pulley Holder: 57001-1520**
- Tighten:
  - **Torque - Drive Pulley Cover Bolts: 13 N·m (1.3 kgf·m, 113 in·lb)**
  - **Drive Pulley Bolt [C] (new, left-hand threads): 93 N·m (9.5 kgf·m, 69 ft·lb)**

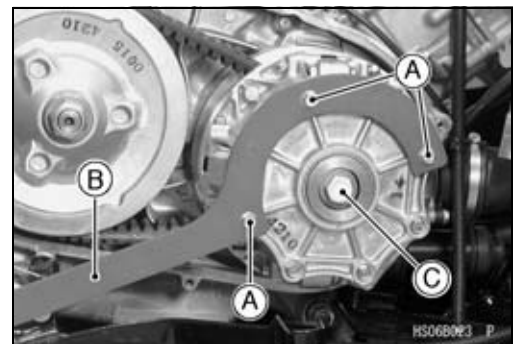

## 6-20 CONVERTER SYSTEM

### Drive Pulley

- Remove the drive pulley holder and install three drive pulley cover bolts to the specified torque.
- Adjust the installation length [A] of the drive pulley between the surface of the crankcase [B] and the collar [C] on the drive pulley as followings.

#### Drive Pulley Installation Length [A]

Standard: 149.85 ~ 150.95 mm (5.900 ~ 5.943 in.)

- Install the drive pulley measurement tool (legs [A] and plate [B]) on the crankcase [C].

**Special Tool - Drive Pulley Measurement Tool: 57001-1498**

- Measure the length [D] between the plate and collar [E] with vernier calipers [F] or a depth gauge.

#### Measurement Length [D]

Standard: 14.55 ~ 15.65 mm (0.573 ~ 0.616 in.)

- ★ If the measurement is not within the specified range, adjust it according to following table.

Status Quo		Replacement Part	
Measurement Length	Paint Color of Cover	Replace Part (Part Number)	Paint Color of Cover
less than 14.55 mm (0.573 in.)	Blue	Pulley Cover (14041-1161)	No Paint
	No Paint	Pulley Cover (14041-1159)	Red
	Red	Drive Pulley Assembly (49093-0014)	
more than 15.65 mm (0.616 in.)	Blue	Drive Pulley Assembly (49093-0014)	
	No Paint	Pulley Cover (14041-1160)	Blue
	Red	Pulley Cover (14041-1161)	No Paint

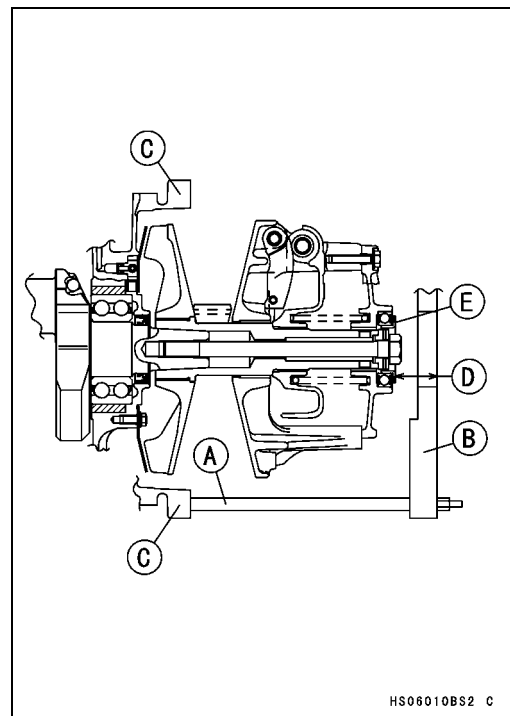
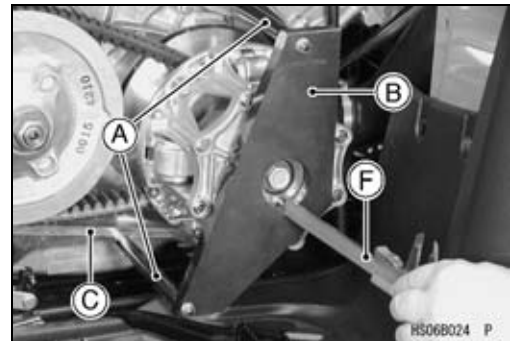
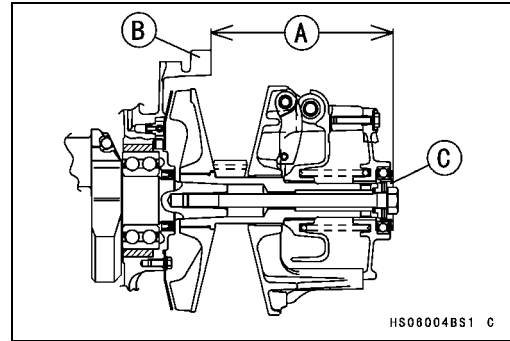

### Drive Pulley Covers

Part Number	Paint Color [A]	Length [B]
14041-1159	Red	24.0 mm (0.945 in.)
14041-1160	Blue	25.4 mm (1.000 in.)
14041-1161	No Paint	24.7 mm (0.972 in.)

- Measure the length again, after the drive pulley cover is replaces.

- ★ If the length is not within the specified length, replace the drive pulley assembly.

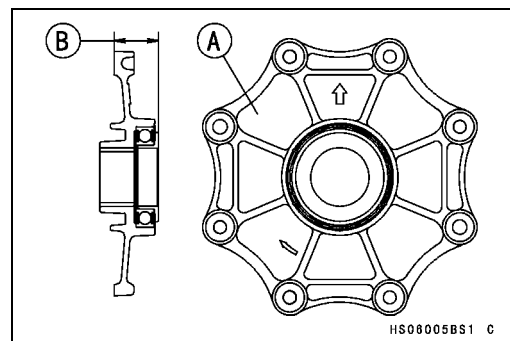

## Driven Pulley

### Driven Pulley Removal

- Remove:
  - Torque Converter Cover (see Torque Converter Cover Removal)
  - Drive Pulley (see Drive Pulley Removal)
  - Drive Belt (see Drive Belt Removal)
- Using the flywheel & pulley holder [A] and attachments [B], remove the driven pulley nut [C] and washers. (Nut has R/H threads.)

**Special Tools - Flywheel & Pulley Holder: 57001-1343**  
**Pulley Holder Attachment: 57001-1472**

- Remove:
  - Driven Pulley

### Driven Pulley Disassembly

- Hold the drive & driven pulley holder [A] in a vise.
  - Special Tool - Drive & Driven Pulley Holder: 57001-1473**
- Screw the guide bar [B] into the holder.
  - Special Tool - Spring Holder Set: 57001-1483**
- Put the driven pulley [C] on the guide bar.
- Tighten the nut [D], and compress the spring with the spring holder [E].
  - Special Tool - Spring Holder Set: 57001-1483**
- Remove the circlip [A] with circlip pliers [B].
  - Special Tool - Circlip Pliers: 57001-154**
- Remove the nut and spring holder [C].

- Remove:
  - Spring Seats [A]
  - Spring [B]
  - Thrust Plate [C]

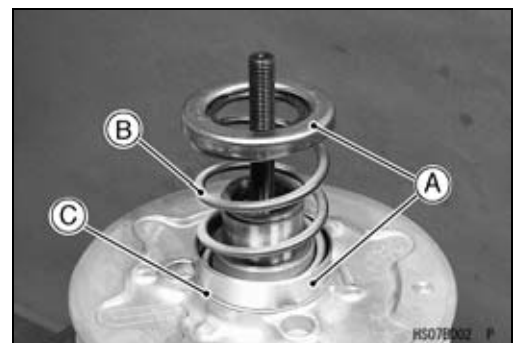
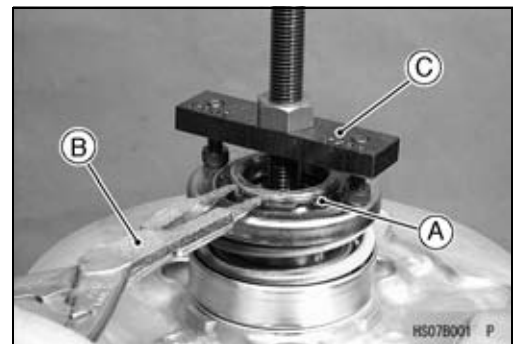
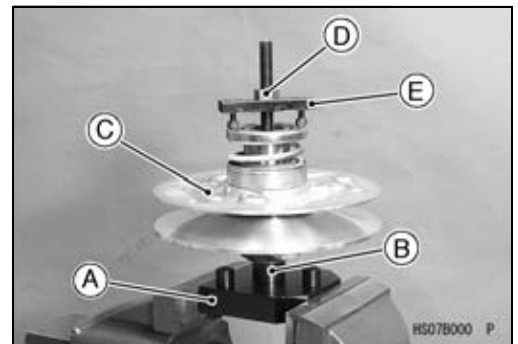
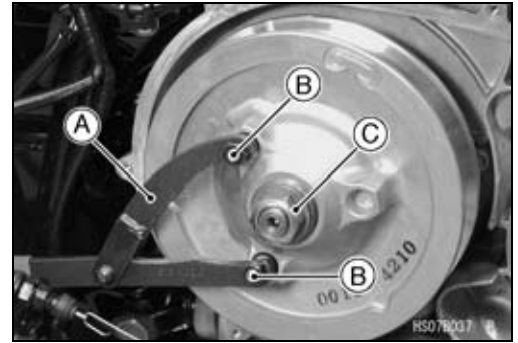

## 6-22 CONVERTER SYSTEM

### Driven Pulley

- Confirm the paint mark "0" [A] on the movable sheave [B] in alignment with the point [C] on the fixed sheave [D] for phase fit of the sheaves.

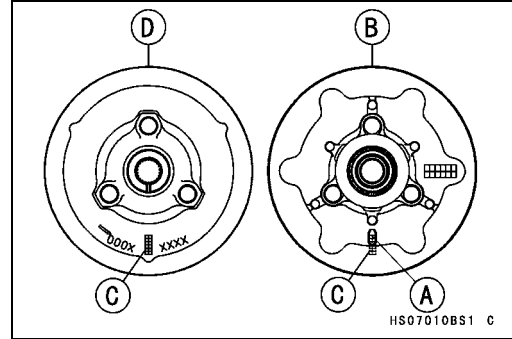

- Wipe off the molybdenum disulfide grease.
- Remove the four pins [A] with a thin standard tip screwdriver [B].
- Remove the movable sheave from the fixed sheave.

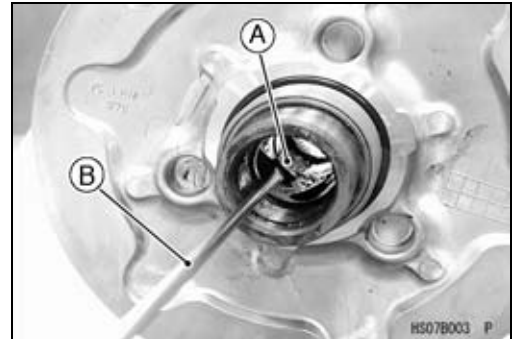

- Remove:  
Spacer(s) [A] (for Drive Belt Deflection Adjustment)



#### Driven Pulley Inspection

- ★ If the sheave surfaces [A] appear damaged, replace the sheaves.



- Replace the sheave with uneven wear on the belt contacting surfaces.

[A] Sheave Surface  
[B] Straight Edge

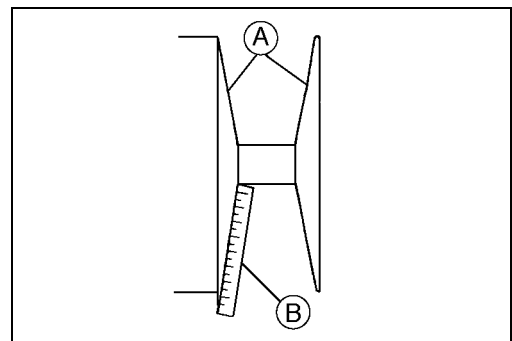

## Driven Pulley

- ★ If the sheave bushings [A] are damaged or worn, replace the movable sheave.

### Sheave Bushing Inside Diameter

**Standard:** 40.000 ~ 40.039 mm (1.5748 ~ 1.5763 in.)

**Service Limit:** 40.07 mm (1.578 in.)

- Inspect seals for damage.
- ★ If seals are damaged, replace the movable sheave.

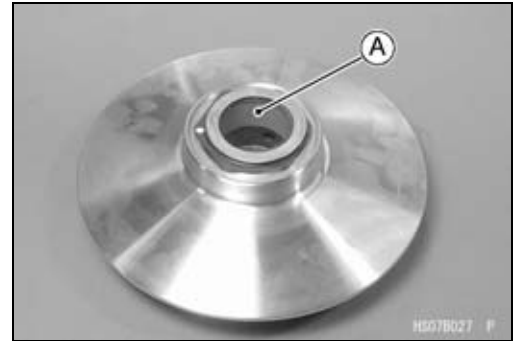

- ★ If the splines [A] are damaged or worn, replace the fixed sheave.



- ★ If the spring is damaged or worn, replace the spring.

### Spring Free Length [A]

**Standard:** 99.5 mm (3.92 in.)

- ★ If the spring coils are distorted, replace the spring.

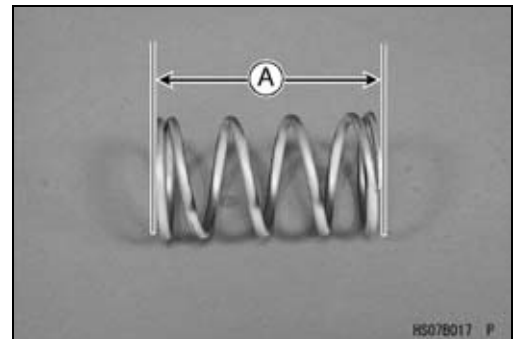

### Driven Pulley Assembly

- Clean off any grease or dirt on the movable and fixed sheaves, and dry them with a clean cloth.
- Install:
  - Spacers [A] (for Drive Belt Deflection Adjustment, see Periodic Maintenance chapter)

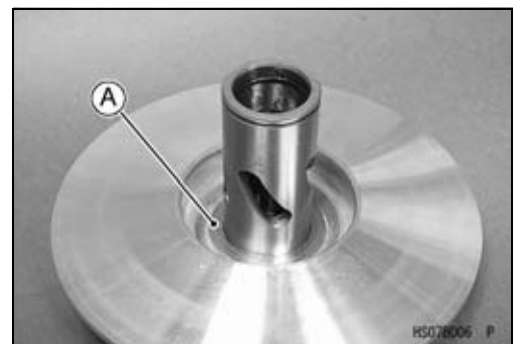

- Apply grease to the oil seal lips [A].
- Press the oil seals [B] in the movable sheave assembly so that the oil seal surface is flush [C] with the sleeve end.
- Apply [D] grease WR500-No.2 (KYODO YUSHI), POWER LITE WR #2 (KYODO YUSHI), or SERAN-HV (TOTAL FINA) to the inner surfaces of the bushings.

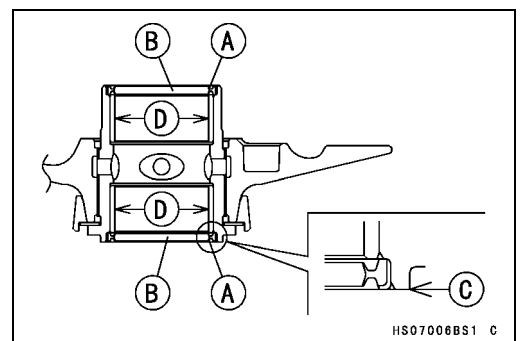

## 6-24 CONVERTER SYSTEM

### Driven Pulley

- Align the paint mark "0" [A] on the movable sheave [B] with the point [C] on the fixed sheave [D] for phase fit of the sheaves.

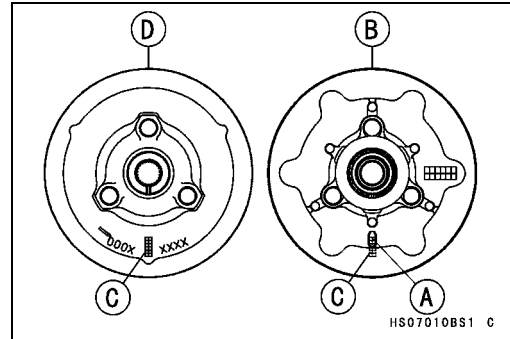

- In that case the opening [A] and hole [B] will be matched easily.

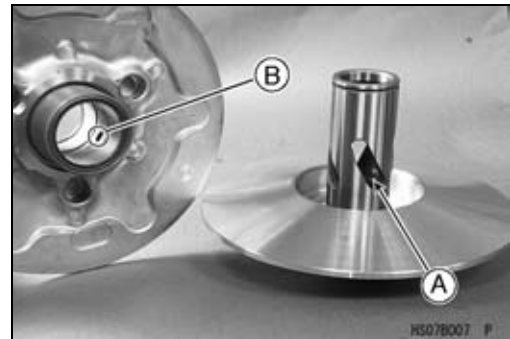

- Apply grease WR500-No.2 (KYODO YUSHI), POWER LITE WR #2 (KYODO YUSHI), or SERAN-HV (TOTAL FINA) to the seating surface [A] of the pins, and insert them into the holes in the movable sheave.

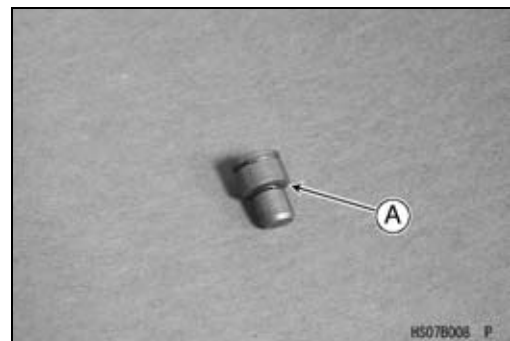

- Draw the movable sheave onto the fixed sheave, and apply grease of 1 g (0.035 oz) to all openings [A].

**Grease - WR500-No.2 (KYODO YUSHI) or  
POWER LITE WR #2 (KYODO YUSHI) or  
SERAN-HV (TOTAL FINA)**

#### NOTE

○ Do not heap up the grease out of the openings.



- Check that the O-rings [A] are in good condition.
- ★ If any of the O-rings are damaged, replace them.
- Apply grease to the O-rings.

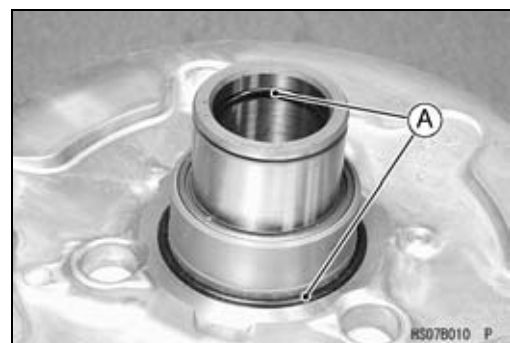



## Driven Pulley

- Hold the drive & driven pulley holder in a vise.
  - **Special Tool - Drive & Driven Pulley Holder: 57001-1473**
- Screw the guide bar into the holder.
  - **Special Tool - Spring Holder Set: 57001-1483**
- Put the driven pulley [A] onto the guide bar.
- Put the thrust plate [B] so that the alloy side (gray) faces the movable sheave.
- Install:
  - Spring Seat [C]: 18.5 mm (0.728 in.)
  - Spring [D]
  - Spring Seat [E]: 9.3 mm (0.366 in.)
  - Circlip [F]
- Tighten nut [A], and compress the spring with the spring holder [B].
  - **Special Tool - Spring Holder Set: 57001-1483**
- Install a new circlip [C] with circlip pliers [D].
  - **Special Tool - Circlip Pliers: 57001-154**
- Remove the driven pulley from the spring holder set.
- Clean the surface of the sheaves with an oil-less cleaning fluid.

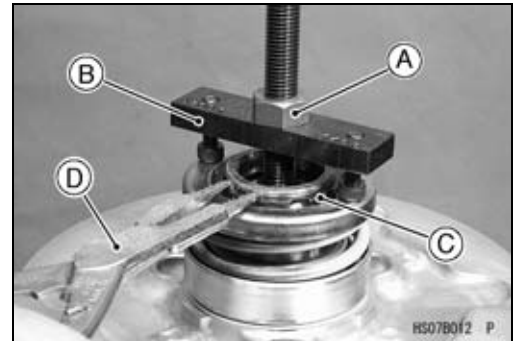
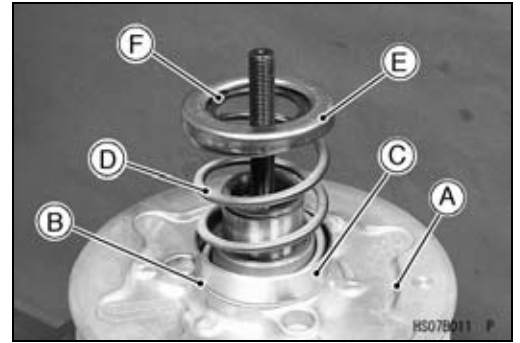

### Driven Pulley Installation

- Clean the transmission driven shaft [A].
- Install:
  - Driven Pulley

#### NOTE

○When engaging the spline on the driven pulley with the spline [B] on the shaft, do not damage the pulley's spline. If any damage occurs, remove it with a file.

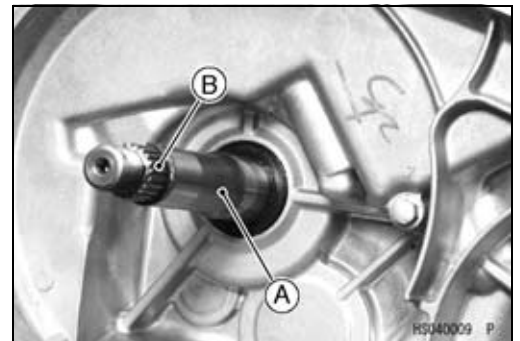

- Clean the threads of the driven shaft and driven pulley ends to open the air vent passage. Wipe off any extra grease.
- Wipe off any protruding grease [A].



## 6-26 CONVERTER SYSTEM

### Driven Pulley

- Install two washers [A] on the shaft as shown.  
Crankcase Side [B]  
Bolt Head Side [C]

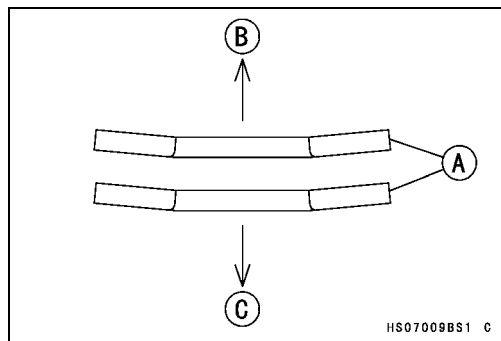

- Using a flywheel & pulley holder [A] and attachments [B], tighten the driven pulley nut [C].

**Special Tools - Flywheel & Pulley Holder: 57001-1343**

**Pulley Holder Attachment: 57001-1472**

**Torque - Driven Pulley Nut: 93 N·m (9.5 kgf·m, 69 ft·lb)**

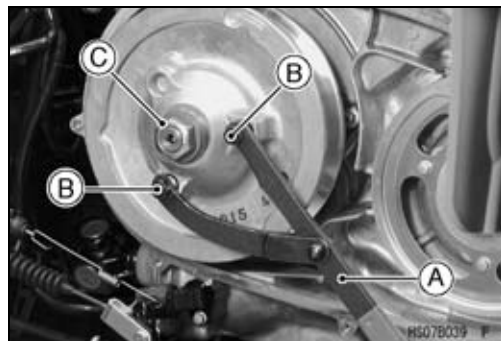

**High Altitude Setting Information**

*Specifications*

Altitude m (ft)	Drive Pulley		Carburetor
	Ramp Weights	Spring Spacer (qty)	Main Jet
0 ~ 1 200 (0 ~ 3 900)	P/No. 39152-1081 (STD, C)	P/No. 92026-1603 (1) t = 1 mm (0.04 in.)	Front: #152 (P/No. 92063-1331) (STD) Rear: #158 (P/No. 92063-1344) (STD)
1 200 ~ 2 500 (3 900 ~ 8 200)	P/No. 39152-1081 (STD, C)	P/No. 92026-1603 (1) t = 1 mm (0.04 in.)	Front: #145 (P/No. 92063-1017) Rear: #152 (P/No. 92063-1331)
2 500 ~ 3 500 (8 200 ~ 11 500)	P/No. 39152-1088 (C1)	P/No. 92026-1603 (2) t = 1 mm (0.04 in.)	Front: #142 (P/No. 92063-1016) Rear: #148 (P/No. 92063-1324)
3 500 ~ 4 500 (11 500 ~ 14 800)	P/No. 39152-1088 (C1)	P/No. 92026-1603 (2) t = 1 mm (0.04 in.)	Front: #135 (P/No. 92063-1014) Rear: #140 (P/No. 92063-1013)

C, C1: Identification Marks

qty: quantity

- Refer to the Drive Pulley section in this chapter and Carburetor section in the Fuel System chapter for the parts replacement.